

WAR DEPARTMENT FIELD MANUAL

FM 21-15

*This manual, together with FM 20-15, 24 February 1945, supersedes FM 21-15, "Equipment, Clothing, and Tent Pitching," 1 October 1940, including C 1, 23 August 1941; C 2, 23 April 1942; C 3, 27 May 1942; C 4, 2 August 1942; C 5, 5 December 1942; C 6, 30 March 1943; and TB QM 20, 15 July 1944.*

---

INDIVIDUAL  
CLOTHING AND EQUIPMENT

---



WAR DEPARTMENT • APRIL 1945

---

United States Government Printing Office  
Washington: 1945

WAR DEPARTMENT

Washington 25, D.C., 30 April 1945

FM 21-15, Individual Clothing and Equipment, is published for the information and guidance of all concerned.

[AG 300.7 (27 Sep 44)]

BY ORDER OF THE SECRETARY OF WAR:

OFFICIAL:

J. A. ULIO  
*Major General*  
*The Adjutant General*

G. C. MARSHALL  
*Chief of Staff*

DISTRIBUTION:

C of S(1); AAF(10); AGF(40); ASF(2); T of Opns (5); Arm & Sv Bd(2); Def Comd(5); S Div ASF(2); Tech Sv(2) except 10(250); SvC(5); PC&S(2); PE (10); Dep(2); Gen & Sp Sv Sch(50); USMA(50); ROTC(5); Tng C(100) except 5, 10(500); RC(5); Reclass C(5); A(10); CHQ(5); D(5); B(5); R(5); Bn(5); C(15); AF(10); W(5); G(5); S(15).

Refer to FM 21-6 for explanation of distribution formula.

## FOREWORD

---

This manual sets forth the broad principles governing the care and maintenance of those items of clothing and individual equipment for which the soldier is responsible. It prescribes the method of pitching shelter tents and the use of other bivouac equipment, the method of assembling and packing authorized field packs, and the procedure governing the display of basic equipment for formal inspection.

The care of arms and technical equipment, the care of many specific items of clothing and equipment, and the pitching of other tents are prescribed in other Field Manuals, in Technical Manuals, and in other War Department publications. The articles constituting the uniform, the wearing of the uniform, and insignia and brassards are prescribed in Army Regulations.

# CONTENTS

---

## SECTION I. CARE OF CLOTHING AND INDIVIDUAL EQUIPMENT.

|   | <i>Paragraph</i> | <i>Page</i> |
|---|------------------|-------------|
| General .....                             | 1                | 1           |
| Responsibility .....                      | 2                | 1           |
| Care of clothing .....                    | 3                | 2           |
| Care of leather .....                     | 4                | 5           |
| Care of metal .....                       | 5                | 7           |
| Care of horse covers and saddle blankets. | 6                | 7           |
| Care of cinchas or girths .....           | 7                | 8           |
| Care of web equipment .....               | 8                | 8           |
| Care of canvas .....                      | 9                | 9           |
| Care of wood .....                        | 10               | 9           |
| Care of mess equipment .....              | 11               | 9           |
| Care of canteen .....                     | 12               | 10          |
| Care of knives .....                      | 13               | 10          |
| Care of miscellaneous equipment .....     | 14               | 10          |

## II. BIVOUAC EQUIPMENT.

|  |    |    |
|--|----|----|
| General .....  | 15 | 12 |
| Tent, shelter .....                                  | 16 | 12 |
| Bag, sleeping, wool, and case, water-repellent ..... | 17 | 18 |
| Bars, mosquito .....                                 | 18 | 19 |

## III. METHOD OF ASSEMBLING AND PACKING EQUIPMENT.

|                   |    |    |
|-------------------|----|----|
| General .....     | 19 | 20 |
| Bag, duffel ..... | 20 | 20 |

|   | <i>Paragraph</i> | <i>Page</i> |
|---|------------------|-------------|
| Assembling and attaching haversack, M-1928, and carrier, pack, M-1928, and accompanying equipment ..... | 21               | 21          |
| Assembling and attaching bag, canvas, field, od, M-1936, and accompanying equipment .....               | 22               | 41          |
| Assembling and attaching rucksack and accompanying equipment .....                                      | 23               | 46          |
| Assembling and attaching jungle pack..  | 24               | 46          |
| Assembling and attaching pack, field, and accompanying equipment .....                                  | 25               | 46          |
| Assembling and attaching pack, field, cargo and combat, accompanying equipment .....                    | 26               | 50          |
| Packboard .....   | 27               | 61          |
| Method of packing individual equipment on horse .....   | 28               | 74          |

**IV. DISPLAY OF BASIC EQUIPMENT FOR FORMAL INSPECTION.**

|   |    |    |
|---|----|----|
| Enlisted man with haversack and pack carrier, canvas field bag or rucksack, jungle pack, field pack, or cargo and combat field pack ..... | 29 | 79 |
| Mounted enlisted men or those similarly equipped .....  | 30 | 80 |
| Formal inspection in a barracks .....   | 31 | 83 |

|                    |  |           |
|--------------------|--|-----------|
| <b>INDEX .....</b> |  | <b>86</b> |
|--------------------|--|-----------|

## SECTION I

### CARE OF CLOTHING AND INDIVIDUAL EQUIPMENT

---

**1. GENERAL.** Upon enlistment or induction in the Army, enlisted personnel receive a prescribed initial issue of clothing and equipment. Other items are subsequently issued according to mounted or dismounted status, occupation, arm or service, and duty assignment. Specialized items have been designed to meet combat needs and climatic conditions. (See T/E 21 and AR 615-40.)

**2. RESPONSIBILITY.** Soldiers are responsible for the clothing and individual equipment issued to them, including proper care and maintenance. Articles that become excess because of changed status must be turned in. Responsibility is fixed in order that economy may be promoted. If, through carelessness, officers and enlisted personnel lose or damage clothing and equipment that are issued them, the cost of replacing or repairing the articles is charged to them. In the combat zone the availability of supplies is of primary importance to every fighting man. While the accountability of property may be suspended temporarily during combat, the responsibility for protection from loss or damage of all items

of equipment still continues, except in cases known to be beyond the control of the individual. It is the duty of every soldier to conserve clothing and equipment in order that items will be available and in serviceable condition when they are needed. If clothing has been improperly handled, the soldier may suffer because of his carelessness. A field jacket, M-1943, without buttons and waist drawstring will give inadequate protection in changeable weather. A torn sleeping bag provides inadequate warmth on cold nights. A rifle that has been neglected may not fire. Casualties have been increased because soldiers' essential equipment was not at hand and in good condition when it was needed.

**3. CARE OF CLOTHING. a. Repair.** Each soldier must make such minor repairs as mending rips and tears and sewing on buttons. The commanding officer will direct the sending to quartermaster repair shops of those items that cannot be repaired by individuals. A damaged garment should be repaired immediately or immediately turned in, for delay may render it irreparable.

**b. Protection against mildew and moths.** Clothing should be thoroughly brushed and dried before it is hung in barracks or packed away. Air spaces should be left between garments that are hung in barracks. At intervals garments should be taken out and aired, preferably in the sunshine. If mildew forms, clothing should be brushed thoroughly and then hung in the sun. Woolen garments should be dry-cleaned before they are stored.

**c. Cleaning.** (1) Each soldier must keep his clothing clean. A uniform that gets dirty and stays dirty wears out quickly because the dirt cuts the fibers of the cloth and collects and holds moisture. It is impossible to keep the uniform from getting dirty but it need not stay dirty. Brush and clean it, or have it cleaned, regularly.

(2) Remove all spots immediately. The longer they remain, the harder they are to get out. Do not have uniforms pressed unless all spots have been removed.

(a) *Gravy spots.* To remove meat juice or gravy, use cold water, then cleaning fluid, with a pad underneath the fabric. Don't rub woolens excessively. Rubbing damages the finish.

(b) *Fruit stains.* Stains from fresh fruits can be washed off cotton khakis with boiling or even warm water (if the stains are still moist). If the stains come from cooked fruit or berries, stretch the stained portion over a bowl and pour boiling water on it so that the water will strike the stain with some force.

(c) *Grease or oil spots.* Scrape off the top, then wash with mild soap and warm water.

**d. Pressing.** For any pressing job, moisture is always necessary. For woolens, use a damp cloth between the iron and the fabric. For cotton khakis, dampen the surface of the fabric and apply the iron directly. Be sure not to get the iron too hot.

**e. Protection of waterproofed and water-repellent clothing.** (1) *General.* After waterproof and water-repellent clothing has been worn in inclement weather, it should be thoroughly dried. To detect holes, hold waterproofed garments to the light and examine them. If defective, they should be turned in for repair. When water-repellent garments lose their water repellency, they should be turned in for treatment by a quartermaster laundry.

(2) *Care of raincoat and poncho.* (a) When packing the raincoat, be sure that the folds are smooth and even. If articles are left in the pockets, they will tear and rub the garment when it is carried in the pack and cause it to sag when it is hung in barracks or tents. To prevent rust, the raincoat should be hung on a wooden or cardboard hanger and never on a metal hanger.



(b) When these items become soiled, wipe them off with a clean cloth and then wash them with soap and water.

(c) Don't leave them exposed to the sun for long periods of time. Heat causes them to dry out and crack.

(d) Don't leave them near flames or artificial heat of any kind even for short periods.

(e) Don't let them get contaminated with oil, grease, acid, or insect repellent.

**f. Care of helmet.** The helmet is a very important item of clothing.

(1) *Don't use it as a seat*, as the chin strap loops may break off.

(2) *Don't use it as a shovel*. The paint will be rubbed off.

(3) *Don't cook in it*. It was not made for that purpose. It is made of steel that is especially treated to give maximum protection against bullet penetration. Heating may weaken it.

(4) *Be careful not to let it get scratched*. Every helmet is demagnetized so that out in the field the steel in the helmet won't interfere with the use of a compass. Any serious abrasion of the helmet surface may affect the compass.

(5) *Take care of liner*. If the helmet liner is put into the barrack or duffel bag, be sure to have it well protected with blankets or clothing. Pack something soft inside the liner as well as around it to keep it from getting cracked or broken. *Don't sit on the liner or use it for a pillow*.

**g. Care of socks.** Change socks often, every day if possible. Wash them regularly, because perspiration rots the fibers. For comfort and "wearability," be sure the socks fit. If they are too large, they will wrinkle inside the shoes, rub the feet, and cause blisters. If they are too small, they will soon wear out at the toes. Small socks are particularly bad for the individual in cold weather because they reduce circulation of blood and cause trench foot and frostbite.

**4. CARE OF LEATHER. a. General.** Because leather is one of the most important materials that goes into the making of clothing and equipment for the Army, its maintenance is of utmost importance. During time of war there is usually a critical shortage of the first grade material from which shoes, boots, and other leather articles issued to members of the Armed Forces must be made. Therefore, the soldier should give to his leather equipment such care as will prolong its usefulness.

**b. Cleaning and oiling agents.** Leather must be kept in good condition by use of cleaning and oiling agents. The use of bleaching agents, dyes, and other chemicals in an effort to restore or alter the original color of leather is prohibited.

**c. Boots and shoes. (1) Breaking-in.** Shoes must be broken in before they are used on long marches. Breaking-in is more easily accomplished if dubbing is applied frequently. During the first few days a new pair of shoes or boots should be worn for short periods of time. IF PRACTICABLE, A PAIR OF SHOES SHOULD NOT BE WORN ON 2 SUCCESSIVE DAYS.

**(2) Use of dubbing.** Dubbing must be applied once a week to the service shoes and combat boots of all troops operating in temperate climates and at least twice a week to the service shoes and combat boots of troops operating in wet or extremely dry climates. Dubbing makes shoes softer and more comfortable as well as water-resistant. This lubricant is more effective if it is frequently and liberally applied and if it is well rubbed into the leather. Shoes and boots need not be dried before applications are made. Shoes to which dubbing has been applied cannot be polished. Footwear should be inspected for dubbing rather than for high polish.

**(3) Cleaning.** Dirt or mud must be scraped off with a dull instrument that will not cut the leather. Then boots or

shoes may be washed with soap and water. Drying by direct exposure to hot sun, fire, or strong heat is prohibited because it is injurious to the leather.

(4) *Repair*. Get repairs early. Don't continue to wear shoes or boots until the damage becomes serious. Be sure they are turned in for repair when any of the following conditions are noted:

(a) Rips in any upper leather stitching or sole stitching.

(b) Shanks (narrowest part of the sole) damaged or badly worn. Any part of the upper or sole pulled loose from the welt.

(c) Cracked soles.

(d) First evidence of a hole in the outer sole, or when the outer sole is too thin and it is evident that it will soon be worn through.

(e) Heels missing or worn down more than  $\frac{1}{4}$  inch.

(f) Any other type of wear which will interfere with comfort or economical repairability.

**d. Harness and saddlery.** (1) *General*. Harness and saddlery must have daily care in order to be kept in good condition.

(2) *Cleaning*. Separate all parts, unbuckle straps, and remove parts that are detachable. With a damp (not wet) sponge, remove all surface dust, mud, or other foreign substances. Do not immerse in water. Rinse the sponge and, using as little water as possible, make a heavy lather by rubbing the sponge vigorously on saddle soap. Clean each piece of equipment thoroughly. Straps should be drawn through the lathered sponge. After the leather has become partly dry, rub it vigorously with a soft cloth. If it seems necessary to oil the leather, apply neat's-foot oil sparingly on the flesh or unfinished side of the leather, using light quick strokes in order to obtain even distribution. Excessive oil is injurious to leather equipment.

**5. CARE OF METAL.** **a. Metal parts.** When not in use, bits, curb chains, belt buckles, and all other metal parts that are issued unpainted must be oiled lightly at intervals. When in use, they must be kept clean and free from rust. The removal of paint from metal parts is prohibited unless the responsible officer authorizes such for the purpose of renovation.

**b. Restoring finish.** To restore dark finish on brass, dip the parts in a solution of ammonium hydroxide that has been saturated with copper carbonate. Saddle fittings may be painted with this solution by the use of a small brush. Care must be taken to prevent the solution from coming in contact with the leather.

**c. Insignia and buttons.** Insignia and buttons that have a gold finish should be cleaned with ammonia and water. Because an abrasive will remove the plating, its use is prohibited. Rubber, manila paper, and materials containing sulfur will tarnish medals, metal insignia, and metal buttons.

**6. CARE OF HORSE COVERS AND SADDLE BLANKETS.** Brush off hair, manure, and other foreign material and frequently expose the under side to the sun. The part of the folded-saddle blanket that has been next to the back of the horse should be cleaned daily by drying in the sun. The caked areas should then be worked between the hands and finally brushed. Because a stiff brush or curry-comb will wear off the nap of saddle blankets, its use is prohibited. Both horse covers and blankets may be washed as follows: Spread the blanket flat on a clean concrete or wooden surface, wash both sides by means of a nozzled hose, and scrub with a soft brush and dissolved soap. Again use the hose on both sides, and spread on a picket line or fence to dry in the sun. To disinfect, dip the article in a 2 percent

cresolin solution after washing it, and allow to dry thoroughly in the sun. While blankets are wet, they should be stretched as nearly as possible to their original shapes. The lines along which saddle blankets are folded should be varied frequently in order to avoid excessive wear along the fold.

**7. CARE OF CINCHAS OR GIRTHS.** Girths are made of textiles (web, line), mohair, or leather, which should be cleaned as are other articles made of similar materials. Because girths and cinchas are often saturated with sweat, they should be thoroughly cleansed and their leather parts should be recoiled more often than is ordinarily necessary for other items of equipment.

**8. CARE OF WEB EQUIPMENT.** Web equipment should be cleaned only by dry-brushing whenever possible. When necessary to use soap, use only Army all-purpose or white toilet soap and dry in the shade. Use of yellow issue soap, commercial cleaning fluids, dyes, or dressings is prohibited. Web equipment requiring recoloring will normally be dyed by installations of the Quartermaster Corps. When troops are authorized to recolor web equipment, they must use only recoloring agents issued by the Quartermaster Corps. While the web waist belt is wet, it should be stretched to its original length. To prevent mildew, dry web equipment thoroughly and air it before storing and at intervals during the period of storage. If mildew forms, brush it off with a stiff brush and air the item. To open snap fasteners on web equipment, place thumb and forefinger beneath the metal and pry upward. If the flap is pulled, the snap fastener may be loosened. Webbing straps on haversacks, canvas field bags, and field packs should not be so tight as to strain the fabric. Small holes in webbing must be repaired as soon as they are discovered.

**9. CARE OF CANVAS.** With a dry brush remove mud and dirt from items made of canvas (including leggings). If necessary, scrub with a brush dipped in clear water. Seams and buttonholes should be thoroughly cleaned. If articles are mildewed, stretch and examine them. Mildew must be removed with a dry brush, and the articles must be sunned and aired. Remove oil and grease by scrubbing with mild soap and warm water. The use of gasoline and solvents is prohibited.

**10. CARE OF WOOD.** When articles of unpainted wood, such as guidon staffs and modified McClellan stirrups become rough, they should be dressed down with fine sandpaper, revarnished to protect the surface from moisture, and rewaxed to protect the varnish. Wooden articles should be stored in a dry place.

**11. CARE OF MESS EQUIPMENT.** Keep mess equipment clean. Grease or food particles left on mess equipment can cause illness. Dirty mess equipment is also more likely to rust or corrode. To keep it clean—

a. Dip the mess gear in hot, soapy water and swish it around. Use a brush if one is provided. This washes off food particles and loosens the grease.

b. Rinse it in boiling clear water.

c. Rinse it again in a second container of boiling clear water.

d. Finally, swing it back and forth in the air until it is thoroughly dry.

e. If steel wool must be used, use it gently. Some mess items are made of steel and coated with another metal for protection. Rubbing too hard with steel wool or any abrasive removes the coating.

f. Don't wipe mess gear with a wet cloth.

g. Don't close the meat can before it is completely dry. That invites rust.

**12. CARE OF CANTEEN.** The canteen is easily kept in good condition by the following simple rules:

a. Keep the canteen drained and dry when not in use. Even a little water left inside for a while will corrode it slightly, or add taste and odor. If possible, dry thoroughly before replacing the cap.

b. Take care of the canteen cap. Keep it screwed on when the canteen is not in use. If this is not done, the cork liner inside the cap will dry out and become loose. It may fall out completely, and the canteen will then leak.

**13. CARE OF KNIVES.** Instructions on the care of various knives are given below:

a. **Pocket knife.** Sharpen it properly, using a sharpening stone if possible. Dry the blades after each use. Oil the hinges and springs occasionally.

b. **Knife, M-1926.** If the knife has a plastic handle, don't put any unnecessary strain on it such as would come from using it as a lever. The handle might split or break.

c. **Machete.** Insect repellent has a slightly solvent effect on the plastic handle. Don't let the two come in contact any more than necessary.

**14. CARE OF MISCELLANEOUS EQUIPMENT.** a. Cover, protective, individual. If an individual protective cover has been issued, keep it in the gas mask carrier. This item is fragile—it tears easily. The wrapper that comes with the cover, being fairly durable, offers some protection to the cover.

b. **Bag, clothing, waterproof and bag, food, waterproof.** (1) When these items become soiled, wipe them

with a clean cloth and then wash them with soap and water. To get the longest life out of the food bag and the clothing bag, wash the inside occasionally with soap and water and air the bag until it is thoroughly dry. This is especially important if dirty clothing or oily or greasy food, or equipment, has been stored in it.

- (2) Don't hang a filled clothing bag by its drawstring.
- (3) For further care of those items, see paragraph 3e.



## SECTION II

### BIVOUAC EQUIPMENT

---

**15. GENERAL.** Except in extremely cold or extremely warm, moist climates, wherein the two-man mountain tent and the jungle hammock (FM 20-15) are issued, men in the field use the shelter tent (composed of 2 tents, shelter half). Woolen sleeping bags (1 per individual) may be issued in lieu of blankets in theaters of operations in temperate climates. In mosquito infested areas, the mosquito bar is issued when authorized.

**16. TENT, SHELTER.** (FM 20-15.) **a. General.** The old-type shelter tent and the new-type shelter tent differ in one respect. The old has a single closure provided by a triangular piece of canvas sewed to one end of the shelter half, and the new has a double closure provided by triangular pieces of canvas sewed to both ends. When authorized for a unit, the shelter half is issued on the basis of 1 per enlisted man, with 1 tent pole, 5 tent pins, and 1 guy line; and 2 per officer, with 2 tent poles, 10 tent pins, and 2 guy lines. The tent, shelter half, is also used as a fly.

**b. Tent, shelter (old-type).** (1) *General.* The tent is made of light, water-repellent cotton canvas and is constructed in two sections, which are buttoned together to accommodate two men. It has a ridge height of 43 inches. The tent may be ventilated by opening the closed end.

(2) *Pitching.* (a) *General.* Instruction is given in formal tent pitching in order that commanders may establish their units quickly and that men may be taught to pitch tents in a short time. (See FM 22-5.) Except at inspection, tents are pitched on ground that will make cover and concealment possible and contribute to the comfort of the men. Two men should be able to erect this tent in about 5 minutes.

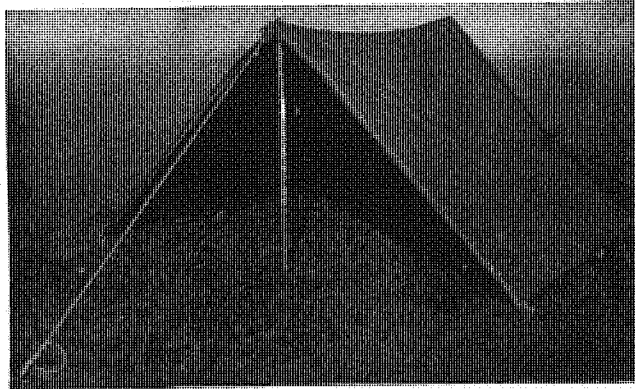


Figure 1. Tent, shelter (old-type).

(b) *Formal shelter tent pitching.* See FM 22-5 for formation of troops.

1. Pairs of odd- and even-numbered men pitch tents together (1 and 2, 3 and 4, etc.). When directed by the officer in charge, each odd-numbered man with his left heel makes a mark on the ground at the outside of his left heel near the instep. The front tent poles will be placed later at the positions thus marked.
2. At the command, "Pitch tents," each man, if armed with a rifle, takes one step obliquely to the right front and lays his rifle on the ground with muz-

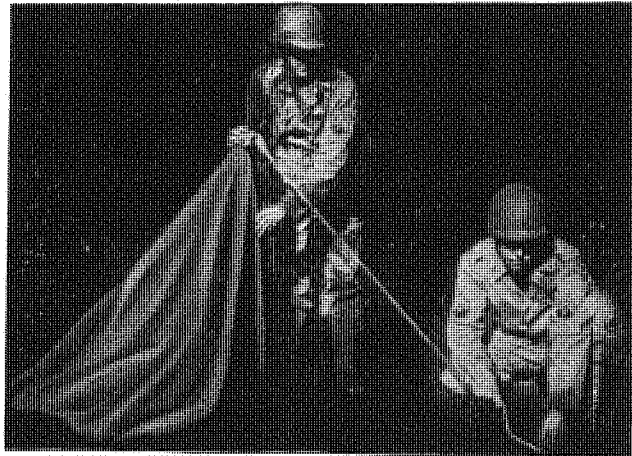
zle to the front, barrel to the left, and butt near the toe of his right foot. He then steps back into place. Immediately he unslings his equipment and places his pack or roll up and to the front on the ground 2 paces in front of him. He then takes from his pack his shelter half, pole, and pins. Each odd-numbered man drives a pin on the spot that he has marked. Each man of each pair then spreads his shelter half on the spot that the tent is to occupy, with buttons to the center and the shelter half of the even-numbered man on the left. One of the halves must be right side out and the other wrong side out so that the rows of buttons may be inserted into the button-holes. The letters "U.S." are stamped on the right side of the tent.

3. The shelter halves are then buttoned together. The odd-numbered man slips his pole into the eyelets in the front of the tent and holds the pole upright beside the pin. The even-numbered man pins down the front corners of the tent in line with the pins. He then drives a pin in front of the pole at a distance equivalent to a tent-pole length. He places the loop of the guy line over this pin and runs the other end of the line through the loops of the shelter halves and ties it, making sure that the pole is in a vertical position when the line is taut. He then adjusts the rear tent pole through the eyelets in the rear of the tent. The odd-numbered man pins down the rear corners of the tent, drives in the rear guy pin so that it is two and a half tent-pin lengths from the rear pin of the triangle, and then adjusts the guy line. The even-numbered

man pins down the left side of the tent, and the odd-numbered man, the right side.

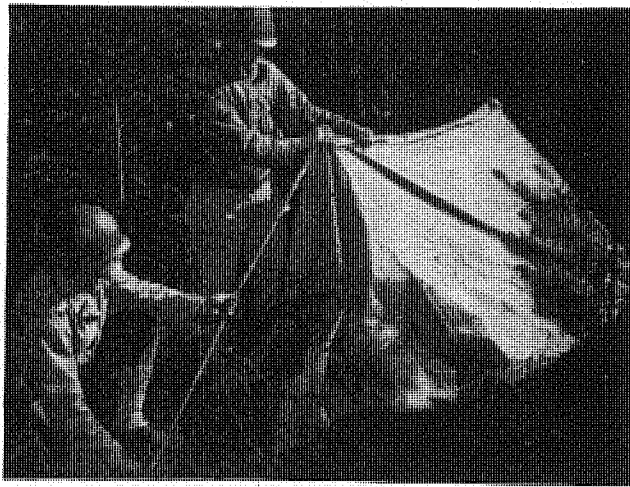
4. The duties of the odd- and even-numbered men are tabulated below:

| <i>Odd-numbered man</i>                                  | <i>Even-numbered man</i>                                |
|--|---|
| Marks spot for location of front tent pole.              | Spreads shelter half on left of spot tent is to occupy. |
| Drives pin for front tent pole on spot marked.           | Helps button shelter halves together.                   |
| Spreads shelter half on right of spot tent is to occupy. | Pins down front corners of tent. Drives front guy pin.  |
| Helps button shelter halves together.                    | Adjusts front guy line. Adjusts rear tent pole.         |
| Adjusts front tent pole and holds it upright beside pin. | Pins down left side of tent.                            |
| Pins down rear corners of tent.                          |   |
| Drives rear guy pin.                                     |   |
| Adjusts rear guy line.                                   |   |
| Pins down right side of tent.                            |   |

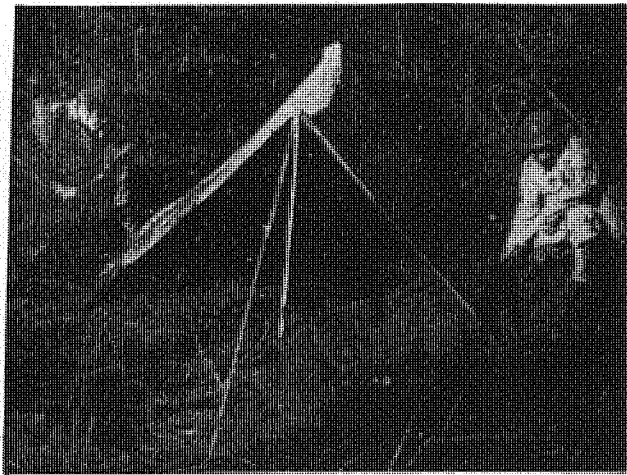


① *First step.*

*Figure 2. Three steps in shelter tent pitching.*



② *Second step.*



③ *Third step.*

*Figure 2. Three steps in shelter tent pitching (cont'd).*

(c) *Pitching double shelter tents.*

1. The double shelter tent consists of two old-type shelter tents buttoned together at the square ends. It is supported by three poles, one at the center and one at each end.
2. When directed by the officer in charge, one man makes a mark on the ground at the outside of his left heel near the instep and drives a pin into the spot. Four men spread their shelter halves on the place that the tent will occupy. They button the shelter halves together, the ridge first and then the square ends so that, from the bottom, the center eyelets will be in the following order: the lower half of the front tent, the lower half of the rear tent, the upper half of the front tent, and the upper half of the rear tent. One man supports the front pole in the position marked, and another man supports the rear pole in line with the front pole. The other two men pin down the rear and front corners of the tent. One man enters the tent and, with the assistance of another man, slips the pole through the center eyelets of the shelter half. Two men drive pins at each end of the tent, a tent-pole length from the corner pins and in line with the side pins, and adjust the guy lines to the pins and through the loops of the tent and fasten down the sides of the tent with the remaining pins.

(3) *Striking.* A sufficient number of buttons should be unfastened to enable the men to grasp the tent poles. Then the poles are permitted to fall either to the right or to the left. When the tent is down, the pins are pulled out and all buttons are unbuttoned. Tents should never be ripped apart since this ruins buttonholes.

**c. Tent, shelter (new-type).** (1) *General.* This tent is identical with the old-type shelter tent except that both ends are triangular and that it may be ventilated at one or both ends.

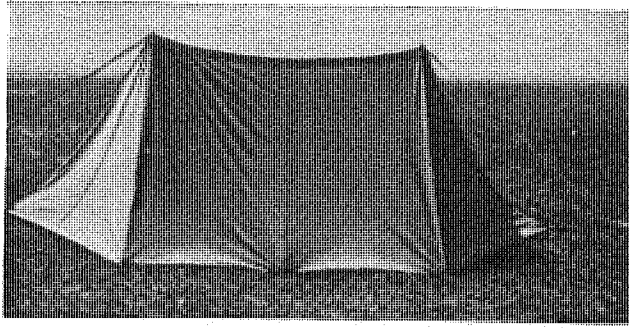


Figure 3. Tent, shelter (new-type).

(2) *Pitching.* The new-type shelter tent is pitched in the same manner as the old type (b(2) above), with the following exceptions:

(a) When the halves are spread preparatory to being buttoned together, both should be right side out, with the even-numbered man's shelter half to the left.

(b) After the first corner pins have been driven, the even-numbered man pins down the front of the tent and then drives the front guy pin two and a half tent-pin lengths from the front pin of the triangle.

(3) *Striking.* See (3) above.

**17. BAG, SLEEPING, WOOL, AND CASE, WATER-REPELLENT.** a. *General.* The woolen sleeping bag may be issued in lieu of woolen blankets. The sleeping bag is provided with a hood and a zipper opening. Both bag and case have eyelets, by means of which they are laced together.

The case has a snap closure. Although lighter in weight than one woolen blanket, the bag is as warm as the two blankets it replaces and warmer when used with the water-repellent case. (For making roll, see par. 21 b(2).)

**b. Use.** The placing of leaves, pine needles, or other foliage, a shelter half, or extra clothing beneath the bag will keep the sleeper warmer than the wearing of extra clothing. In warm weather the water-repellent case without the bag is adequate protection. The sleeper must keep his mouth and nose outside the bag in order that moisture from the breath will not dampen the blanketing. Whenever practicable, the bag should be opened and thoroughly aired. If the washable liner is issued, place it inside the bag with the hood flap outside and fasten the hood of the liner to the hood of the sleeping bag by means of the laces and the eyelets. When the case loses its water-repellent quality, it must be turned in for treatment by a quartermaster laundry.

**18. BARS, MOSQUITO.** Mosquito bars are issued in mosquito-infested areas. The body of the sleeper must not touch the netting. Beds and cots should be provided with overhead frames. When the net is used within small tents, its shape must be made to conform with that of the tent. The soldier who sleeps outdoors in malarious areas and is not provided with a jungle hammock must suspend mosquito bars from trees or bushes. Small holes in the netting must be repaired at once. Holes are repaired by placing a piece of net, tape or cloth over the damaged portion and sewing it to the netting around the hole.



## SECTION III

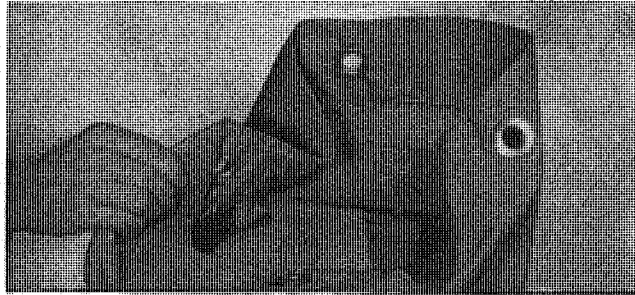
### METHOD OF ASSEMBLING AND PACKING EQUIPMENT

---

**19. GENERAL.** Clothing and equipment are carried in duffel bags, canvas field bags, haversacks and pack carriers, rucksacks, jungle packs, field packs, and cargo and combat field packs. The cargo and combat field pack is designed to supplant all other packs.

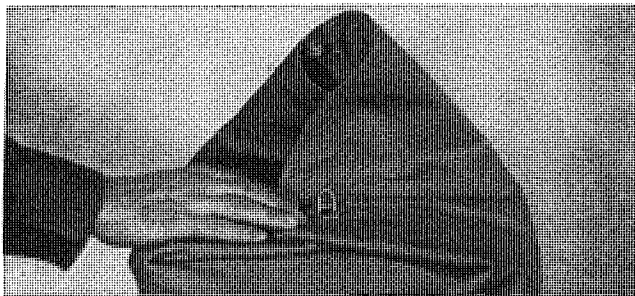
**20. BAG, DUFFEL. a. General.** The duffel bag is a large, durable container, which is easily carried. In it the soldier places all clothing that is not carried in his pack.

**b. Closing** (fig. 4). After the duffel bag has been packed, fold the flaps envelope-fashion. Slip the eyelets over

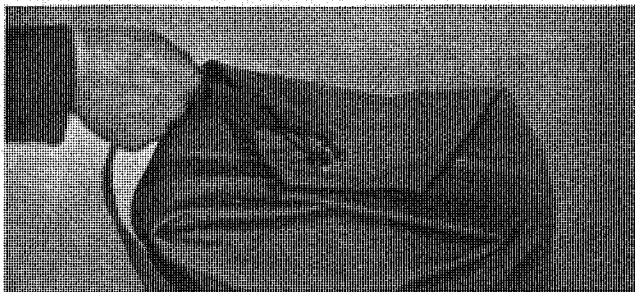


① *First step.*

*Figure 4. Closing duffel bag.*



② *Second step.*



③ *Third step.*

*Figure 4. Closing duffel bag (cont'd).*

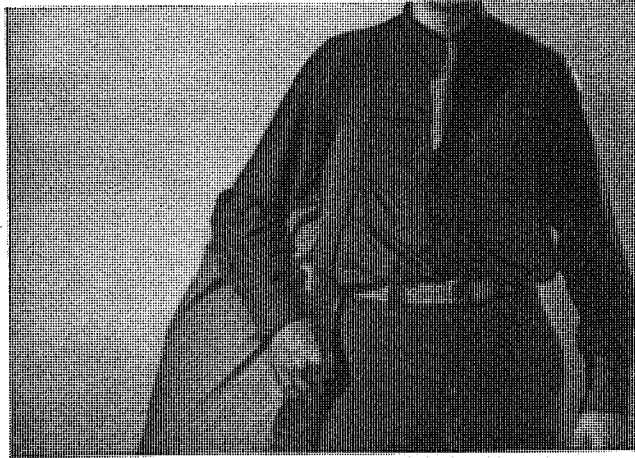
the U-hook and secure with the snap hook that is on the carrying strap. A padlock, though not issued, may be used to safeguard the contents of the bag.

c. **Carrying** (fig. 5). A soldier can carry the duffel bag by the handle as he would a suitcase or he can sling the strap over his shoulder and carry the bag caddy-style.

**21. ASSEMBLING AND ATTACHING HAVERSACK, M-1928, AND CARRIER, PACK, M-1928, AND ACCOMPANYING EQUIPMENT.** a. **General.** The haversack is made of cotton duck and webbing, and it is equipped with shoulder straps and tabs for attaching the

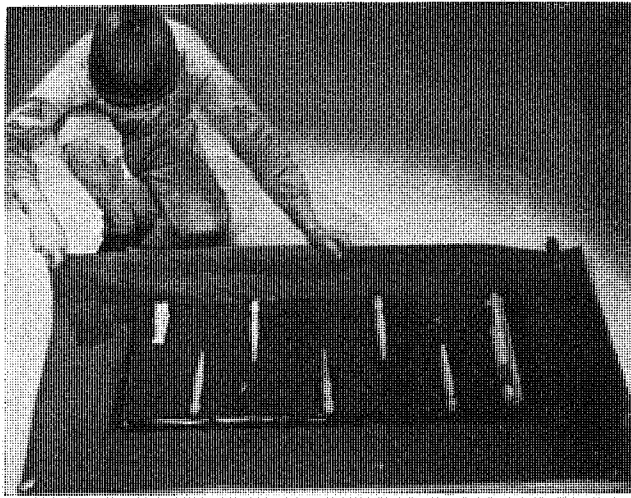


① *By hand.*

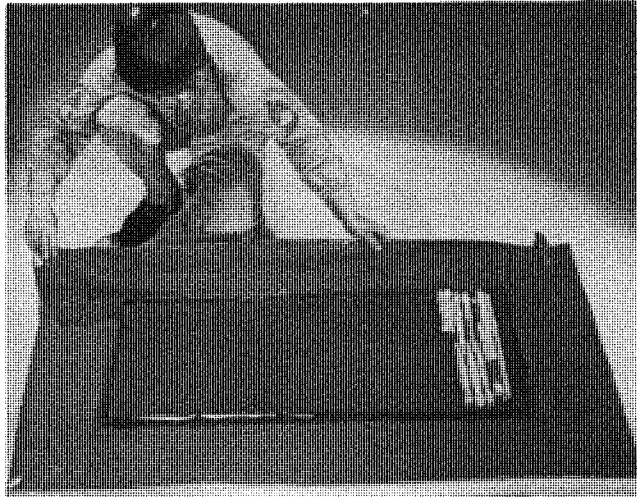


② *Over shoulder.*

*Figure 5. Carrying duffel bag.*



① *Arrangement of items.*

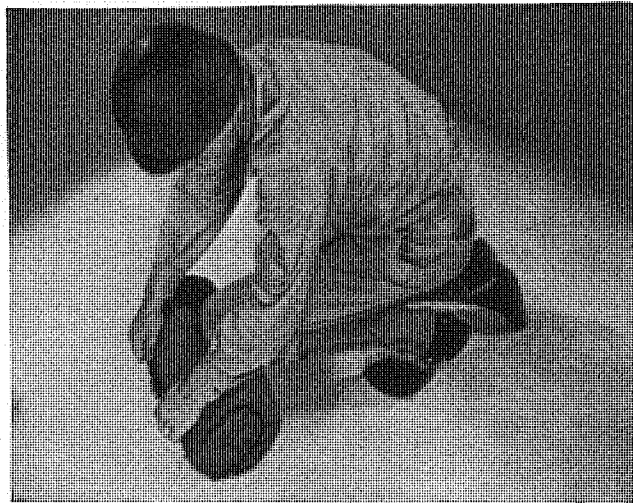


② *Alternate arrangement of items.*

*Figure 6. Making blanket roll.*

intrenching tools and bayonet. It is supplemented by the pack carrier, which is attached to the bottom of the haversack when a full field pack is carried.

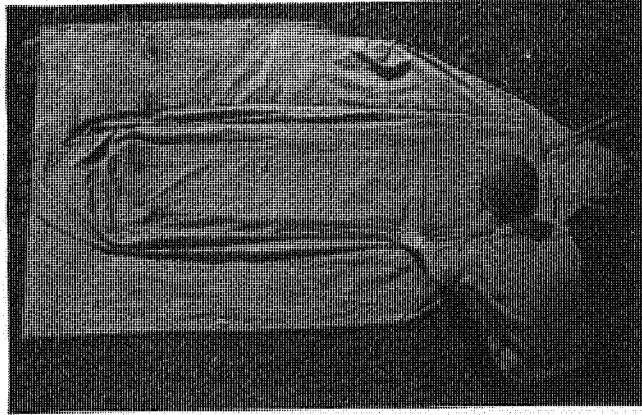
**b. Making roll.** (1) *When blanket is issued* (fig. 6). Spread the shelter half on the ground or floor, buttons up, and convert it into a rectangle by folding in the triangular end, or, if the new-type shelter half has been issued, by folding in both triangular ends. Halve the length of the tent by folding at the center. Fold the blanket in order to halve its width. Fold again so that it becomes one-fourth of its original width. Bring ends together and place blanket in the center of the folded shelter half. Place clothing neatly in the folds of the blanket and spread out to prevent bunching. Lay the tent pole at the folded end of the blanket. Alternate the tent pins as in figure 6① or place them together against the pole, heads and points alternated as in figure 6②. The sides of the shelter half and the end at which the pole is



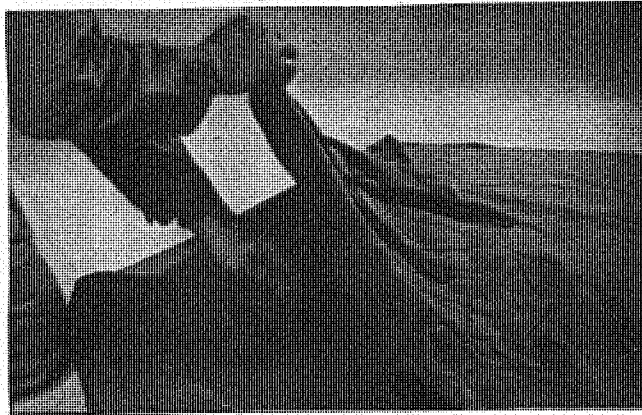
③ *Completing roll.*

*Figure 6. Making blanket roll (cont'd).*

placed should then be folded over the blanket. Make a 10-inch fold at the other end of the shelter half. Begin at the pole and roll tightly. Insert roll between the layers of the 10-inch fold, thus making an envelope fold. (See fig. 6③.)



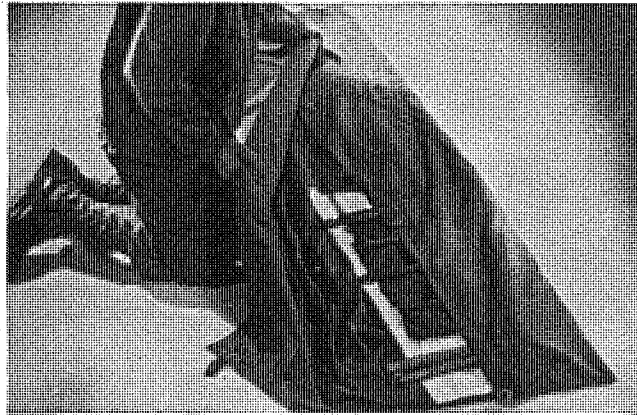
① *First step.*



② *Second step.*

*Figure 7. Making the sleeping bag roll.*

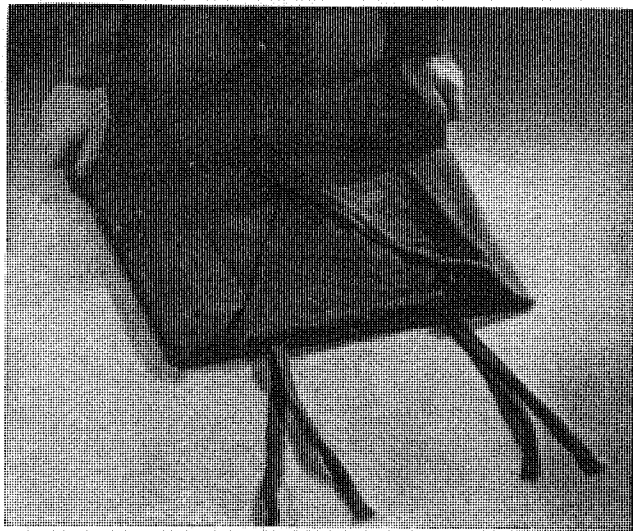
(2) *When woolen sleeping bag is issued* (fig. 7). Lay shelter half on ground or floor. Fit the sleeping bag into the waterproof case and draw straps of sleeping bag through the slits in the case. When the new type of shelter half is used, fold in one of the triangular ends at the base of the triangle, making it identical in shape with the old type. Stretch the sleeping bag in such a way that the zipper is at the side of the



③ *Third step.*

*Figure 7. Making the sleeping bag roll (cont'd).*

bag and lay the bag in the center of the shelter half. The top of the bag must be along the squared end of the shelter half, and the straps must be extended so that they are parallel with the sides of the shelter half. (See fig. 7①.) Fold the triangular end of the shelter half under the sleeping bag far enough to make bag and shelter half the same length. (See fig. 7②.) Lay clothing and toilet articles on the sleeping bag. Place the tent pole at the head of the bag and lay the pins as they are laid when the blanket is used. Fold the sides of the shelter half over the sleeping bag. (See fig. 7③.) Starting at the head, *roll tightly* toward the foot. (See fig.



④ *Fourth step.*

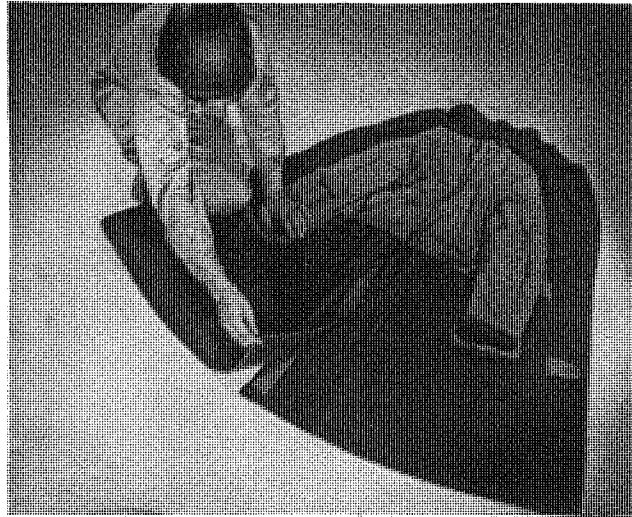


⑤ *Completing roll.*

*Figure 7. Making the sleeping bag roll (cont'd).*



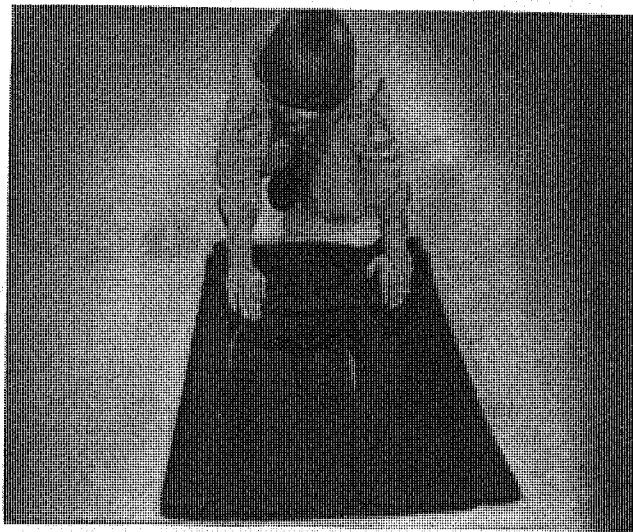
7④.) Tie the roll with the straps of the sleeping bag. (See fig. 7⑤.) If two sleeping bags are rolled, one is placed on top of the other, and the procedure is the same as that described for one bag. The straps of the bottom bag are used to secure the roll.



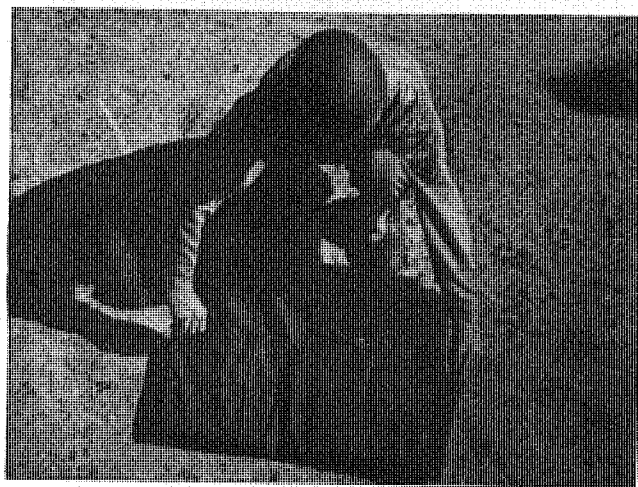
① *First step.*

*Figure 8. Folding overcoat.*

**c. Folding overcoat** (fig. 8). Turn sleeves inside out and place the overcoat on the floor or ground, outside down, coat smooth, collar extended, sleeves smooth and turned toward the pockets. Move the inside flap of the tail about 6 inches under the outside flap. (See fig. 8①.) Gather in the slack by tucking along the middle seam and tapering toward the collar. Grasp lower corners and fold toward the center of the coat about 12 inches. Make a 15-inch fold at the top (fig. 8②), and about a 9-inch fold at the bottom. (See



② *Second step.*



③ *Third step.*

*Figure 8. Folding overcoat (cont'd).*

fig. 8③.) Starting at the top, roll the coat smooth and tight and tuck the roll envelope-fashion into the bottom. (See fig. 8④.) The completed roll should be approximately 42 inches long.



④ *Completing fold.*

*Figure 8. Folding overcoat (cont'd).*

**d. Attaching pack carrier to haversack (fig. 9).** Spread haversack on the ground, inner side down, buttonholes toward you, pouch flap extended. Place buttonholed edge of pack carrier *under* buttonholed edge of haversack, "U.S." side of pack carrier up. Superimpose buttonholes of haversack upon corresponding ones of pack carrier. Insert coupling strap through center holes of both haversack and pack carrier. Lace pack carrier to haversack by passing the ends of the coupling strap, dressed side up, through corresponding buttonholes of haversack and pack carrier.

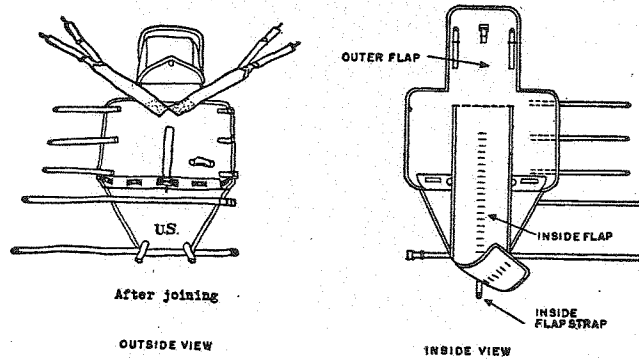
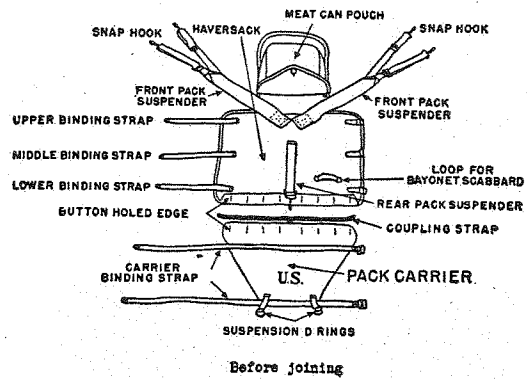
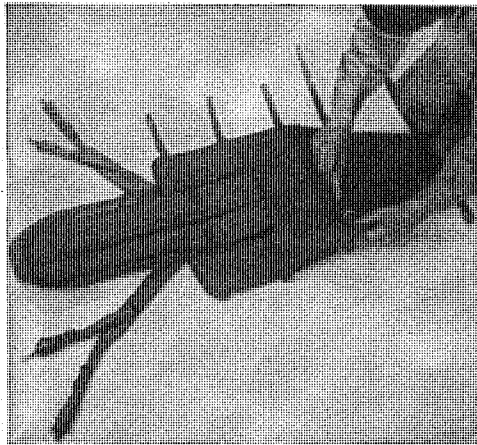


Figure 9. Haversack and pack carrier.

e. Packing haversack (figs. 10 and 11). (1) *When rations are carried.* Place haversack and pack carrier on the ground. The inside of the haversack should be up. The haversack must be spread out, and the pack carrier and inside flap of the haversack must be extended to their full length. (See fig. 10①.) Place roll on extended haversack<sup>2</sup> and pack

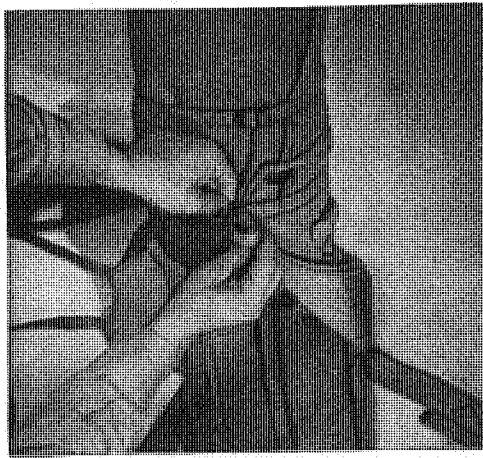
carrier, with the opening of the roll down and the end of roll even with bottom of pack carrier. Fasten lower carrier binding strap by passing strap up through the buckle opening that is farthest from the buckle attachment, over the center bar, and down through buckle opening that is nearest the buckle attachment. Place loose end of strap neatly beneath that portion of the strap that is around the roll. Fasten the



① *First step.*

*Figure 10. Haversack packed with rations.*

upper carrier binding strap and the lower haversack binding strap in like manner. (See fig. 10②.) In order to make a pocket for rations, pass the inside flap strap under the lower haversack binding strap and the upper carrier binding strap and press the flap down against the top of the roll. Slip the middle and upper haversack binding straps through the most convenient loops of the inside flap, up through the buckle holes that are nearest the attachments, over the center bars, and down through the buckle openings that are farthest from



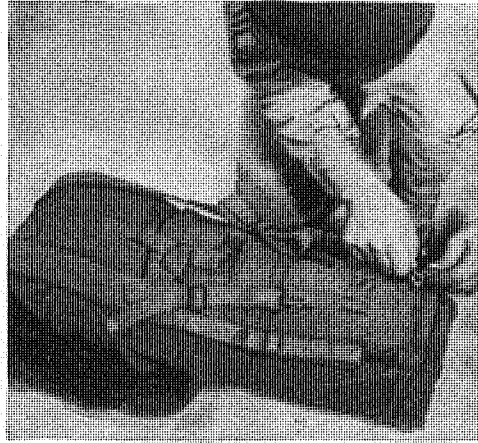
② *Second step.*



③ *Third step.*

*Figure 10. Haversack packed with rations (cont'd).*

the attachments. Fasten loosely and push the haversack inside flap against the middle and upper haversack binding straps. Stand pack on end of roll, with buckles on the outside and the outer flap folded toward you. In the pocket formed, pack rations as snugly as possible. Place toilet articles on top of rations. (See fig. 10③.) Fold haversack flap over toilet articles and tuck in. Tighten upper and middle haversack binding straps. Fasten the inside flap strap



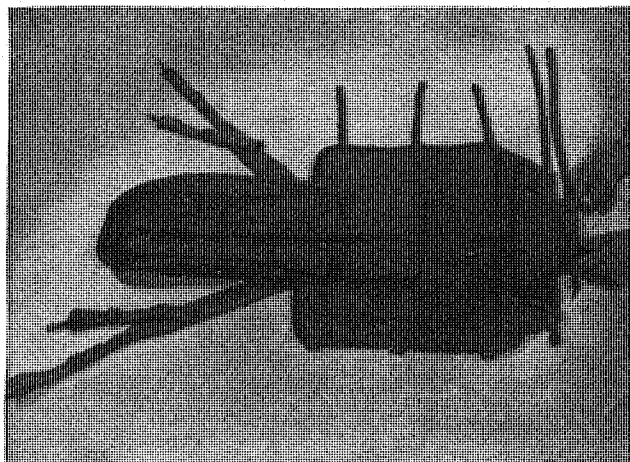
④ Assembled pack.

Figure 10. Haversack packed with rations (cont'd).

of the haversack to the buckle that is provided under the outer flap. Engage the snap hooks of the longer front pack suspenders in the lower suspension rings. (See fig. 10④.)

(2) *When rations are not carried.* Fold pack carrier onto haversack, creasing at the place where the upper carrier binding strap is sewed on. Fold bottom of carrier back toward you so that the D-rings will lie on the ground. (See fig. 11①.) Place roll on haversack and pack carrier. The end of the roll should touch the D-rings, and the opening

of the roll should be down. Fasten upper and lower carrier straps as in (1) above. Fasten lower and middle haversack straps in like manner. Place inside flap strap under middle haversack binding strap. Place toilet articles at top of the haversack inside flap and roll tightly against the roll. (See fig. 11②.) Secure the upper haversack binding strap and



① First step.

Figure 11. Haversack packed without rations.

the outer flap as in (1) above. Fasten the snap hooks of the longer front pack suspenders into the suspension D-rings.

**f. Belts.** (1) *Belts, pistol or revolver, M-1936* (fig. 12).

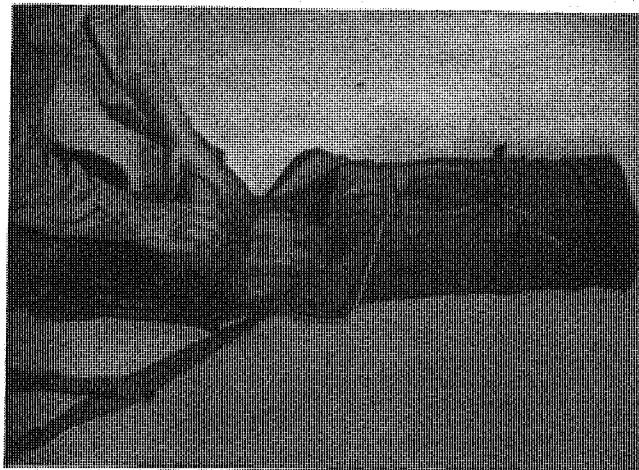
(a) *General.* Pistol or revolver belts are issued to enlisted personnel who are armed with pistols, revolvers, or carbines.

(b) *Method of assembling.* Place the belt on the ground, outer side down. Insert hook and through sliding keeper, then through unattached male buckle with stud down. Double the belt back through the sliding keeper and secure



the hook end in the eyelet that will give the right length. Slide the magazine pouch over the female buckle and fasten it to the belt. Hook the canteen to the bottom eyelets of the belt at left rear and fasten the first-aid pouch at right front in the same manner. In putting on the belt, a man holds the male buckle in his right hand.

(2) *Cartridge or magazine belts* (fig. 13). (a) *Belts,*



② *Second step.*

*Figure 11. Haversack packed without rations (cont'a).*

*cartridge, caliber .30, M-1923, dismounted or mounted.* These cartridge belts are issued to persons who are armed with rifles and who are not furnished other cartridge belts.

(b) *Belts, magazine, BAR M-1937.*—These belts are issued to all persons armed with automatic rifles.

(c) *Method of assembling.* Place the adjusting strap on the ground. The eyeleted edge should be toward you; pocket sections should be in line with the adjusting strap; the bottom of the pockets should be down; and the tops of the

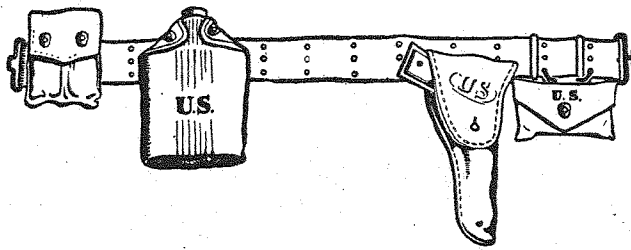


Figure 12. Pistol belt.

pockets should be toward you. Run the adjusting strap through the metal guide, then down through the buckle hole that is farthest from the buckle attachment, under center bar, and up through buckle hole nearest the buckle attachment. Engage the hooks that are on the ends of the adjusting strap in the eyelets that are on the inner surface of the belt. The belt should be loose about the waist so that when buckled it will rest over the hip bones and below the pit of the stomach. Care should be taken that adjustments are made equally from both ends of adjusting strap so that center eyelet will be in the middle of belt. The proper position of the belt is the same, whether filled or empty. Canteen and first-aid pouch are attached as in f(1)(b) above.

(d) *Opening pocket flaps.* Place thumb on stud of fastener and index finger under female section of fastener. Press downward with thumbs and upward with fingers until fastener is released.

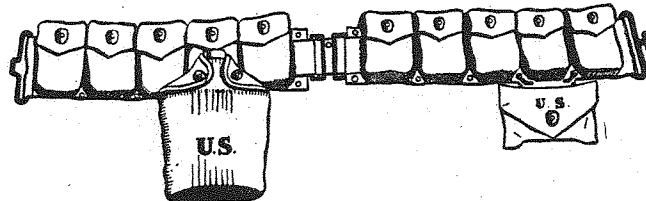
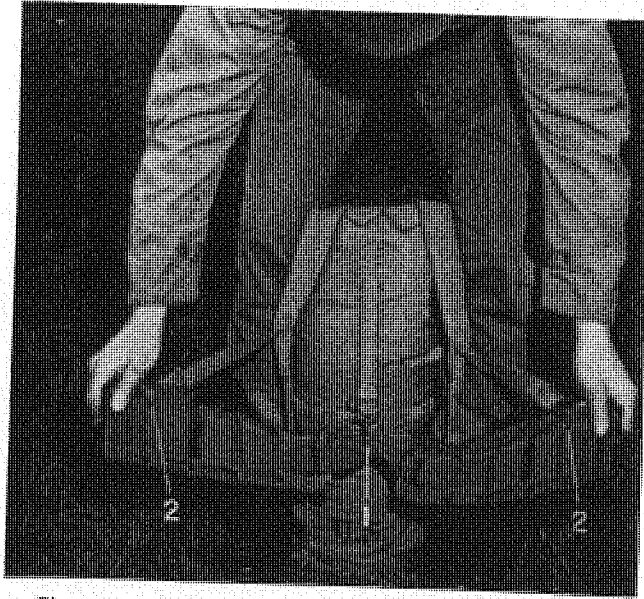


Figure 13. Cartridge or magazine belt.

**g. Attaching haversack.** (1) *To cartridge or magazine belt* (fig. 14). Place assembled haversack and pack carrier on the ground, outer side down. Place belt along the junction of haversack and pack carrier, inside up, openings of pockets upward toward the meat can pouch. The snap fastener on the rear pack suspender is then hooked into the outside of the upper eyelet at the rear of belt, approximately

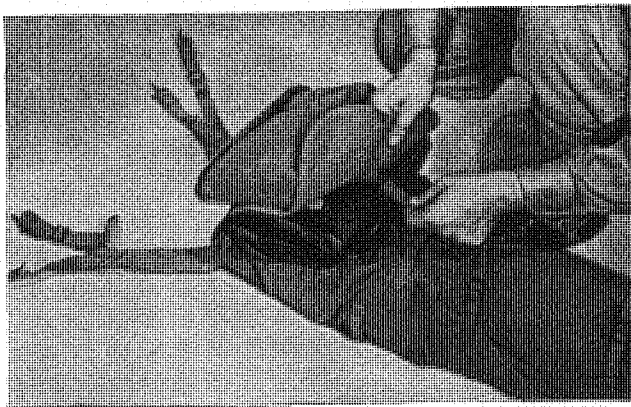


*Figure 14. Attaching haversack to cartridge or magazine belt.*

in the middle. (See (1), fig. 14.) Insert snap fasteners of the shorter front pack suspenders into the eyelets that are provided, between the first and second pockets at each end of the belt. (See (2), fig. 14.) The points of the front snap fasteners must be on the outside of the belt, and the suspenders must be flat against the body.

(2) *To pistol or revolver belt.* The procedure for adjusting the haversack to the pistol or revolver belt is identical with that for adjusting it to the cartridge belt with one exception: The hooks on the ends of the front belt suspenders are inserted into the eyelets that provide the most comfortable fit.

**h. Attaching bayonet scabbard.** Pass the lower end of the scabbard through the loop that is on the side of the



*Figure 15. Attaching raincoat to haversack.*

haversack. Engage double hook attachment in the eyelets on the outer side of the haversack, inserting the hook from the under side. Place bayonet in scabbard, ring to the rear.

**i. Attaching raincoat** (fig. 15). Fold the raincoat, outside exposed, into a rectangle of about  $10\frac{1}{2}$  by  $8\frac{1}{2}$  inches and place it under the outer haversack flap. Secure by passing outer strap under lower binding straps and fastening by means of the buckle that is inside of the outer haversack flap.

**j. Attaching overcoat** (fig. 16). Place the rolled overcoat on top of the haversack, open side of roll down. The overcoat should be behind the bayonet handle, and the center seam of the overcoat should be over the center of the top of the haversack. Turn the ends of the roll downward, and with the shelter half rope bind them against the side of the haversack, using a half hitch near each end of the overcoat, and passing the rope beneath the fastening of the closed pouch flap of the haversack. (See fig. 16.)



*Figure 16. Attaching overcoat to haversack.*

**k. Attaching helmet.** Attach and secure the helmet by placing the chin strap over the meat can pouch.

**l. Attaching intrenching tool** (fig. 16). Fold the pouch flap of the haversack so that the meat can pouch is uppermost; with handle of tool toward the D-rings, pass the tool carrier underneath the meat can pouch and engage the hook attachment in the eyelets that are provided in the flap,

inserting hooks from the under side. Secure the tool to the roll by means of the lower haversack binding strap.

**m. Adjusting full equipment.** Slip the arms through the pack suspenders as through the sleeves of a coat. By means of the adjusting buckles on the belt suspenders, raise or lower the belt until it is over the hip bones and below the pit of the stomach. Raise or lower the belt in the rear until the adjustment strap is across the small of the back. By means of the adjusting straps on the pack suspenders, raise or lower the load until the top of the haversack is on a level with the top of the shoulders.

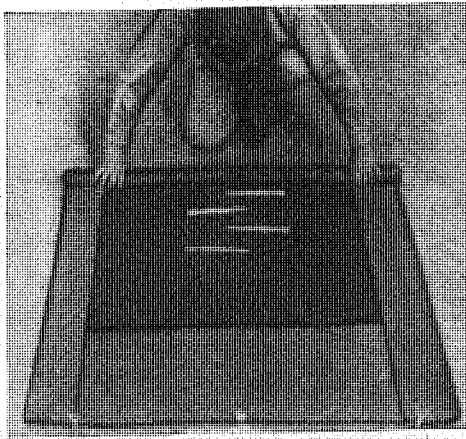
**n. Wearing gas mask.** For the wearing of the gas mask, see FM 21-40.

**o. Discarding roll without removing equipment from body.**—Unsnap the pack suspenders from the suspension rings and snap them into eyelets on top of the belt and behind the rear pockets of the right and left pocket sections. Support the bottom of the pack with the left hand. With the right hand grasp the coupling strap at the middle and withdraw first one side and then the other. Pull down on the roll with both hands and remove it. When the roll has been removed, lace coupling strap through buttonholes that are along the upper edge of the carrier.

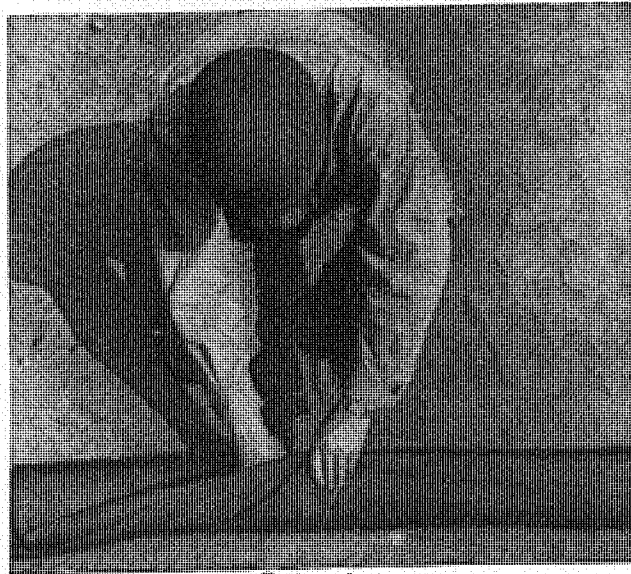
## **22. ASSEMBLING AND ATTACHING BAG, CANVAS, FIELD, OD M-1936, AND ACCOMPANYING EQUIPMENT.**

**a. General.** The canvas field bag is a more recent development than the haversack and a more convenient piece of equipment for soldiers who are transported in vehicles. This small bag can be attached to the shoulders by means of a carrying strap or may be worn on the back fastened to suspenders.

**b. Making a horseshoe roll (fig. 17).** (1) The horseshoe roll may be used with the canvas field bag or with any



① First step.



② Second step.

Figure 17. Making horseshoe roll.

field pack, or it may be carried alone, slung over the shoulder. The length of the roll is not prescribed but varies according to the amount of clothing and equipment carried and the type of pack with which the roll is used

(2) Put the shelter half flat on the ground.

(3) If blankets are used, fold them once both lengthwise and crosswise. If a woolen sleeping bag is used, lay the bag as flat as possible and fold it once to reduce the length by half. Lay the blankets or woolen sleeping bag on the center of the shelter half with the long edges parallel to the long edges of the shelter half.

(4) Place clothing or equipment inside the folds of the blankets or woolen sleeping bag evenly spaced and flat, so that they will not interfere with the rolling of the roll.

(5) Fold the triangular end or ends of the shelter half under the blankets or woolen sleeping bag to make the roll the desired length, ordinarily to the edge of the blanket or woolen sleeping bag.

(6) Fold over the long edge with buttons and roll tight towards the edge without buttons. Fold the far side in about 10 inches. Continue to roll and slip the roll into the folded end (envelope roll). It must be tight to hold.

(7) Tie the shelter half rope firmly around the roll about 3 inches from the end. Force the roll into the desired horse-shoe shape and tie the rope firmly about 3 inches from the other end to hold it in shape.

**c. Packing bag, canvas, field.** Place soft articles against the rear of the bag in order to keep the back from being rubbed or chafed. When rations are carried, they should be packed on the top of other equipment on the side away from the body so that they will be readily available.

**d. Attaching suspenders, belt, M-1936, to arms belt.** Fasten the rear straps (two snap hooks) to the top eyelets on the back of the arms belt that will effect a

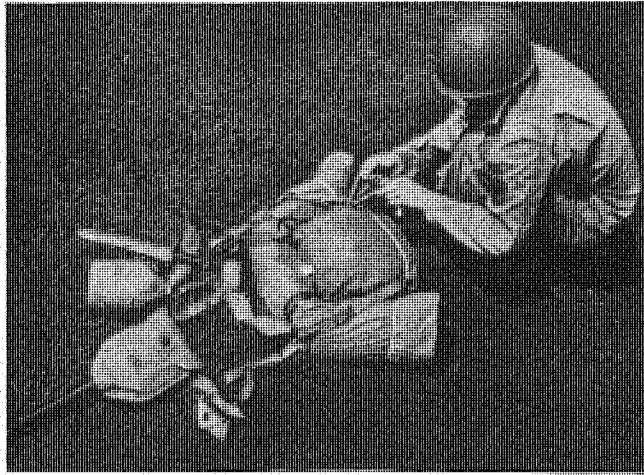


comfortable fit. In the same manner, fasten the inside front suspender straps to the top front eyelets of the arms belt.

**e. Attaching bag, canvas, field to suspenders.** Snap the straps on the top of the canvas field bag to the D-rings on the suspenders. Snap the outside suspender straps into the D-rings at the bottom corners of the bag.

**f. Adjustment.** Adjust all suspender straps for maximum comfort.

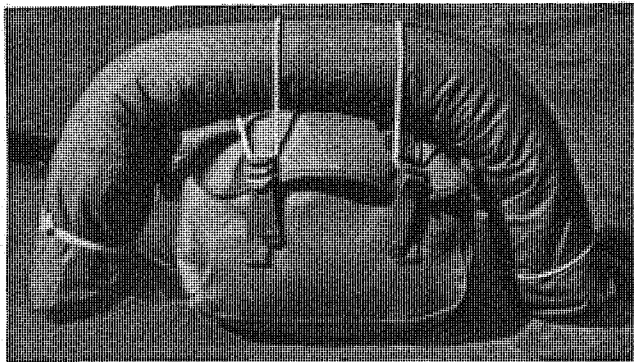
**g. Attaching horseshoe roll to bag, canvas, field** (fig. 18). The canvas field bag is not specifically designed to carry a roll. However, when the capacity of the bag itself is insufficient, a horseshoe roll may be attached. It is preferable to use the shelter half rope and an additional cord of about the same length, with which each soldier should provide himself. Before the shelter half rope, which



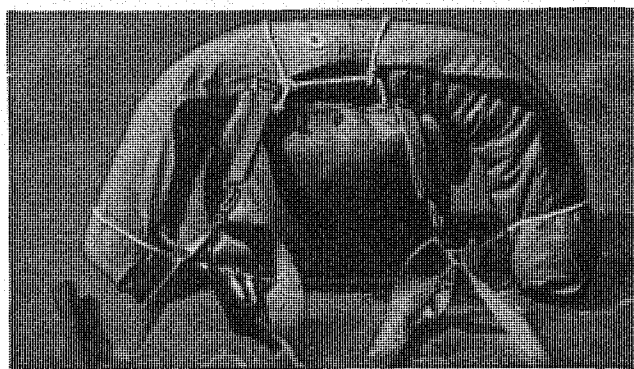
① *First step.*

*Figure 18. Horseshoe roll attached to canvas field bag.*

has been looped around one end, is attached to the other end, it should be run through the D-rings at the bottom corners of the bag. (See fig. 18①.) The auxiliary cord is then run behind one of the straps attached to the top of the bag, under the roll, under the cover flap strap and back over the roll to the loose end where it is tied. It is then run around the strap



② Front view.



③ Rear view.

Figure 18. Horseshoe roll attached to canvas field bag (cont'd).

that is attached to the top of the bag on the other side, and the process is repeated. (See figs. 18② and ③.)

**h. Carrying raincoat or poncho.** The folded raincoat or poncho may be placed either in the outside pocket or under the cover flap of the bag.

**i. Carrying other equipment.** Other equipment is normally carried on the cartridge belt. The bayonet is attached over the left hip, the intrenching tool on the right hip, the first-aid pouch in front of the intrenching tool (right front), and the canteen behind the bayonet (left rear). The magazine pouch is worn on the left front of the pistol or revolver belt.

**23. ASSEMBLING AND ATTACHING RUCKSACK AND ACCOMPANYING EQUIPMENT.** See TM 10-275.

**24. ASSEMBLING AND ATTACHING JUNGLE PACK.** See applicable War Department publications.

**25. ASSEMBLING AND ATTACHING PACK, FIELD, AND ACCOMPANYING EQUIPMENT.** **a. General** (fig. 19①). The field pack has a cylindrical main pouch covered by a large flap, which has a separate pocket with a zipper closure. Horizontal and vertical straps enable the pack to be adjusted to the size of the load.

**b. Belts.** (1) *Pistol or revolver.* See paragraph 21f(1).

(2) *Cartridge or magazine.* See paragraph 21f(2).

**c. Attaching pack to arms belt.** Fasten to the front of the belt the snap hooks that are suspended from the shoulder straps and fasten to the rear of the belt the snap hooks that are attached to the middle of the back of the pack. When it is necessary to ventilate the body, leave the belt unbuckled and the pack suspended from the shoulders.

**d. Adjusting size of pack.** (1) *General.* After the pack is filled, tighten the adjustment straps that run horizontally and vertically around the pack and make the load as compact as possible. The two vertical straps hold down the cover flap and control the length of the pack, and the horizontal straps control the diameter. Always keep buckles fastened to prevent their rattling.

(2) *Short pack* (figs. 19② and 20). To shorten the pack, lay it on the ground with shoulder straps uppermost; unhook the bottom ends of the shoulder straps from the lower set of D-rings; pull the vertical adjustment straps through the slide buckles, which are normally on the front of the pack about 6 inches above the bottom. While tightening the adjustment straps, fold the bottom of the pack neatly; snap the shoulder straps into the upper set of D-rings.



① *Full pack.*

*Figure 19. Field pack.*

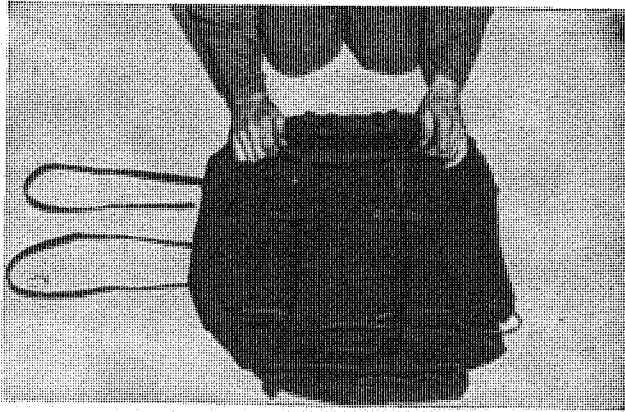


② *Short pack.*

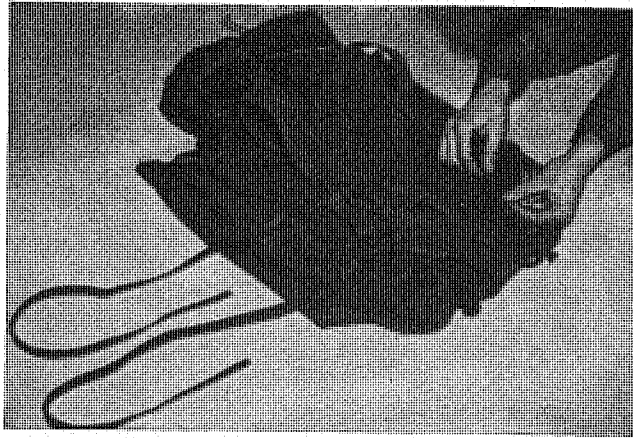


③ *Combat pack.*

*Figure 19. Field pack (cont'd).*



① *Folding bottom of pack.*



② *Snapping shoulder straps into D-rings.*

*Figure 20. Shortening field pack.*

(3) *Combat pack* (fig. 19③). The procedure for adjusting the combat pack is the same as that for adjusting the short pack except that the flap is pulled down so that the flap buckles rest on the upper set of D-rings, and the shoulder straps are snapped into both the flap buckles and the D-rings.

**e. Attaching intrenching tool.** Attach intrenching tool to the center tab on the flap of the pack, securing the handle under the horizontal adjustment straps.

**f. Attaching bayonet.** Slip bayonet scabbard under the loop on the left side of the pack and hook it into the tab on the cover flap that is near the left shoulder.

**g. Attaching canteen.** See paragraph 21f(1)(b).

**h. Attaching first-aid pouch.** See paragraph 21f(1)(b).

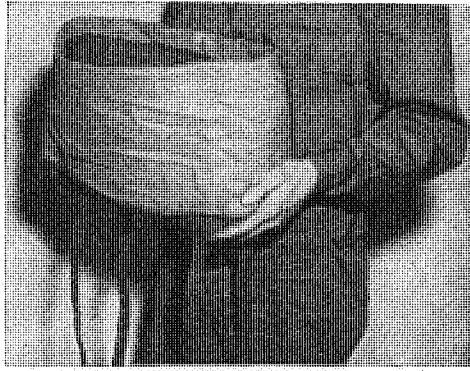
## **26. ASSEMBLING AND ATTACHING PACK, FIELD, CARGO AND COMBAT, ACCOMPANYING EQUIPMENT.**

**a. General.** The cargo and combat field pack consists of the combat pack (upper bag), the cargo pack (lower bag, which is larger and has a webbing handle at the top), and the suspenders. The suspenders may be used without either bag to support the cartridge belt, with the combat pack, or with both bags to form a full pack.

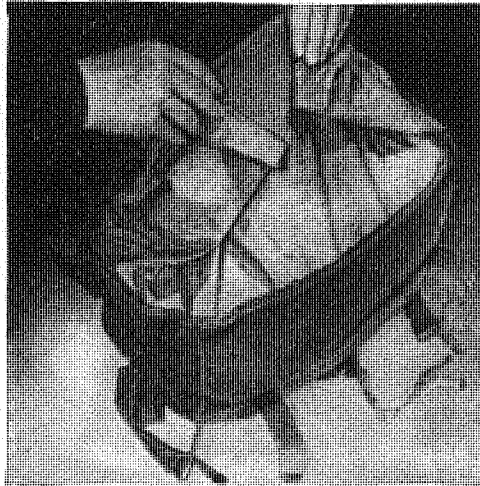
**b. Assembling belts.** See paragraph 21f.

**c. Packing.** (1) *General.* There is no special position for most articles, but the pack should be filled carefully to keep from wasting space between items and to keep the pack compact. Soft items should be packed around hard or sharp objects to protect the soldier's back and to prevent such objects from damaging the pack itself.

(2) *Waterproof throat.* Before anything is placed in either bag, the waterproof throat should be pulled out and turned back over the outside of the pack so that the bag can be packed without any chance of catching the waterproof



① *First step.*



② *Second step.*

*Figure 21. Folding waterproof throat of cargo and combat field pack.*



material under the articles packed. (See fig. 21①.) After the bag has been filled, the corners of the waterproof throat are folded in envelope-fashion (fig. 21②), and the whole throat is folded over several times to insure a watertight closure. (See fig. 21③.)

(3) *Combat pack*. Articles needed in combat are placed in the combat pack. The inside of this bag is divided into

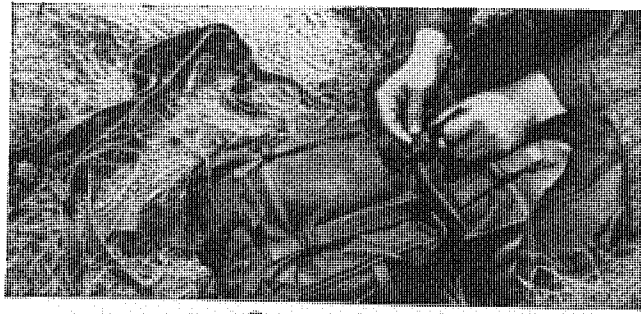


③ *Third step.*

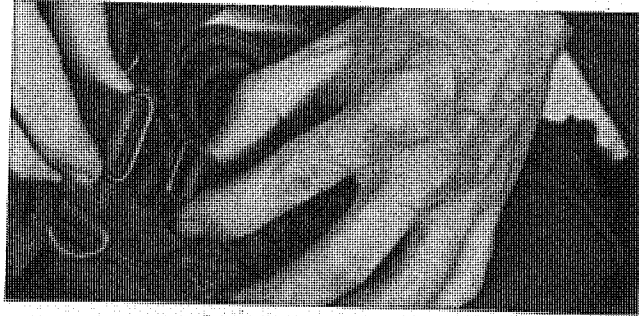
*Figure 21. Folding waterproof throat of cargo and combat field pack (cont'd).*

two main sections. The meat can is placed in the section away from the soldier's back. Rations are carried in the pockets, which are found inside the bag on both sides. Small articles that are needed frequently are placed in the small outer pocket on the outside of the bag.

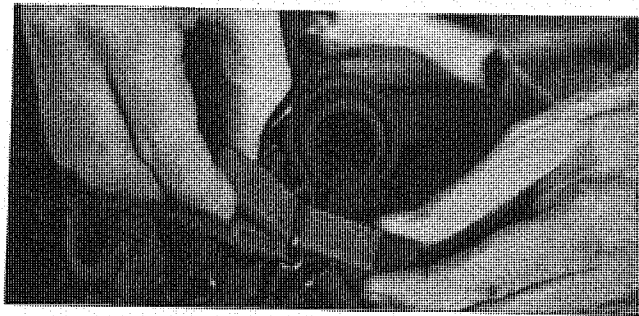
(4) *Cargo pack*. Articles not needed in combat are placed in the cargo pack.



① *Over-all view.*



② *Detailed view—first step.*



③ *Detailed view—second step.*

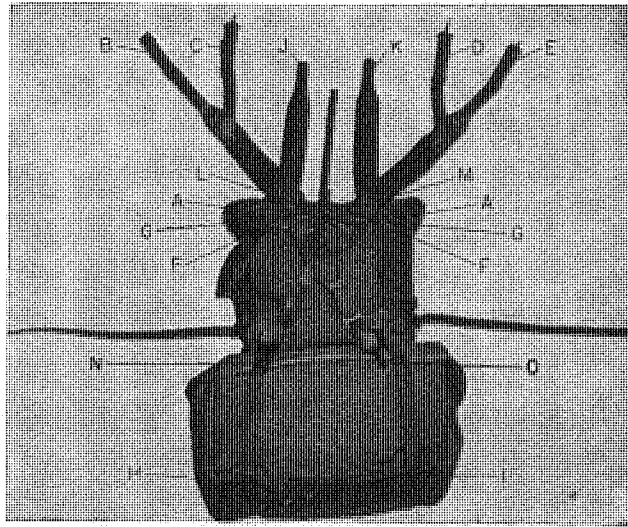
*Figure 22. Joining cargo and combat packs.*

(5) *Horseshoe roll*. A horseshoe roll may be attached to the combat pack. This is assembled as in paragraph 22b.

**d. Assembling pack.** (1) *Combat pack and cargo pack* (fig. 22). Place both bags, flap side up, on a flat surface with the bottom of the combat pack against the top of the cargo pack. Attach the quick-release strap that is fastened to the center of the cargo pack below the flap to the metal loop on the bottom of the combat pack. To do this, place the large loop on the cargo pack strap over the smaller metal loop on the combat pack and fasten it by pulling the metal-tipped strap through the smaller loop. Attach the quick-release straps on both sides of the cargo pack in the same manner. Turn the bags over and attach the quick-release strap on the middle of the back of the cargo pack. Pull up the loose ends of the adjustment straps below each quick-release assembly to hold the two bags tightly together.

(2) *Suspenders and pack* (fig. 23). Unbuckle the cross strap *A* at the top of the combat pack on the side that rests against the back. Lay the suspenders on the pack, flat side up, with the four snap hooks *B*, *C*, *D*, and *E* at the top. (See fig. 23①.) Place one of the three sets of loops *F* found on the under side of the suspenders directly over the cross strap *A*. Rethread the cross strap through all the loops *G* on the combat pack and through the set of loops on the suspenders that effect the most comfortable fit. (See fig. 23②.) Fasten cross strap *A* into cross-strap buckle. Snap the two main straps *B* and *E* on the top end of the suspenders into the *D*-rings *H* and *I* on the cargo pack. (See fig. 23③.) Attach the wide webbing top straps *J* and *K* of the combat pack to the double bar buckles *L* and *M* on the top end of the suspenders. (See fig. 23④.)

(3) *Cartridge belt and suspenders* (figs. 23 and 24). Snap the bottom ends (two snap hooks *N* and *O* fig. 23①) of the suspenders into the eyelets on the back of the cartridge belt

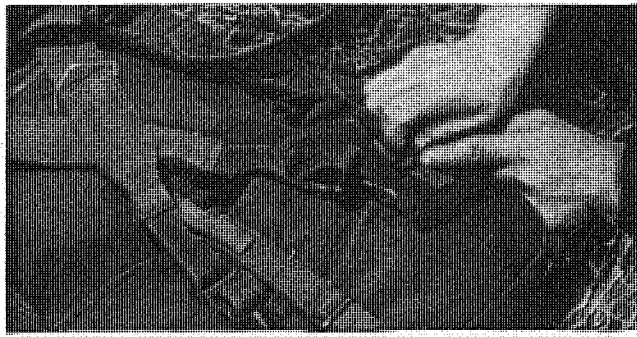


① Packs with suspenders in position for attaching.



② Threading cross strap through loops of suspenders.

Figure 23. Attaching cargo and combat field pack to suspenders.



③ *Snapping main straps of suspenders into D-rings of cargo pack.*



④ *Attaching webbing top straps of combat pack to buckles on top end of suspenders.*

*Figure 23. Attaching cargo and combat field pack to suspenders (cont'd).*

that effect the most comfortable fit. Snap the two straps *C* and *D* that are sewed to the main shoulder straps into the eyelets on the front of the cartridge belt that effect the most comfortable fit.

(4) *Horseshoe roll* (fig. 26). Place the horseshoe roll (par. 22b) around the top and sides of the combat pack and fasten by means of the straps at the top and at both sides.

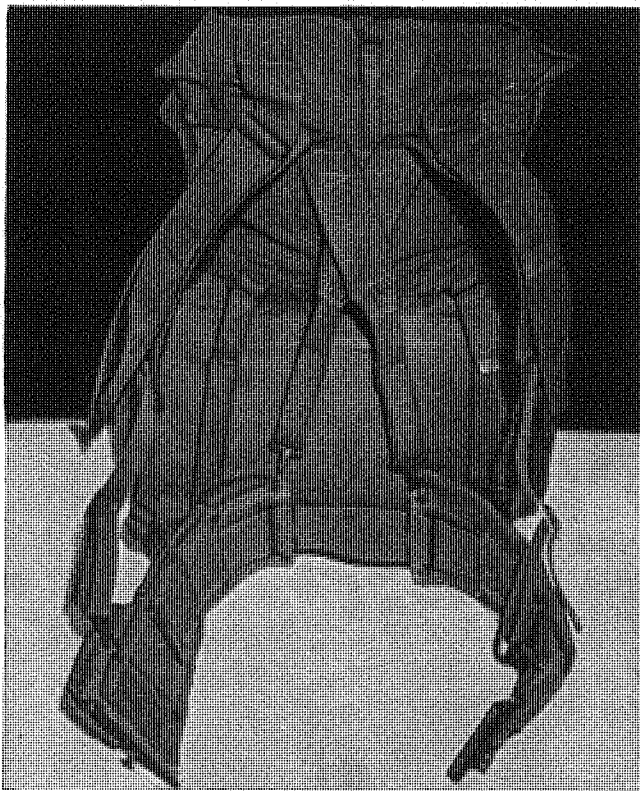
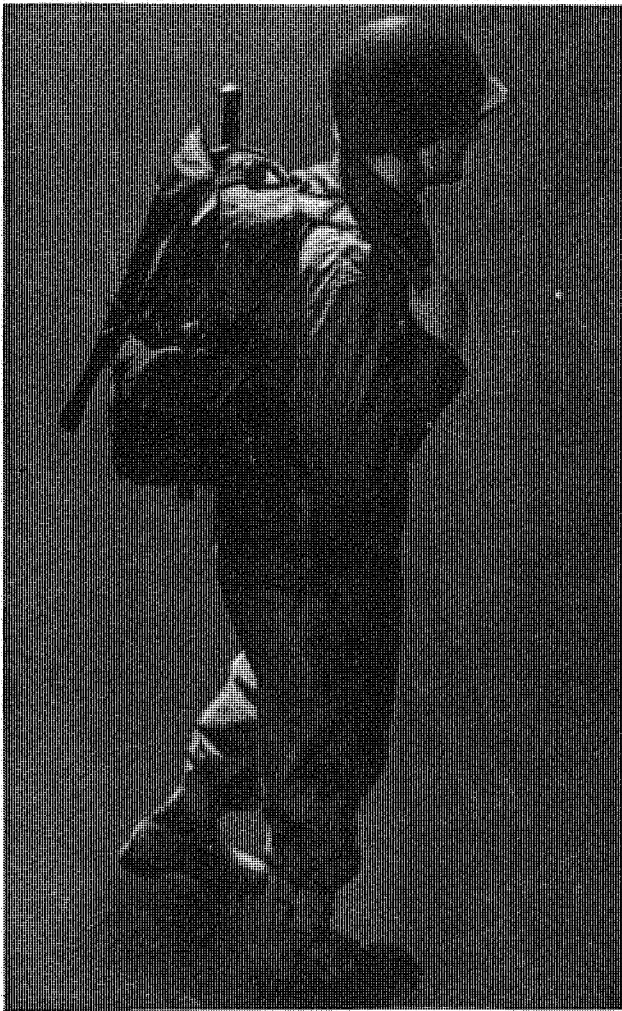


Figure 24. Attaching cartridge belt to suspenders.

When the roll is not carried, these straps should be buckled and the ends wrapped neatly.

(5) *Intrenching tool* (figs. 25 and 26). Attach the intrenching tool to the tab in the center of the flap on the combat pack and slip the top blanket-roll strap through the loop on the back of the shovel cover. Fasten the strap at the bottom of the combat pack around the handle of the in-



*Figure 25. Cargo and combat field pack.*

trenching tool. In threatening weather the raincoat or poncho may be inserted under the combat pack cover flap straps or under the intrenching tool before the handle is strapped in place.



*Figure 26. Combat pack with blanket roll.*



(6) *Bayonet.* Slip the point of the bayonet scabbard through the loop on the left side of the combat pack and attach the bayonet to the tab above. When no roll is carried, the bayonet rests flat against the side of the pack. When the roll is carried, the bayonet must be pulled from under the roll toward the soldier's back so that it is still readily available.

**e. Adjusting pack.** After the pack is completely assembled, make all adjustments so that it will rest comfortably high and flat against the back without depending on the cartridge belt to hold it in place. Adjust it, therefore, with the cartridge belt open. Use the best fitting loop running across the suspender strap; use the best fitting sets of eyelets in the front and back of the cartridge belt; adjust the length of the suspenders; and, in the double bar buckles of the suspenders, adjust the wide webbing straps that are sewed to the top of the combat pack.

**f. Stripping for combat.** To strip the pack for combat, unsnap the suspender straps from the **D**-rings on the cargo pack and pull on the double webbing loops of the four quick-release straps. Resnap the suspenders to the **D**-rings on the bottom corners of the combat pack.

**g. Carrying pack.** To rest the shoulders when you are on the march, grasp the ends of the wide webbing straps in front of the shoulders and take some of the weight on the hands. If the pack sways when the full pack is carried, the quick-release strap that rests against the back can be unfastened and slipped behind the cartridge belt and refastened.

**h. Cargo pack as furlough bag** (fig. 27). The cargo pack may also be used as a furlough bag. Attach the quick-release buckle on the front of the bag to the front metal loop under the webbing handle, the back buckle to the back loop, and the side buckles to the metal loops on the sides of the cover flap. This leaves the handle free and makes a good closure.

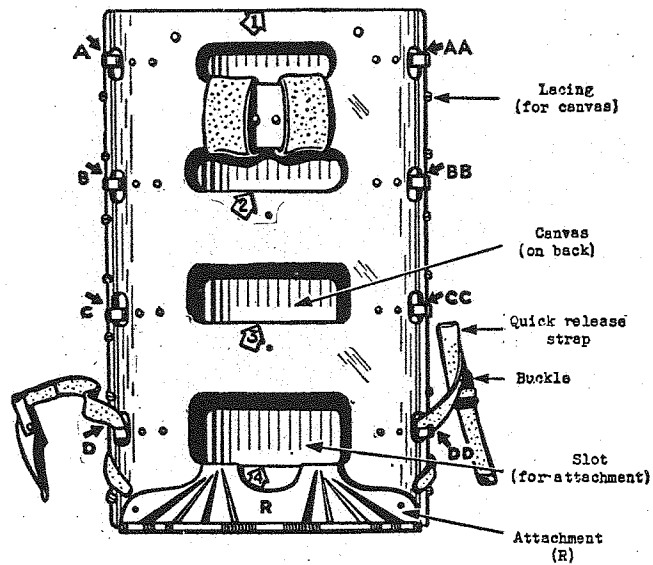


Figure 27. Cargo pack used as furlough bag.

**i. Attaching items of equipment to belt when pack is not carried.** When the pack is not carried, the canteen, the first-aid pouch, the bayonet scabbard, and the magazine pouch are carried as described in paragraph 22i.

**27. PACKBOARD (fig. 28). a. General.** The packboard, which is used for carrying loads of considerable weight or irregular shape, is a rugged frame of molded plywood, with attached shoulder straps and with canvas lashed onto the part that rests on the soldier's back. More than 100 pounds can be carried on a packboard if necessary, 50 pounds with comparative ease.

**b. Preparing packboard for use.** Tighten the lacings on the canvas before packing a load, and tighten them again whenever they become loose. To lace a plywood packboard, tie the lacing cord into one of the eyelets at the top of the canvas, and then run the cord up and around the edge of the



1, 2, 3, 4 } Point where attachments may be fastened.  
 A, B, C, D } Points where quick-release straps or ropes may be  
 AA, BB, CC, DD } attached.

Figure 28. Packboard.

packboard, back through the hole of the packboard, down along the packboard, out through the second hole, over the edge of the packboard, down through the second eyelet of the canvas, back over the edge of the packboard, through the second packboard hole, and repeat until the lacing is completed. Be sure that the edge of the canvas on each side is about  $1\frac{1}{4}$  inches from the packboard. After the first side has been laced and fastened, lace the other side as tightly as possible. If the lacing cord is twisted around a stick to form a T, it can be pulled tight without cutting the fingers. The lacings may also be tightened by placing the packboard on its edge, gradually applying gentle pressure until it is bowed

slightly, and then proceeding with the lacing. When the pressure is released, the lacings will remain taut.

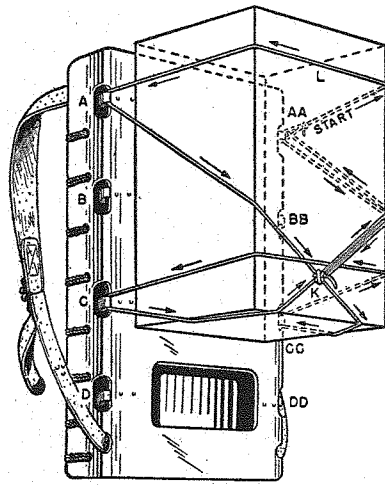
**c. Packing load.** (1) *General directions.* Objects that may be carried vary so widely that exact instructions for packing a load cannot be given. General directions, however, may be indicated. Place the board flat on the ground, if possible, with the shoulder straps down. All loads should be compact and high. Pack heavy articles as high as possible on the board, and lash lighter articles on top of them. Secure each article with either the lashing rope or the quick-release strap.

(2) *Lashing rope.* (a) *General.* Any load can be attached to the packboard with the lashing rope. The rope is better than the quick-release strap for nonrigid or irregularly shaped loads. Though methods of lashing must be varied to suit individual loads, the following procedure is applicable to all methods:

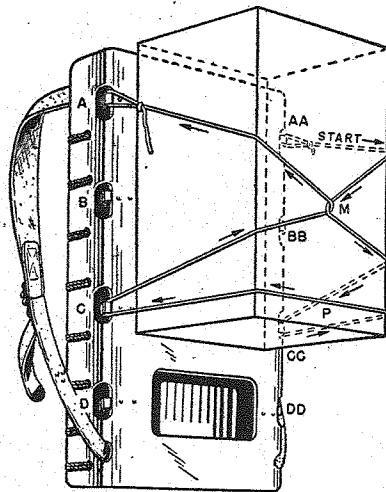
1. Tie a loop about 3 inches long on one end of the rope.
2. Use knots that will hold but can be easily untied.
3. When the lashing rope is not in use, keep it wound around the top of the packboard.

(b) *First lashing method* (fig. 29①). Hook the loop over *AA* and then run the rope across to *A*; across, downward, and under the bottom corner to *CC*; across to *C*; back to *AA* under the other bottom corner of the box; then back to *K* and tie the rope. To tighten the lashing even more, the rope may be run from the knot at *K* up under point *L*, and then brought back to *K* and knotted. Keep the lashing simple, however, and never use two loops if one is sufficient. Coil the loose end of the rope and hang it from the knot, or slip it between the plywood and the canvas.

(c) *Second lashing method* (fig. 29②). Fasten the looped rope at *AA* and loop it under *CC*, allowing sufficient slack.

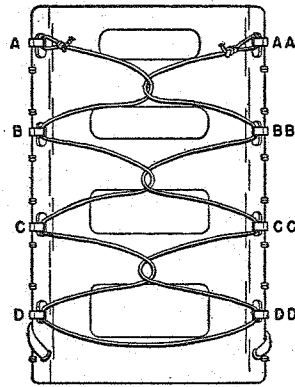


① First lashing method.

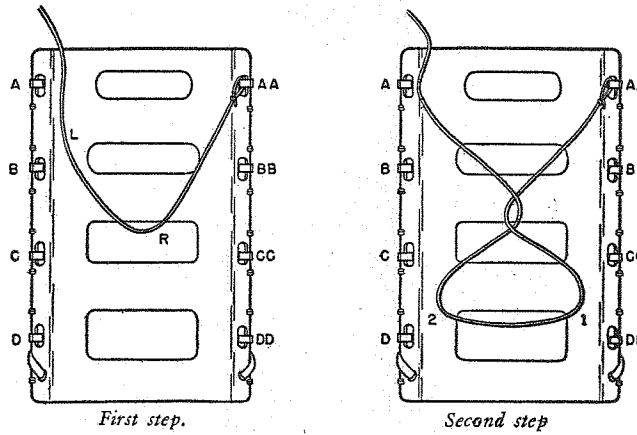


② Second lashing method.

Figure 29. Attaching loads to packboard with lashing rope.



③ Third lashing method.



First step.

Second step

④ Hints for speed in lashing.

Figure 29. Attaching loads to packboard with lashing rope (cont'd).

Loop the rope under *C*, bring it to *M*, and pull it through. If an attachment is being used, tie the rope securely at *A*. Otherwise, to keep the load from slipping down, run the rope under *P* and over to *AA* and knot it.

(d) *Third lashing method* (fig. 29③). Other methods can be worked out, such as taking the rope from *AA* to *BB* to *CC* to *DD*, etc.

(e) *Hints for speed in lashing* (fig. 29④). A load can be lashed quickly by the following methods: Hook the rope

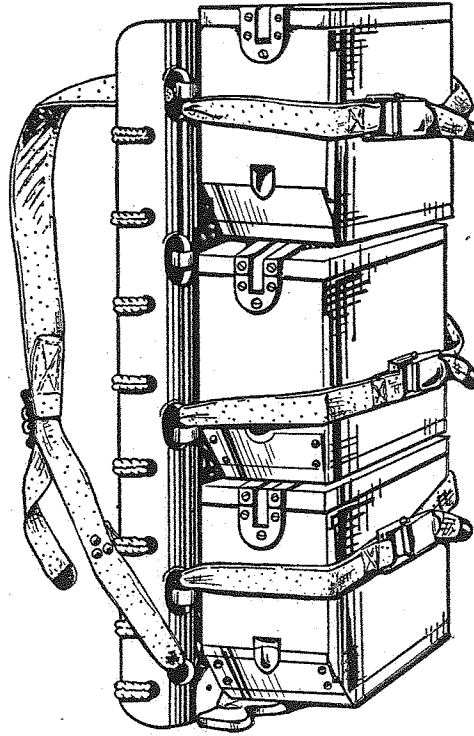
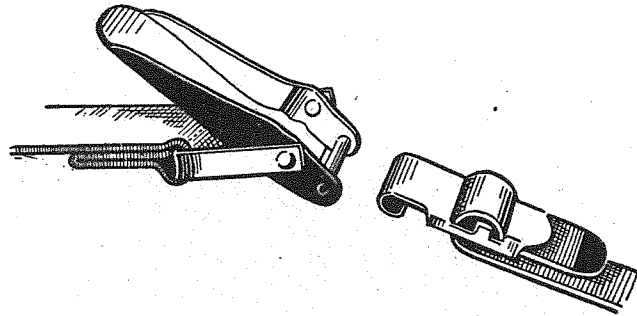


Figure 30. Regular-sized containers secured on packboard with quick-release straps.

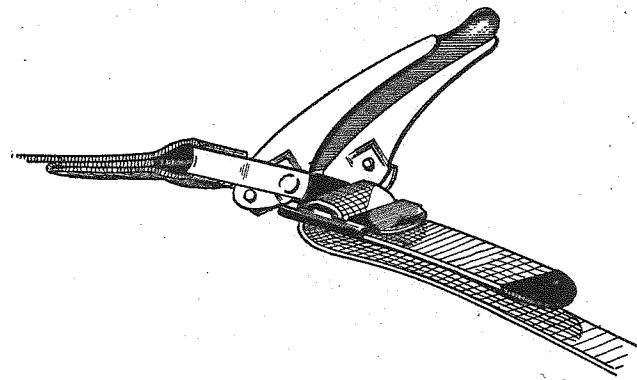
on *AA*, holding it with the right hand at *R* and the left hand at *L*. (See fig. 29④, first step.) Then twist the wrist so that the rope appears as in figure 29④, second step. Where the

rope is marked *1*, loop it over *DD*; and where it is marked *2*, loop it over *D*. Then loop it over *A* and tie it. This is a quick way to perform the second method.

(3) *Quick-release straps* (fig. 30). Quick-release straps are very helpful when the load must be packed and unpacked quickly. The number needed varies from one to three, depending on the load. Remove the buckle and slip the strap through any set of hook openings. Bring the clamp



① *First step.*



② *Second step.*

Figure 31. *Adjusting quick-release buckle strap.*



and buckle together, and place the hook of the buckle over the bar of the clamp. Take up the slack by pulling on the free end of the strap. Then throw the clamp over to secure the load. In closing the device, do not place either the clamp or buckle over a sharp corner of the load. To release, pull up on the loose end of the strap. (See fig. 31.)

(4) *Packboard attachments* (fig. 32). Packboard attachments are used both for carrying loads that rest squarely on the shelf—such as boxes, chests, 5-gallon cans, and radios—and for carrying heavy weapons. Slip the attachment flanges

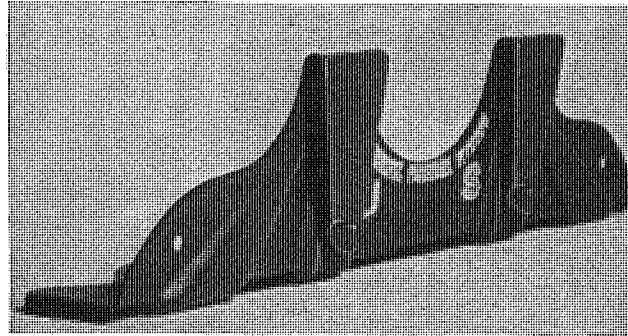


Figure 32. Packboard attachment.

over the top edge of the packboard shown as 1 in figure 28, or over the lower edge of openings shown as 2, 3, or 4 in the same figure. Do not improvise attachments. Use only those that are issued.

**d. Carrying load.** If the packboard is not heavily loaded, it may be slung onto the shoulders like any other pack. Keep the shoulder straps as short as you can with comfort, so that the load will stay high. An extra quick-release strap may be used as a belly band to keep the packboard steady. Slip the strap through the bottom hook holes or

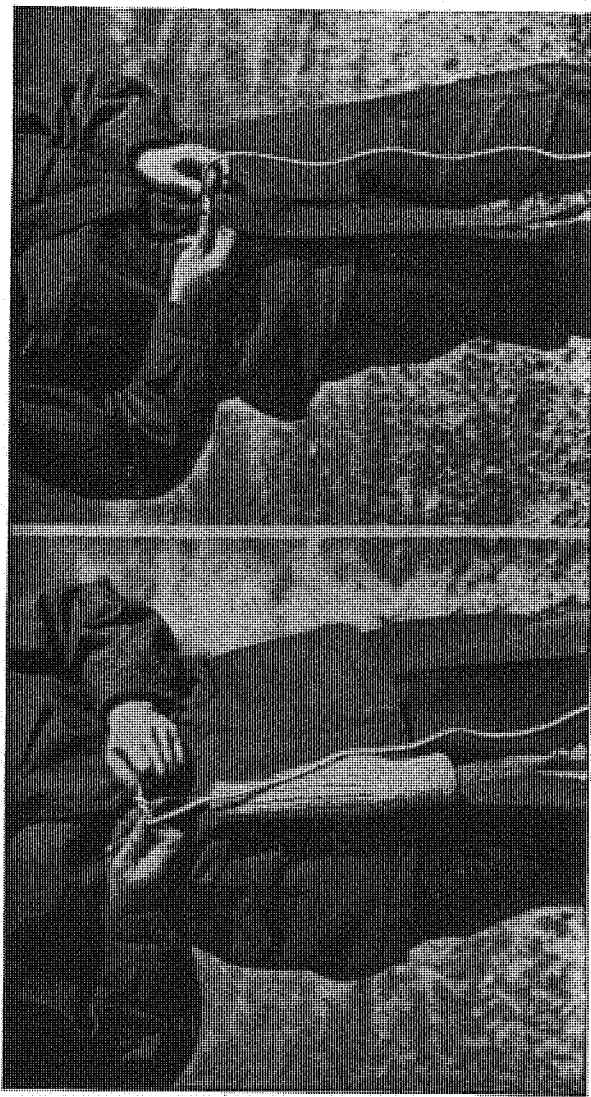
behind the canvas, and fasten it in front of the body. A cartridge belt may be converted into a belly band, but its use prevents the packboard from being removed quickly. If the shoulders become tired, grasp the lower ends of the board behind your hips and support it with your hands for a few minutes. When stopping to rest, try to find a stump or bank on which to place the load so that you can get up again without difficulty. On rough or muddy trails a staff will help prevent slipping. The following procedure is recommended if you are carrying very heavy loads that cannot be slung onto the shoulders:

- (1) Place the loaded board upright on the ground.
- (2) Sit down on the ground with your back against the canvas.
- (3) Slip your arms through the shoulder straps.
- (4) Roll over on your hands and knees and then rise to your feet.

**e. Improvising a tumpline.** (1) *General.* A tumpline is a strap that is slung from the pack over the head. It transfers some of the weight from the shoulders to the head and neck. Although tumplines are not issued, they are easily improvised from materials at hand. All that is needed is a headband with about 5 feet of rope, which can be cut from one end of the lashing rope.

(2) *Headband.* A headband may be made of a piece of webbing about 2 inches wide and 24 inches long. If only narrow webbing is available and if the steel helmet may not be worn, pad the middle part of the webbing with soft material. An old sock makes excellent padding. (See fig. 33①.) Knot the webbing at its ends, so that the rope cannot slip over it. (See fig. 33②.) The carrying strap of a canvas field bag makes an excellent headband.

(3) *Adjusting rope.* After preparing the headband, tie a 4- or 5-foot piece of rope to the webbing at one end of the



① Using an old sock for padding.

② Knotting webbing and rope.

Figure 33. Improvising a tumpline.

carrying strap. Run the rope through openings *C* and *CC* (fig. 28), and tie it to the other end of the webbing or carrier strap. (See fig. 34.) The rope should be just long enough to enable the head and neck to bear some of the weight. Experiment to find the adjustment that will best



*Figure 34. Adjusting rope of tumpline.*

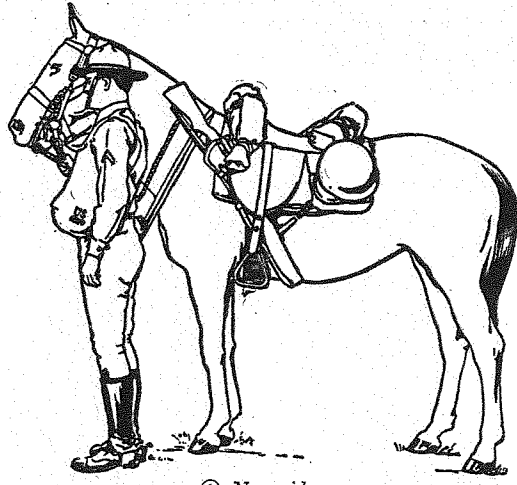
divide the weight between the shoulder straps and the tumpline. With proper adjustment, the shoulders or the neck can be rested by alternating the use of shoulder straps alone and shoulder straps with tumpline.

(4) *Use.* Run the headband across the top of the head, so that the weight bears down almost directly on the backbone.

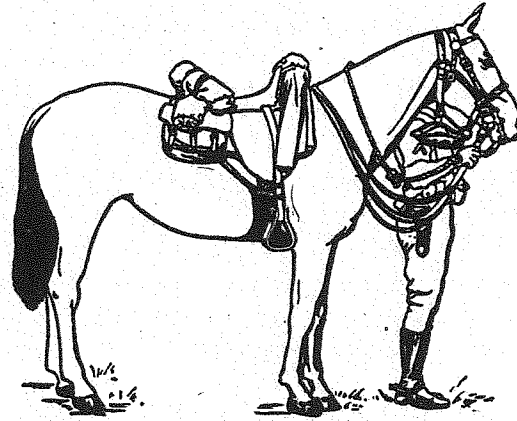


*Figure 35. Soldier carrying load with the help of a tumpline.*

If the tumpline strap is placed too far forward or too far back, it will force the neck into an unnatural, tiring position. While becoming accustomed to the tumpline and learning how to adjust it, use it for only a few minutes at a time. At first the neck and shoulder muscles may get stiff. As they strengthen, however, and you learn the best position for the tumpline, the stiffness will disappear. (See fig. 35.)



① Near side.



② Off side.

Figure 36. Pack saddle.

**f. Additional uses of packboard.** In cold, windy weather packboards can be used as windbreaks. Placed on the ground, canvas side up, they can serve as sleeping pads. Each of the new packboards will have two metal pins protruding at the top, one on each side. Rifles or other weapons may be hung on these pins.

**g. Carrying heavy weapons on packboards.** Heavy weapons can be carried on packboards with comparative ease. (See FM 23-55, 23-85, 23-90.)

**h. Care of packboard.** Mend or replace worn canvas fabric before the rips become serious. If hooks work loose, tighten them. When the fabric is soiled, wash and sun it. The back piece will need more frequent washing and sunning than the shoulder straps. Always keep the lashing cord attached to the packboard. Scrape off any caked mud that accumulates on it. Make certain that the lacings of the canvas back-section are always taut so that the plywood will not cut the back and so that air may be let in to dry the sweat. Because the canvas is necessary as a cushion, take care of it. Never drop the packboard, no matter how light the load.

**28. METHOD OF PACKING INDIVIDUAL EQUIPMENT ON HORSE (fig. 36).** **a. General.** The proper packing of saddles increases the mobility of mounted units. An even distribution of the weight prevents the backs and withers of horses from becoming sore. Loads are carried more easily when they are attached to pommels rather than to cantles.

**b. Assembling and packing cante or blanket roll (fig. 37).** Spread the shelter half on the ground, buttons up. Fold in the triangular end—or, if the new type of shelter half is used, the triangular ends. Fold the blanket through the center, bringing the ends together. Fold again, bringing the

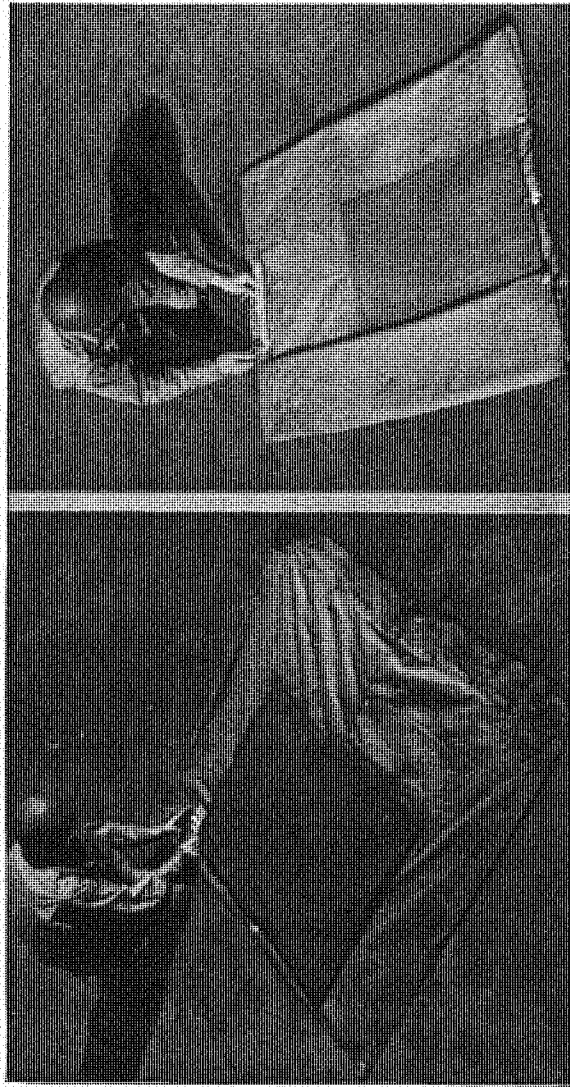
sides together. The blanket is now a rectangle, one-fourth its original size. Lay the blanket on the shelter half, equidistant from the ends and 1 inch from the side of the shelter half with the longer folded edge opposite the buttons. Place the tent pole in the double fold of the blanket so that the end of the pole is flush with the shorter folded edges. Near the loose edges of the double folds, insert the tent pins, alternating heads and points. (See fig. 37①.) The completed roll will then have a break at the center and can be fitted onto the saddle. Fold the ends of the shelter half over the blanket. To prevent the ends of the roll from pulling out, pass the free end of the tent rope several times through the tent-pin loops on the two opposite corners of the button side of the shelter half. Stretch flat and tie with a single bowknot. (See fig. 37②.) Fold back the button side of the shelter half about 6 inches to form a pocket. Then roll the entire roll tightly into the pocket. (See fig. 37③.) Break the roll to fit the cantle of the saddle. Keep the free edge of the pocket uppermost and to the rear to prevent entrance of snow, rain, or dust when the roll is on the saddle.

**c. Folding raincoat and/or overcoat.** Lay the coat on a flat surface, inside out, with collar extended. Fold lengthwise. Roll tightly from the fold toward the buttons.

**d. Attaching feed and grain bag.** Whether or not rations are carried, fasten the grain bag securely inside the feed bag.

**e. Packing saddle.** (1) Place the saddle on the ground. Fasten the saddlebags onto the cantle by means of the attachments that are provided. Strap the blanket roll to the cantle with the cantle straps, wrapping around the roll so as to use as much of the straps as possible. Buckle the straps and tuck in the loose ends. The buckles should be far enough to the rear to cause the trooper no discomfort. Press the ends of the roll forward and down toward the saddlebags. The outside





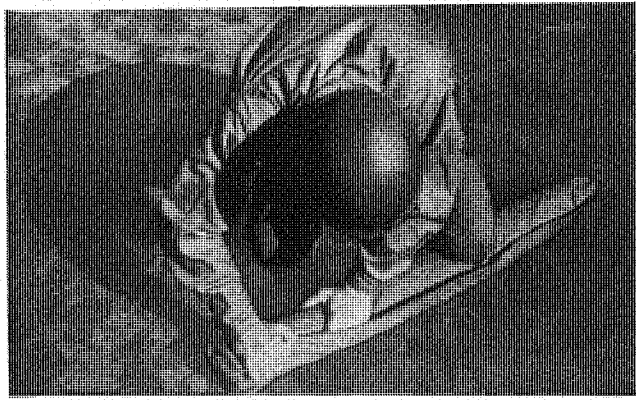
① Position of shelter half, blanket and tent pins.

② Tying corners of shelter half.

① Position of shelter half, blanket and tent pins.

② Tying corners of shelter half.

③ Assembling and packing canile or blanket roll.



③ *Completing roll.*

*Figure 37. Assembling and packing canteen or blanket roll (cont'd).*

straps should be adjusted in such a way as to keep the roll curved to the shape of the canteen.

(2) Whether or not grain is carried, strap the feed and grain bags on top of the pommel bar and tuck in the ends of the straps. Using the pommel straps, strap raincoat and/or overcoat on top of the feed and grain bag. Keep the collar to the left and the fold of the coat to the rear and down to prevent gathering dust. Press the ends of the roll toward horse's shoulders. Care should be taken to place the buckles where they will not injure the trooper.

(3) Snap the cover of the canteen and cup to the off (right) canteen ring. Buckle saddlebag-cover straps to the rear at the point where the canteen-cover straps pass under the bottom of the canteen cover.

(4) Attach the helmet, bill downward, to the near (left) saddlebag by buckling the three straps of the saddlebag flap to the chin strap of the helmet.

(5) Fasten the rifle scabbard to the near (left) side of the saddle. Attach it to the pommel ring with the upper strap

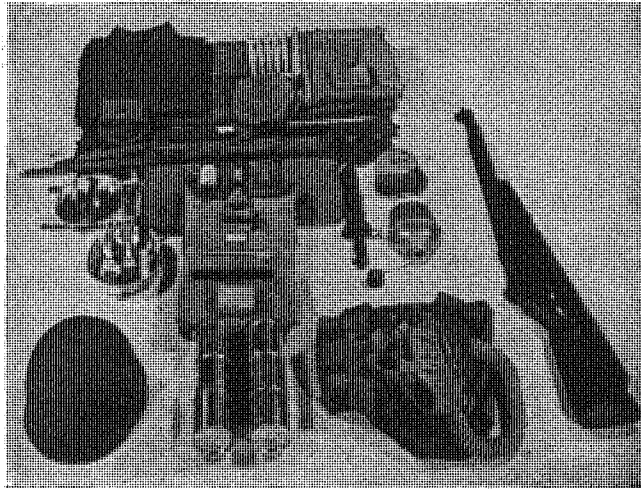
of the scabbard and to the cantle ring with the lower strap. Do not insert the rifle in the scabbard until the horse has been saddled.

(6) If possible, two men should place the loaded saddle on the horse's back. If one man must work alone, it is advisable to attach saddlebags, canteen and cup, and rifle scabbard after the horse has been saddled.

**SECTION IV**  
**DISPLAY OF BASIC EQUIPMENT**  
**FOR FORMAL INSPECTION**

---

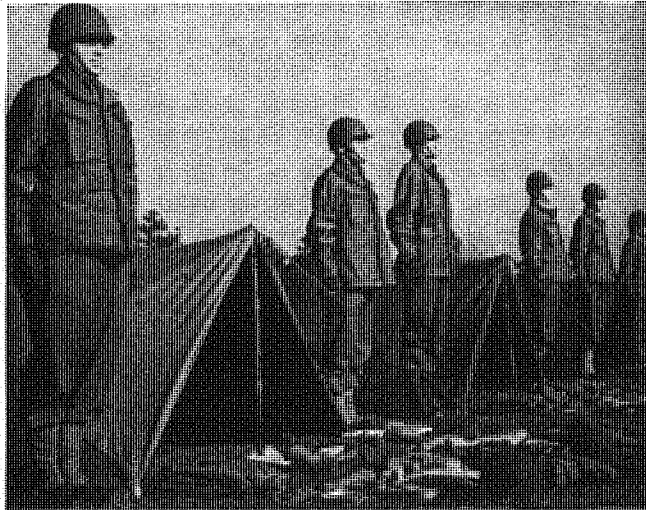
**29. ENLISTED MAN WITH HAVERSACK AND PACK CARRIER, CANVAS FIELD BAG OR RUCKSACK, JUNGLE PACK, FIELD PACK, OR CARGO AND COMBAT FIELD PACK. a. If shelter tents are**



*Figure 38. Dismounted enlisted man's basic equipment laid out for formal inspection.*

not pitched, the relative positions of basic articles of equipment are as indicated in figure 38.

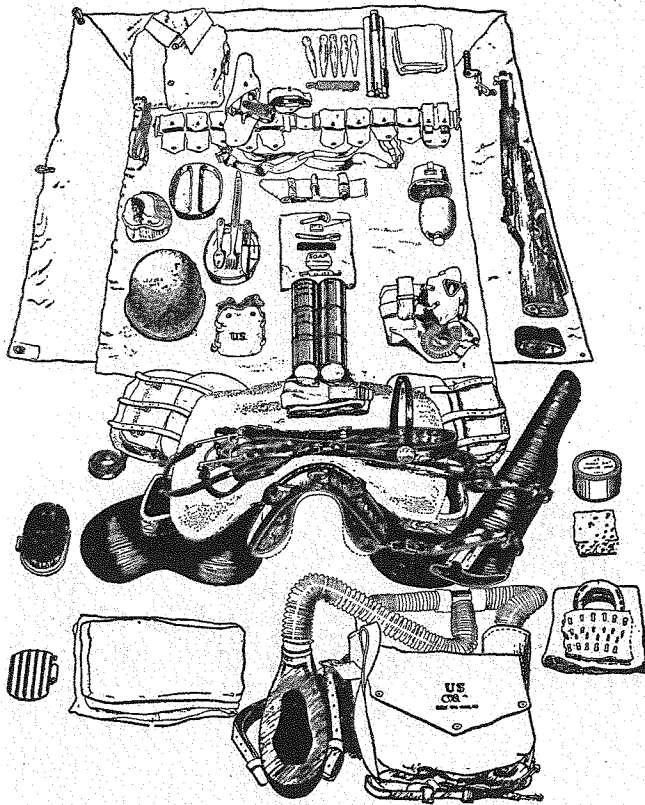
b. Special items of equipment not shown in figure 38 should be added to the display without disturbing the relative positions of basic articles.



*Figure 39. Dismounted enlisted man's basic equipment laid out for formal inspection when tents are pitched.*

c. If shelter tents are pitched, the blanket is in the position shown for the shelter half and blanket in figure 38, and the rear edge of blanket is on line with the entrance of the shelter tent. (See fig. 39.)

**30. MOUNTED ENLISTED MEN OR THOSE SIMILARLY EQUIPPED.** a. If shelter tents are not pitched, the relative positions of basic articles of equipment are as indicated in figure 40.



*Figure 40. Mounted enlisted man's basic equipment laid out for formal inspection.*

b. Special items of equipment not shown in figure 40 should be added to the display without disturbing the relative positions of basic articles.

c. If shelter tents are pitched, the blanket is in the position shown for shelter half and blanket in figure 40. Rear edge of blanket is on line with the entrance of shelter tents.

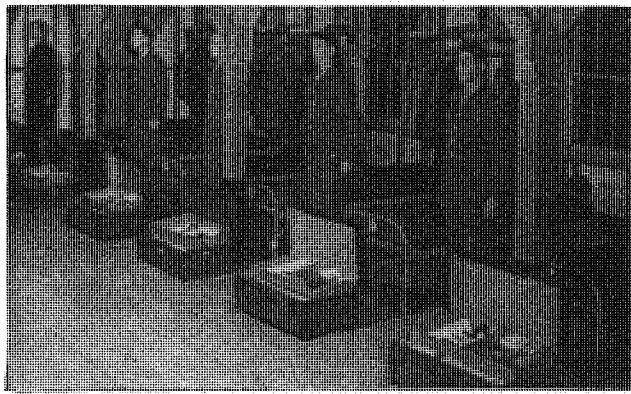


Figure 41. A typical Saturday morning inspection, showing position of the men; arrangement of foot-lockers, clothing, and footgear; arrangement and spacing of beds.

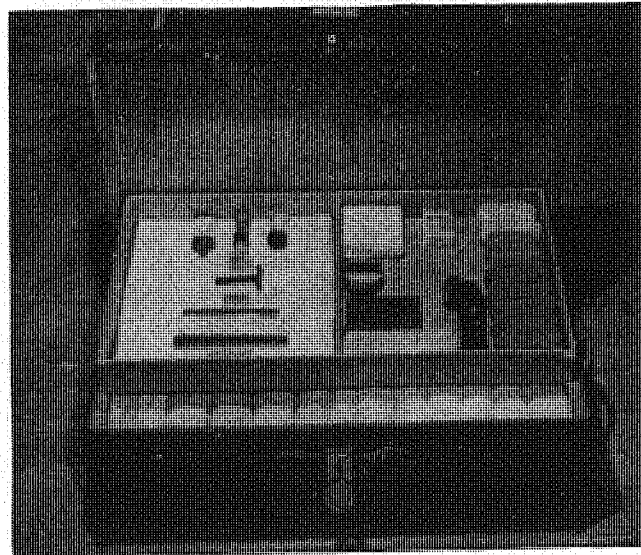


Figure 42. A foot-locker arranged for inspection, showing the location of clothing and toilet articles.

### 31. FORMAL INSPECTION IN A BARRACKS. a.

**General.** The appearance of the enlisted man, the condition and arrangement of his clothing and equipment, and the cleanliness of his barracks are principal considerations of the formal inspection. Such inspections are usually held on Saturday mornings in most posts, camps, and stations. Normally, the details of the preparation for inspection are laid down by the commanding officer. The position of the men; the position and arrangement of foot-lockers and footgear;



*Figure 43. Arrangement of clothing on hangers.*



and the arrangement and spacing of beds (fig. 41) are typical of a formal inspection.

**b. The foot-locker.** Where foot-lockers are used they will serve as the soldier's bureau and will contain clothing and personal articles currently being used. Only clean clothing will be kept in the foot-locker as dirty clothing tends to contaminate clean clothing. The lower part of the foot-locker will be used for such items as underwear, towels, trousers, and shirts. The tray will be used for smaller articles such as shaving equipment, handkerchiefs, socks, and personal items. The contents of the foot-locker will be neatly arranged at all times. (See fig. 42.)

**c. Arrangement of clothing.** The hanging of clothing on clothes hangers is beneficial as it allows the clothes to air and tends to eliminate wrinkles. For uniformity in formal inspections, like items will be grouped, and the longer items such as the raincoat and overcoat will be hung at one end, and progressively shorter items placed thereafter. (See fig. 43.)

## INDEX

|  | <i>Paragraph</i> | <i>Page</i> |
|--|------------------|-------------|
| Adjusting full equipment .....   | 21               | 21          |
| Assembling and attaching equipment .....                                   | 21-28            | 21-74       |
| Bags:  |                  |             |
| Canvas, field, od, M-1936.....   | 22               | 41          |
| Clothing, waterproof .....   | 14               | 10          |
| Duffel .....   | 20               | 20          |
| Feed and grain, attaching of .....   | 28               | 74          |
| Food, waterproof .....   | 14               | 10          |
| Sleeping, wool, and case, water-repellent .....                            | 17, 21, 25       | 18, 21, 46  |
| Bars, mosquito .....   | 18               | 19          |
| Bayonet, attaching .....   | 25               | 46          |
| Belts:   |                  |             |
| Cartridge, cal. 30, mounted M-1923, assembling Magazine, BAR, M-1937 ..... | 21               | 21          |
| Pistol or revolver, M-1936 .....   | 21               | 21          |
| Blanket roll .....   | 21               | 21          |
| Canteen:   |                  |             |
| Attaching .....  | 21               | 21          |
| Care .....   | 12               | 10          |
| Canvas, care of .....  | 9                | 9           |
| Care of:   |                  |             |
| Bag, clothing, waterproof .....  | 14               | 10          |
| Bag, food, waterproof .....  | 14               | 10          |
| Canteen .....  | 12               | 10          |
| Canvas .....   | 9                | 9           |
| Cinchas or girths .....  | 7                | 8           |
| Clothing .....   | 3                | 2           |
| Cover, protective individual .....   | 14               | 10          |

|   | <i>Paragraph</i> | <i>Page</i>   |
|---|------------------|---------------|
| Care of ( <i>cont'd</i> ):                          |                  |               |
| Helmet .....  | 3                | 2             |
| Horse covers and saddle blankets .....              | 6                | 7             |
| Knives .....  | 13               | 10            |
| Leather .....                                       | 4                | 5             |
| Mess equipment .....                                | 11               | 9             |
| Metal .....   | 5                | 7             |
| Socks .....   | 3                | 2             |
| Webbing .....                                       | 8                | 8             |
| Wood .....  | 10               | 9             |
| Carrier, pack, M-1928, attached to haversack .....  | 21               | 21            |
| Cinchas .....                                       | 7                | 8             |
| Clothing:   |                  |               |
| Care .....  | 3                | 2             |
| Cleaning .....                                      | 3                | 2             |
| Pressing .....                                      | 3                | 2             |
| Protection .....                                    | 3                | 2             |
| Repair .....  | 3                | 2             |
| Responsibility for .....                            | 2                | 1             |
| Waterproofed and water-repellent .....              | 3                | 2             |
| Cover, protective, individual .....                 | 14               | 10            |
| Display of basic equipment for formal inspection .. | 29, 30, 31       | 79,<br>80, 83 |
| Equipment:  |                  |               |
| Adjusting .....                                     | 21               | 21            |
| Care of .....                                       | 4-14             | 5-11          |
| Display of .....                                    | 29, 30, 31       | 79,<br>80, 83 |
| Individual, packing on horse .....                  | 28               | 74            |
| Mess .....  | 11               | 9             |
| Responsibility for .....                            | 2                | 1             |
| Foot-locker .....                                   | 31               | 83            |
| Haversacks, M-1928:                                 |                  |               |
| Assembling of .....                                 | 21               | 21            |
| Attaching to cartridge or magazine belt .....       | 21               | 21            |
| Attaching to pistol or revolver belt .....          | 21               | 21            |
| Packing of .....                                    | 21               | 21            |

|  | <i>Paragraph</i> | <i>Page</i>   |
|--|------------------|---------------|
| <b>Helmet:</b>   |                  |               |
| Attaching to haversack .....   | 21               | 21            |
| Care of .....  | 3                | 2             |
| Horse cover .....  | 6                | 7             |
| Inspection, field barracks .....   | 29, 30, 31       | 79,<br>80, 83 |
| <b>Knife:</b>  |                  |               |
| M-1926 .....   | 13               | 10            |
| Pocket .....   | 13               | 10            |
| Leather, care of .....   | 4                | 5             |
| Liner, helmet .....  | 3                | 2             |
| Machete .....  | 13               | 10            |
| Mask, gas, position of .....   | 21               | 21            |
| Mess equipment .....   | 11               | 9             |
| Metal parts, care of .....   | 5                | 7             |
| <b>Overcoat:</b>   |                  |               |
| Attaching to haversack .....   | 21               | 21            |
| Folding .....  | 21, 28           | 21, 74        |
| <b>Pack:</b>   |                  |               |
| Field .....  | 25               | 46            |
| Field, cargo .....   | 26               | 50            |
| Field, combat .....  | 26               | 50            |
| Jungle .....   | 24               | 46            |
| Packboard, plywood .....   | 27               | 61            |
| <b>Packing:</b>  |                  |               |
| Feed bags .....  | 28               | 74            |
| Individual equipment on horse .....  | 28               | 74            |
| Pouch, first-aid, packet, M-1942, Attaching to belt,<br>cartridge, or pistol ..... | 21               | 21            |
| <b>Raincoat:</b>   |                  |               |
| Attaching to haversack .....   | 21               | 21            |
| Attaching to bag, canvas, field, od, M-1936...                                     | 22               | 41            |
| Attaching to saddle .....  | 28               | 74            |
| Care .....   | 3                | 2             |
| Carrying .....   | 22               | 41            |

|                                       | <i>Paragraph</i> | <i>Page</i> |
|---------------------------------------|------------------|-------------|
| Rations, packing .....                | 21               | 21          |
| Roll:                                 |                  |             |
| Blanket .....                         | 21, 28           | 21, 74      |
| Horseshoe .....                       | 22, 26           | 41, 50      |
| Rucksack .....                        | 23               | 46          |
| Saddle, packing of .....              | 28               | 74          |
| Scabbard, bayonet, attaching .....    | 21               | 21          |
| Shoes .....                           | 4                | 5           |
| Socks .....                           | 3                | 2           |
| Straps, quick-release .....           | 27               | 61          |
| Suspenders, belt, M-1936 .....        | 22               | 41          |
| Tent:                                 |                  |             |
| Double shelter .....                  | 16               | 12          |
| Pitching .....                        | 16               | 12          |
| Shelter half .....                    | 16               | 12          |
| Striking .....                        | 16               | 12          |
| Tool, intrenching, attaching of ..... | 21, 25           | 21, 46      |
| Tumpline .....                        | 27               | 61          |
| Weapons, heavy, carrying of .....     | 27               | 61          |
| Webbing, care .....                   | 8                | 8           |
| Wood, care .....                      | 10               | 9           |