

# FM 12-50

WAR DEPARTMENT FIELD MANUAL

---

# THE BAND

REFERENCE USE  
ONLY

NOT TO BE TAKEN FROM LIBRARY

---

WAR DEPARTMENT • JULY 1946

WAR DEPARTMENT FIELD MANUAL  
FM 12-50

*This manual supersedes FM 28-5, 31 March 1941, including C1, 22 April 1942.*

---

THE  
BAND



WAR DEPARTMENT •

JULY 1946

---

United States Government Printing Office  
Washington : 1946

WAR DEPARTMENT  
WASHINGTON, D. C., 20 July 1946

FM 12-50, The Band, is published for the information and guidance of all concerned.

[AG 300.7 (20 Jul 45)]

BY ORDER OF THE SECRETARY OF WAR:

OFFICIAL: DWIGHT D. EISENHOWER  
EDWARD F. WITSELL *Chief of Staff*  
*Major General*  
*The Adjutant General*

DISTRIBUTION:

AAF (2); AGF (2); T (5); Dept (5); AAF Comds (5);  
Army Areas (5); Class I, II & III Instls (2); A (2); D  
(2); Hq, Continental AF (5); Organizational Bands, T/O  
& E: 20-107 (4); Separate Bands, T/O & E: 20-107 (2);  
Special distribution.

For explanation of distribution formula, see FM 21-6.

# CONTENTS

	Paragraphs	Page
<b>CHAPTER 1. GENERAL.</b>		
<i>Section I.</i> Mission and organization.....	1- 5	1
II. Equipment and general training requirements	6- 10	2
III. Personnel and duties.....	11- 26	3
<b>CHAPTER 2. TRAINING.</b>		
<i>Section I.</i> General training requirements.....	27- 32	7
II. Band rehearsal.....	33- 39	8
III. Sectional rehearsal.....	40- 41	9
IV. Music fundamentals.....	42- 46	11
V. Military training.....	47- 52	13
VI. Field music.....	53- 55	13
<b>CHAPTER 3. THE MARCHING BAND.</b>		
<i>Section I.</i> General.....	56	16
II. Marches for street and field playing.....	57- 61	16
III. Formations and movements.....	62- 74	20
IV. Positions of instruments.....	75- 94	27
V. Manual of the baton.....	95-102	60
VI. Baton signals.....	103-122	66
<b>CHAPTER 4. CEREMONIES.</b>		
<i>Section I.</i> Parades.....	123-125	78
II. Reviews.....	126-127	88
III. Presentation of decorations.....	128-129	90
IV. Escorts.....	130-134	92
V. Formal guard mount.....	135	102
VI. Religious ceremonies.....	136	106
VII. National anthem.....	137	107
<b>CHAPTER 5. THE CONCERT BAND.</b>		
<i>Section I.</i> Preparation.....	138-143	108
II. Program building.....	144-147	109
III. Mechanics of production.....	148-156	110
<b>CHAPTER 6. ORCHESTRAS AND SMALL GROUPS.</b>		
<i>Section I.</i> The dance orchestra.....	157	112
II. Small groups.....	158-162	113
<b>CHAPTER 7. THE BAND LIBRARY.</b>		
<i>Section I.</i> General.....	163-164	117
II. Procurement of music.....	165-167	117
III. Cataloging and filing.....	168-172	118
IV. Procedure of handling music in rehearsal.....	173-176	119
V. Dance orchestra library.....	177	119
<b>CHAPTER 8. GENERAL CARE OF INSTRUMENTS.</b>		
<i>Section I.</i> General.....	178	121
II. Woodwinds.....	179-186	121
III. Brass instruments.....	187-195	130
IV. Percussion instruments.....	196-197	138
V. Stringed instruments.....	198-201	141
<b>CHAPTER 9. REPAIR OF MUSICAL INSTRUMENTS.</b>		
<i>Section I.</i> Woodwinds.....	202-209	145
II. Brass.....	210-215	149
III. Percussion.....	216	152
IV. Stringed instruments.....	217-221	153

## CHAPTER 1

### GENERAL

---

#### Section I. MISSION AND ORGANIZATION

**1. SCOPE.** The procedures prescribed herein are designed for general use and may be adapted to any type of band. Some of the explanation is of a general nature which gives sufficient latitude for adaptation to specific units. Interpretation should be based on these general provisions and all should learn to use this manual as a guide to a common-sense solution of minor points which are not specifically covered in the text. Much discussion over trifles or failure to make appropriate adaptation indicates a failure to grasp the spirit of the regulations. Subordinates should be encouraged to make minor adjustments without calling on higher authority for interpretation. Necessary adaptation should be simple and should not complicate the procedures.

**2. MISSION.** Military bands provide a powerful means to commanding officers for stimulating and maintaining the morale of their units. Good bands and their smaller component parts contribute directly to the contentment and well-being of the troops by their participation in unit entertainment programs. It follows, therefore, that bands, as military units, must maintain high standards of military efficiency and that their musical performance must be characterized by its excellence, its spirit, and its versatility. Band personnel may be suitably employed in the performance of those combat duties for which their arms and training fit them. Primarily, the missions of the band are:

a. To participate in and to furnish appropriate music at military formations.

b. To furnish musical entertainment for the command as desired by the commanding officer.

c. To perform suitable combat duties as directed by the commander of the unit to which the band is organically assigned or attached. During combat the band may be employed on any of the following missions:

(1) To provide or assist in providing local security of headquarters and bivouacs. This employment includes antitank defense and defense against troops transported by air.

(2) To serve as prisoner of war escorts and to guard prisoners in unit areas.

(3) To assist the medical detachment by serving as litter bearers.

(4) To assist in handling supplies at dumps and train bivouac areas.

**3. DESIGNATION.** With the exception of "special bands," as defined in AR 250-5, all bands are organized and equipped as prescribed in T/O & E 20-107. Designation of arm or service is defined in AR 250-5. The assignment of bands to camps, posts, or installations is governed by commanding generals of the major commands in conformity with existing War Department policy.

**4. ADMINISTRATION.** The band is attached for quarters, mess, transportation, administration, and supply to a unit within the organization to which it is assigned. In all other respects the band is a separate organization. The actual training of the band, entailing rehearsals and individual instruction and practice conducted at any time of the day or evening will, by necessity, be of constant annoyance to the other troops. Where existing facilities permit, every effort should therefore be made to house the band in separate quarters.

**5. COMMAND.** The band is normally commanded by the warrant officer, band leader (AR 610-5). In the absence of a warrant officer, band leader, the commander of the installation to which the band is assigned will designate a commissioned officer, usually the adjutant of the unit or post, to act, in addition to his other duties, as commanding officer of the band.

## **Section II. EQUIPMENT AND GENERAL TRAINING REQUIREMENTS**

**6. EQUIPMENT.** Personnel of the band is armed with the carbine. Individual equipment other than arms and musical equipment is governed by T/E 21 and is the same as that of the enlisted man of the arm or service to which the band is assigned. Musical equipment and instruments are furnished in accordance with the existing Table of Organization and Equipment applicable to bands.

**7. INDIVIDUAL TRAINING.** The military training of bandsmen cannot be emphasized too strongly as the morale and functions of army bands are correlated directly with soldierly qualities and training.

o. RESPONSIBILITY FOR TRAINING. It is the responsibility of the band commander to set up and to supervise a regular and progressive program of musical and military training with particular stress being placed upon physical conditioning of all bandsmen.

**9. SPECIAL INSTRUCTION IN CEREMONIES.** In addition to the basic training of the recruit, members of the band should receive instruction in the following subjects:

- a. Ceremony of guard mounting.
- b. Ceremonies and inspections of the organization and arm of service of which the band is a part.
- c. Subjects listed in paragraph 42.

**10. MUSICAL AND MILITARY INSTRUCTION TO BE CONCURRENT.** The musical and military instruction should be given by noncommissioned officers of the band who have qualified as instructors in respective subjects. The military instruction should be given in such manner as not to interfere with the regular musical instruction of the band. The musical and military instruction of the band should be concurrent, thus enabling the bandsman at any time to put forth their best efforts in any form of duty they may be called upon to perform.

### Section III. PERSONNEL AND DUTIES

**11. PERSONNEL.** The personnel of Army bands, except for "special bands" as defined in AR 250-5, consist of such numbers and grades as are prescribed in the existing Table of Organization and Equipment applicable to organization or separate bands.

**12. ATTACHED PERSONNEL.** The appropriate commanding officer may temporarily attach a sufficient number of men to a band, as conditions may permit, so that the authorized instrumentation is secure and so that qualified personnel may be available to make up for losses by sickness, transfer, and discharge. It is desired, however, that these attachments be held to a **minimum**.

**13. QUALIFICATION OF BANDSMEN.** All bandsmen must qualify and maintain a minimum standard of musical proficiency on their major instruments as outlined in this manual and should add performance ability on other instruments in order to insure the versatility of the band.

**14. BAND LEADER.** a. As band leader, the warrant officer is re-

personally supervise the musical instruction of the bandsmen and may detail qualified noncommissioned officers to act as his assistants. He will normally conduct all concerts and will attend all drills, parades, and such other ceremonies as may require the presence of the band. He will submit weekly schedules of musical duties to his immediate commanding officer and will be held responsible for strict compliance with such schedules when approved. The band leader will inspect all musical instruments at least once a week. When buglers are used on the installation to which the band is assigned, the band leader will be responsible for their training and will request proper authority to detail a qualified noncommissioned officer, other than a bandsman, as sergeant bugler.

b. As commanding officer of the band the warrant officer band leader is responsible for the military training and discipline of the band. He will be held responsible and accountable for all musical instruments whether issued by the quartermaster or purchased through nonappropriated funds.

**15. ASSISTANT BAND LEADER.** The technical sergeant, assistant band leader, is the band leader's musical executive and understudy and represents him in his absence. The assistant band leader will perform the duties of first sergeant of the band. In the absence of the band leader, the assistant band leader will perform the former's musical duties, and the next senior noncommissioned officer will act as first sergeant.

**16. STAFF SERGEANT.** The staff sergeant may in addition to his musical duties be detailed as orchestra leader and as an understudy to the first sergeant. This arrangement will afford the staff sergeant an opportunity to familiarize himself with the duties of a first sergeant.

**17. BAND SERGEANTS AND CORPORALS.** Band sergeants and corporals (technicians, 4th and 5th grades) should be men of excellent soldierly qualities, competent instrumentalists on their major instrument, and outstanding in respect to specific military and musical duties.

**18. SUPPLY SERGEANT.** The musician designated by the band leader as supply sergeant will keep account of all property, such as musical instruments, cases, music stands, etc., and will insure that supplies issued are properly charged and will maintain reserve stocks in the storeroom in good condition.



**19. INSTRUMENT REPAIR MAN.** The repair man will be responsible for the first and second echelon repair and maintenance of all instruments and musical property. (See pars. 202 to 221 incl.) He will check at regular intervals all instruments and supplies not in use. Under direction of the band leader he will instruct band members in the care and maintenance of instruments.

**20. MUSIC LIBRARIAN.** The musician designated by the band leader as librarian will be responsible for all music contained in the band, orchestra, and dance band library. He will list and index all music in the library and maintain a library of musical manuals, books, etc., which will be available to the bandsmen for reference and study. He will assist the band leader in the requisitioning or purchasing of music, and will maintain all necessary records of the music and materials in the library.

**21. DRUM MAJOR.** The drum major will be selected by the band leader for his soldierly appearance, knowledge of band formations and ceremonies, skill in the manual of the baton and in the execution of baton signals.

**22. SPECIFIC FUNCTIONS OF DRUM MAJOR.** Under the command of the band leader the drum major acts as a guide for the band under all conditions where verbal commands cannot be heard. It is essential that more than one man be trained to act as drum major.

**23. DISTRIBUTION OF GRADES AND RATINGS.** Bandsmen may be given grades in accordance with their soldierly qualities and musical proficiency within the limitations of appropriate tables of organization. The higher grades should go to the more competent musicians and soldiers who are qualified to discharge properly the normal duties of noncommissioned officers. All forms of military and musical leadership, including ability to direct small groups, as well as skill on major and minor instruments, should be given due consideration in the assignment of grades.

**24. FURLOUGHS.** To permit the best possible over-all use of the band the blanket furlough policy should be adopted. Under this policy the entire band is absent from duty for the furlough period and is not seriously crippled over an extended period of time when a number of men are absent in recurring periods.

**25. COORDINATION OF FURLOUGH POLICY.** The policy discussed

in paragraph 24 can be successfully accomplished with the provision of AR 615-275 through close coordination between the band leader and the installation commander.

**26. COMPENSATING TIME OFF FOR NIGHT PLAYING.** When prescribed duties entail a considerable amount of night playing while the rest of the troops are off duty, the training schedule should be arranged to allow compensation of time off for rest and recreation.

## CHAPTER 2

### TRAINING

---

#### Section I. GENERAL TRAINING REQUIREMENTS

**27. GENERAL.** Technical training prepares the band to perform its musical duties. These duties include ceremonies, concerts, dances, and all other engagements which employ musical facilities. Excellence in performance of these duties as a band depends directly upon the proficiency of the individual player.

**28. PREREQUISITES FOR BANDSMEN.** As a prerequisite for assignment to an Army band, an enlisted man should possess the following qualifications in theory:

- a. Knowledge of major and minor scales and key signatures.
- b. Intervals in all keys.
- c. Familiarity with treble and bass clefs.
- d. Fundamentals of musical notation and terminology.

**29. PLAYING REQUIREMENTS.** The bandsman will, in addition, meet the following playing requirements:

- a. Playing of all major and minor scales, intervals, arpeggios throughout the practical range of his major instrument at the speed of MM = 120 ( $\frac{1}{4}$  note).
- b. Production of full, rich, characteristic tone throughout instrument's range.
- c. Articulations practicable on the instrument, single, double, or triple tonguing.
- d. Lip slurs in harmonic series.
- e. All transpositions normally required of the instrument.
- f. Ability to play characteristic solo passages for the instrument as found in standard band literature with proper observance of phrasing, dynamics, breathing, and interpretation.

**30. SEMISKILLED PLAYERS ASSIGNED TO BAND.** When a sufficient number of skilled musicians are not available, semiskilled players may be accepted for training by the band leader. Such players should be required to complete, in the shortest time, a course of instruction in order to meet the requirements outlined in para-

graph 29. Following are minimum standards which should govern acceptance of such players :

- a. Qualifications listed in paragraph 28.
- b. Ability to play correctly all simple rhythm figures.
- c. Ability to play correctly marches of ordinary street grade.

**31. PLAYERS DOUBLING ON SEVERAL INSTRUMENTS.** All players doubling on several instruments should improve their technique on the minor instruments as rapidly as the time required on their major instruments will permit.

**32. INDIVIDUAL PRACTICE.** Supervised individual practice in daily periods is strongly advised. Such a period the first hour of the training day prepares the lips well for the full band rehearsal to follow and allows the individual to perfect difficult passages and to develop his technique.

## **SECTION II. BAND REHEARSAL**

**33. QUARTERS.** The quarters selected for training the band should be equipped with the necessary facilities for the proper conducting of rehearsals. In addition to being large enough to seat the organization comfortably, the room must possess acoustic qualities which will make possible an undistorted blending of musical sounds. A well-tuned piano or organ, blackboard, chalk, eraser, podium, metronome, and a phonograph are necessary. Heating and lighting must be checked before the rehearsal begins. Routine adjustments such as arrangements of chairs and stands should be made beforehand. Music to be rehearsed should be listed in proper order on the blackboard.

**34. TECHNICAL POINTS TO BE STRESSED.** The following points should be kept in mind and stressed at every band rehearsal: Intonation, balance, technique, phrasing, articulation, rhythm, style, tone quality, posture, breath control, flexibility in following the conductor, dynamics, sight reading, and transposition.

**35. ARRANGEMENT OF MUSIC TO BE REHEARSED.** Upon taking his place, each bandsman arranges the music in his folder to correspond with the order listed on the blackboard. Much time is lost when the band leader has to announce the next number to be studied, and then has to wait for bandsmen to leaf through the folders to find it. It is important that all rehearsals begin and end on time.

**36. WARMING-UP EXERCISES.** It is advisable to begin all band rehearsals with the playing of chorales or sustained exercises. This long tone playing is an excellent means of warming up and may serve as a study in intonation. Playing a heavy march before the lips are properly warmed up is detrimental to the brass players. The proper time to attempt accurate tuning should be at the completion of this "warming-up" period, as by this time the instruments will have been brought up to their proper pitch. Upon completion of this preliminary phase, both the lips and instruments are warmed to the point where accurate tuning is possible.

**37. SUGGESTED ARRANGEMENT OF REHEARSAL PERIOD.** Rehearsal should be made as varied and interesting as possible. Following is a suggested arrangement for the entire rehearsal period:

- a. Chorale, warm-up, 2-5 minutes.
- b. Technique exercises, scales, tuning, 5-10 minutes.
- c. Work on partially prepared numbers, 20-40 minutes.
- d. Reading new numbers, 15-25 minutes.
- e. Rhythm drill, applied theory problems, 15 minutes.
- f. Final polish on numbers for presentation, 15 minutes.
- g. Close with a thoroughly familiar number.

**38. REHEARSAL DISCIPLINE.** Discipline is as important a factor in the conduct of a good rehearsal as the music played. Proper posture, undivided attention to the conductor, position of instruments while playing and at rest, and no unnecessary talking or playing all combine to produce satisfactory results. During breaks or rest periods, bandsmen should not play their instruments. Instrument cases should be left at a designated place at one side of the room so that they will not interfere with the band set up.

**39. LIBRARIAN TO PREPARE MUSIC FOLDERS.** It is the duty of the band librarian to have the folders ready for each rehearsal. When sorting racks are used in the band room, prepared folders will be ready for the players as they come to each rehearsal. At the end of the rehearsal the individual bandsmen return their folders to their proper places in the sorting rack. Collecting or passing out music during rehearsal is a waste of time and an indication of poor management.

### Section III. SECTIONAL REHEARSAL

**40. RESPONSIBILITY AND PURPOSE.** Section leaders are responsible for the musical performance of their respective groups and

will conduct separate rehearsals when necessary. (See fig 1.) Frequently an entire section, the clarinets for example, may have difficulty with some particular parts of a composition. In order to avoid undue loss of time at rehearsals and to maintain the interest of all players present, a frequent period of sectional practice should be held for each section of the band, at which time pas-

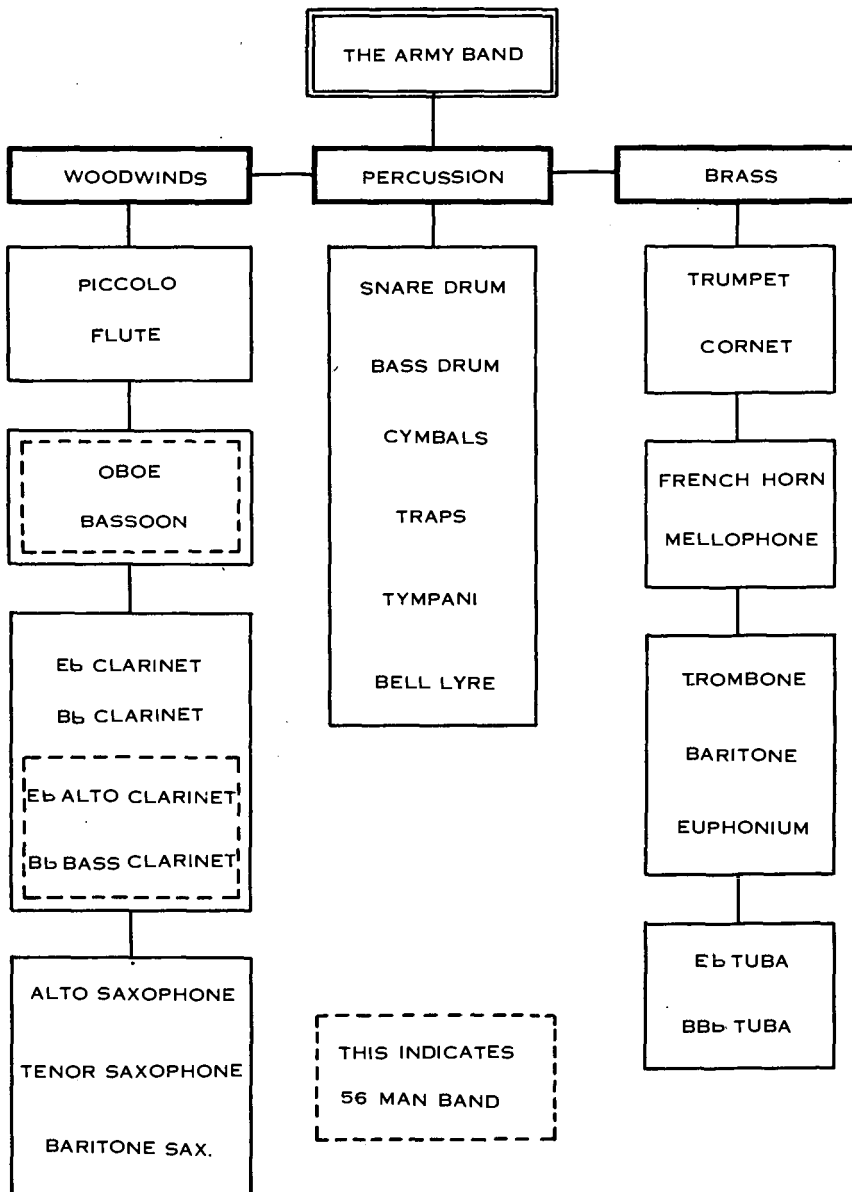


FIGURE 1. SECTIONS OF THE BAND.

sages which have been found to be difficult for that particular section should be analyzed, explained, and practiced. The difficulty generally can be overcome by the simple expedient of having the section concerned play the difficult passage at a very slow tempo, eventually increasing the speed by degree as the players become more and more familiar with the problem presented.

**41. MIXED SECTIONS.** Interest may be added to sectional rehearsals by occasionally mixing small groups of reed and brass instruments, the instrumentation of which should be varied from time to time. Section practice of this kind, conscientiously followed, will bring about a unity not to be obtained in any other way as minor discrepancies which can be heard in small groups may easily escape detection when the full band is playing. The regular elimination of small but numerous rough places, section by section, will be reflected eventually in the smoothness and precision of the band as a whole.

#### Section IV. MUSIC FUNDAMENTALS

**42. GENERAL.** A thorough knowledge of music fundamentals is necessary for the bandsman to make an intelligent and accurate reading of the musical page. Classes in theory, notation, and rhythmic should be held regularly for the constant improvement of the musicianship of the bandsman and the general efficiency of the band as a whole. The course may be divided into four main groups: Notation; rhythm; pitch; and theory. Instruction in all four branches may be presented concurrently. Presentation of points outlined below will be made as problems occur in actual practice.

**43. NOTATION.** a. Special attention should be given to the use and meaning of the different signs, marks of expression and dynamics, abbreviations, etc., including the study of notes, rests, and the different kinds of clefs and their use. The bandsman often is required to transpose, specifically in case of:

- (1) Breakdown of the band into smaller groups or components.
- (2) Playing from song books.
- (3) Performance of a piece of music not originally composed for band.
- (4) Missing parts.
- (5) Unusual instrumentation.

b. The bandsman also will be expected to know and be able to illustrate all the commonly used musical terms.

**44. RHYTHM.** For developing the players' rhythmic sense, exercise in clapping or tapping basic and compound figures is recommended. Various intricate rhythms should be broken down into minute subdivisions so that players may grasp fully the exact structure of the figures and not merely approximate them in playing. The metronome should be demonstrated and used regularly for the proper study of tempo.

**45. PITCH DISCRIMINATION.** Determination of pitch depends upon the acuteness of the sense of hearing to recognize and distinguish the vibrations of sounds and is the result of ear training. Melodic dictation, the writing down of melodies while they are played, develops a coordination of ear and eye which is highly desirable. Exercises of this type may be varied from week to week with sight-singing of easy but unfamiliar tunes both in unison and in three and four part harmony, starting with simple melodies and gradually progressing to the more difficult. Occasional periods should be devoted to actual tests of pitch discrimination. For this purpose the student will be required to name intervals and chords when played on the piano. By regular practice a player with only an average ear for intonation can improve accuracy of pitch in his individual playing.

**46. THEORY.** a. The study of theory must begin with the structure of scales. The bandsman should be able to construct all major and minor scales from any given note.

b. The player should be proficient in naming, writing, and singing all intervals and should understand their inversions. Only after he has mastered intervals may he proceed to the study of chords.

c. The bandsman should understand thoroughly all kinds of triads. He should understand triad inversions and simple progressions.

d. Some form analysis may be studied using the music being rehearsed for future performances.

e. Playing in trios, quartets, and other small ensembles is a valuable means of developing individual proficiency and self-assurance. Regular weekly periods should be set aside for this type of activity if at all possible.

f. Bandsmen with excellent musical background should be encouraged to further study in harmony and arranging. The band leader should assist such men in preparing arrangements for the concert band, dance orchestra, and small combinations. Deserving works may be played, and strong and weak points noted. Outstanding numbers should be given a place on public programs.



## Section V. MILITARY TRAINING

**47. GENERAL.** Particular stress should be placed on the military qualifications of those bandsmen chosen to become noncommissioned officers, as it will be one of their prime duties to assist the band leader in the military training of the band. Emphasis will be given to those subjects essential to efficient performance of field duties by Army bandsmen, that is, map reading, individual security, guard duty, personal hygiene, first aid, and chemical warfare.

**48. RESPONSIBILITY OF BAND LEADER.** It is the responsibility of the band leader to set up a program of military training to be carried on in addition to the musical training and the normal musical duties of the band.

**49. SMALL ARMS.** A thorough knowledge of nomenclature, care, and use of "small arms" as directed, is expected of all bandsmen. Regular review periods will be conducted to insure proficiency. Use of bandsmen as security detachments under varying circumstances necessitates a knowledge of these weapons.

**50. MARCHES AND BIVOUACS.** Marches and occasional bivouacs are incorporated into the military training to serve both as a physical conditioner for the men and as an opportunity to review and extend the bandsmen's knowledge of map reading and chemical warfare defense.

**51. PHYSICAL CONDITIONING.** Daily periods of physical conditioning will be scheduled. These periods may include calisthenics, massed games, or any other effective means of physical conditioning that the band leader may schedule.

**52. TRAINING AS MESSENGERS.** A thorough knowledge of the organization of the Army is essential for bandsmen in order that they may act efficiently as messengers and dispatch runners under field conditions. Particular stress will be placed on divisional organization, as bands may act in connection with division message centers.

## Section VI. FIELD MUSIC

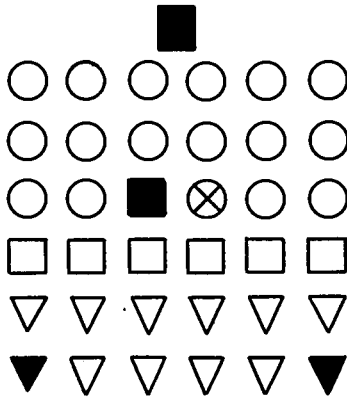
**53. ORGANIZATION.** The field music consists of all the trumpeters of an organization when assembled as a unit. It renders honors, substitutes for the band, and in organizations with bands, it may play with the band or may take turns with the band in

playing. Well-drilled field music, playing with precision and spirit, is a stimulus to morale. When trumpeters are required to march or play with the band as at parades and reviews, they will take position in rear of the band. Trumpet parts of band marches occur, as a rule, in the trio; they are written for the F and B $\flat$  bugle, the B $\flat$  bugle (clarion) having a brilliancy more suitable for military music. The band leader will attend to the tuning of the field music with the band. Signals to begin and cease playing are given by the chief trumpeter. When the trumpeters are required to play continuously for several minutes, the trumpet section should be divided into halves to play alternately in order to afford short rests for each trumpeter. The instrumental ratio should be approximately two trumpeters to one snare drum, or three fifes to one drum. Field music, when acting as a separate unit, should have a drum major, one bass drummer, and one cymbal player.

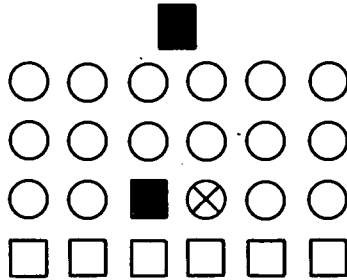
**54. EQUIPMENT.** The field musician's equipment includes such instruments as are listed in TM 20-250. The B $\flat$  bugle (clarion) mentioned in paragraph 53 may be purchased from nonappropriated welfare funds under the provisions of AR 210-50.

**55. MARCHING FORMATION.** When the field music is to take the place of a band, it will be formed as shown in figure 2. Whenever the field music marches with the band it will be formed in the rear of the band. The line-up of the field music will conform with the number of files in the band. If local conditions permit, it is suggested that members of the field music be attached to the band for training, as this will insure a high standard of performance by the field music.

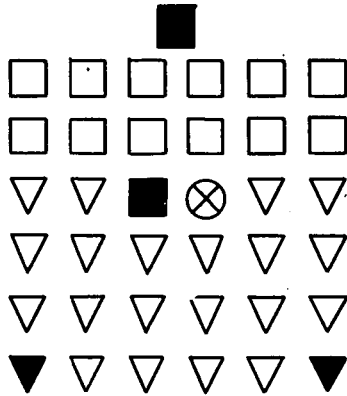
FIELD MUSIC - COMPOSED  
OF FIFERS DRUMMERS  
AND TRUMPETERS




FIELD MUSIC - COMPOSED  
OF FIFERS AND DRUMMERS



FIELD MUSIC - COMPOSED  
OF DRUMMERS AND  
TRUMPETERS



LEGEND

SNARE DRUMMER  DRUM MAJOR  BASS DRUMMER 

BASS TRUMPETER  TRUMPETER  FIFER  CYMBAL PLAYER 

NOTE: INTERVALS AND DISTANCES 2 PACES

FIGURE 2. SUGGESTED FORMATIONS FOR FIELD MUSIC.

## CHAPTER 3

### THE MARCHING BAND

---

#### Section I. GENERAL

**56. FUNCTION.** a. Military bands are complete musical marching units which provide music for all military ceremonies and troop marching requirements.

b. The band, in addition to being a thoroughly trained musical organization, must be a well drilled military unit on the field. The function of band drill is to train the soldier-musician to fit into a marching unit both in a military and a musical manner. Band drill which is given in a systematic and sequential order will train the bandsman to function as an integral part of a military band of any size. This training can be brought to a successful conclusion only by thorough, constant, and concentrated drill. Precision in all band drill details is essential in a fine marching band.

c. The band in the field entertains troops and affords music for all military ceremonies. It must be able to march in parades and to take part in retreat ceremonies, reviews, guard mounts, or any combination of these ceremonies. Without music these military functions would be lifeless. The provision of music of the highest quality is imperative in these ceremonies. The band drill regulations given in this section of the manual are designed for, and may be adapted to, any size military band.

#### Section II. MARCHES FOR STREET AND FIELD PLAYING

**57. REPERTOIRE.** The band must have in its repertoire a variety of marches for various occasions. Care should be taken in choosing the most suitable march for each function. Marches generally may be classified as concert and street marches. Those which are good for one purpose may be ill-suited to the other because of tempo and style.

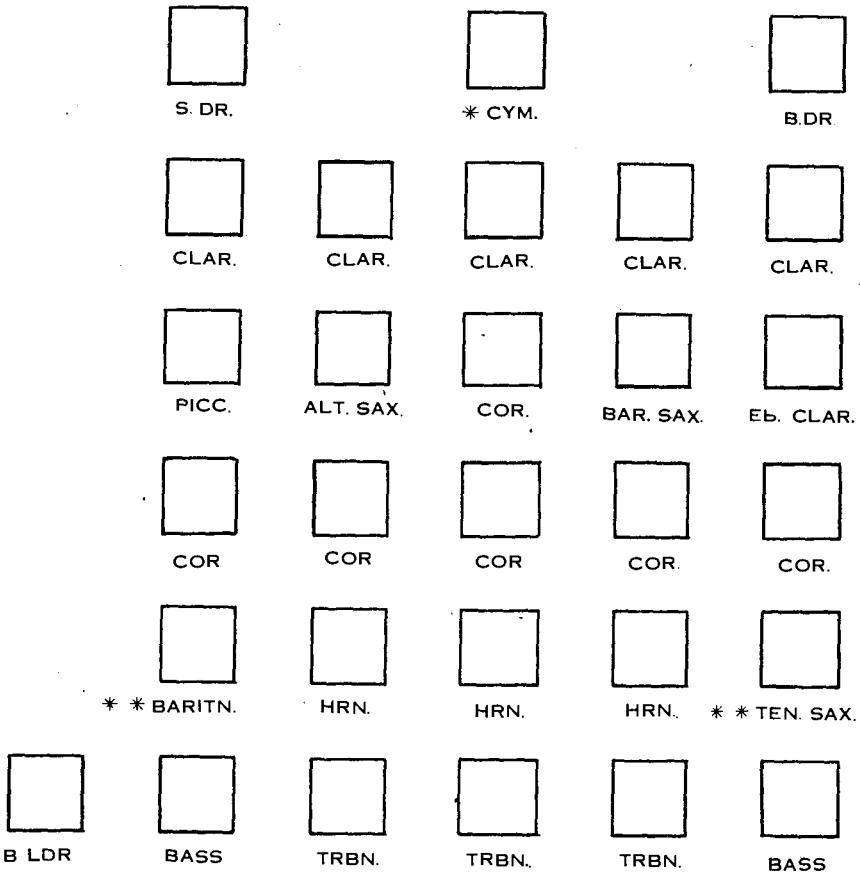
**58. STREET AND PARADE MARCHES.** Street marches should be simple, rhythmically and melodically strong, of not too extreme a range, and of a character that sounds effective at marching cadence. The arrangement should be of a type that will sound rich and full without unduly tiring the lips of the bandsmen.

Melody, counter-melody, and rhythm should be well defined with a well distributed instrumentation.

**59. COMMITTING MARCHES TO MEMORY.** Marches for parade purposes should be well known to all performers. Simplicity and directness are two very desirable qualities in all street marches. It is suggested that bandsmen be required to memorize a few good street marches for use during military ceremonies. This will enable the individual bandsman to pay more attention to the exact alignment.

**60. ALTERNATING WITHIN SECTIONS.** The instrumentation should be arranged to allow for various sections to rest so that the entire band is not playing constantly. Marches may be varied and made effective by allowing various sections to play prominent parts while the rest of the band remains silent. Field marches should be rehearsed at the tempo at which they are to be played, so that the band accustoms itself to maintaining a definite, strict, and constant tempo without temptation to rush or drag. When alternating within sections all players should play all introductions, interludes (breaks), and endings.

**61. SUGGESTED MARCHING FORMATIONS.** Figures 3 and 4 illustrate the most effective marching formation both in regards to balance and appearance.



\* ONE CLARINET SHOULD BE SPARED FOR PARADES IN ORDER TO PLAY CYMBALS

\*\* BARITONE EUPHONIUM AND TENOR SAX. INTERCHANGEABLE ACCORDING TO POSITION BARITONE PLAYER HOLDS INSTRUMENT BELL OF INSTRUMENT SHOULD POINT TO INSIDE OF BAND.

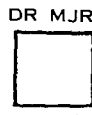
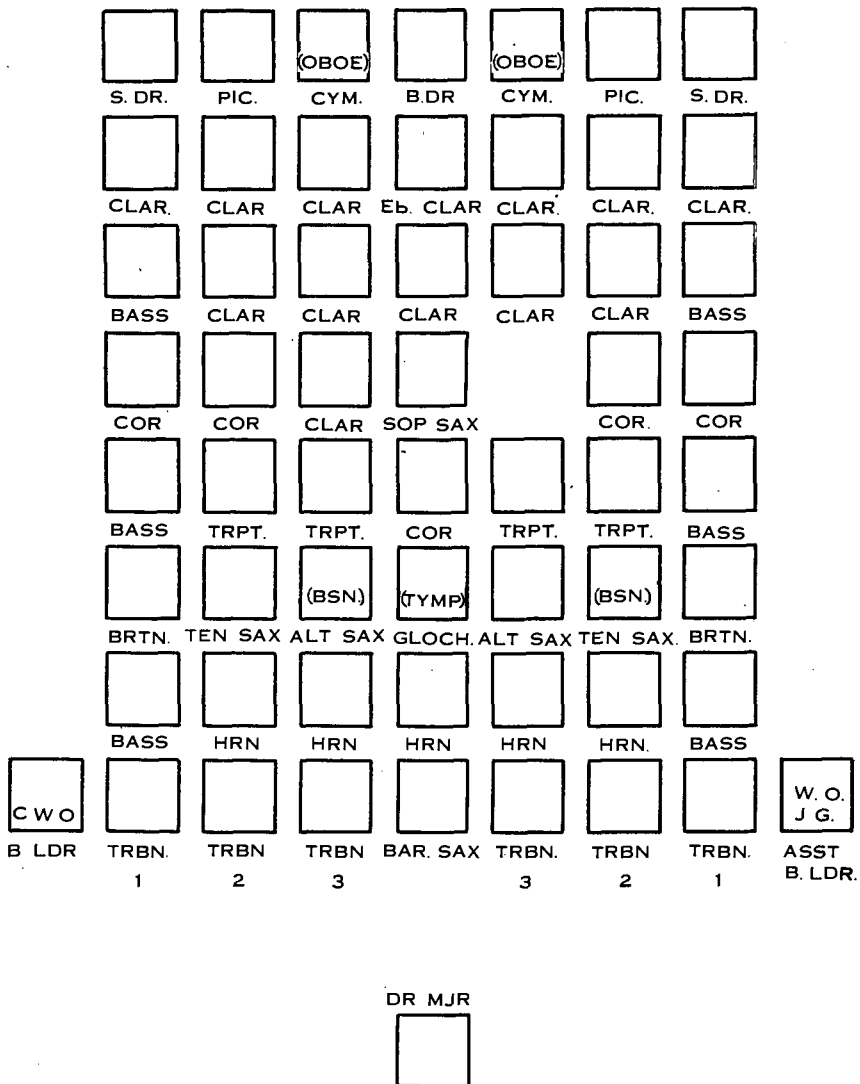


FIGURE 3. RECOMMENDED MARCHING FORMATION, 28-PIECE BAND.



NOTE: INSTRUMENTS IN PARENTHESIS ARE DOUBLES FOR CONCERT

FIGURE 4. RECOMMENDED MARCHING FORMATION, 56-PIECE BAND.

### Section III. FORMATIONS AND MOVEMENTS

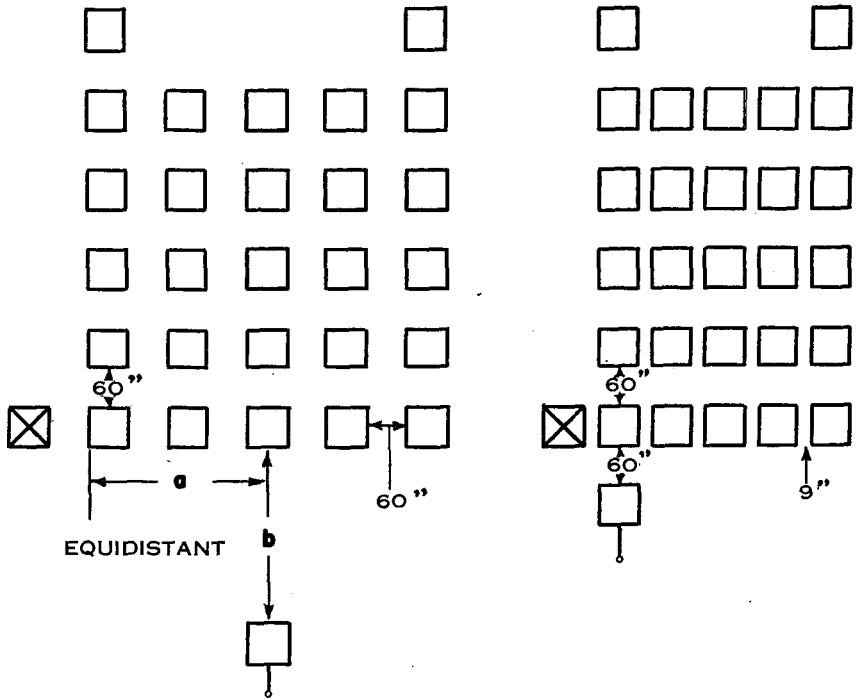
**62. PLAYING FORMATION.** The band ordinarily forms in playing formation. The position of the drum major is the same number of paces in front of the first rank as the number of paces from the center of the first rank to either flank. (See fig. 5.) From this position the drum major gives the command: FALL IN.

**63. INTERVAL AND DISTANCE.** In playing formation both interval and distance are 60 inches. The drum major checks alignment, returns to his position facing the band leader and, after saluting, gives the report.

**64. CLOSE FORMATION.** When it is desired that the band fall in in close formation, the command is: 1. AT CLOSE INTERVAL. 2. FALL IN. The man in the center file of the front rank takes his position 60 inches in front of and facing the drum major. The band falls in with an interval of 9 inches between files and a distance of 60 inches between ranks. After checking alignment, the drum major takes a position as right guide. (See fig. 6.)

**65. GUIDE.** When marching in playing formation the center file is the guide in bands using an odd number of files. The right center file is the guide in bands using an even number of files.





LEGEND

- MUSICIAN
- DRUM MAJOR  
↓
- ⊗ BAND LEADER

FIGURE 5. PLAYING FORMATION.      FIGURE 6. CLOSE FORMATION.

**66. RIGHT (LEFT), TURN.** The pivot steps off 2 paces in the new direction then proceeds at a half step. Remaining members of the first rank execute two obliques to assume the new direction of march at the proper interval. Each man takes the half step on arriving abreast of the pivot man. Each rank executes the movement in like manner as it reaches the point where the first rank began the change of direction. When the entire band has completed the change, drum major signals: FORWARD, MARCH.

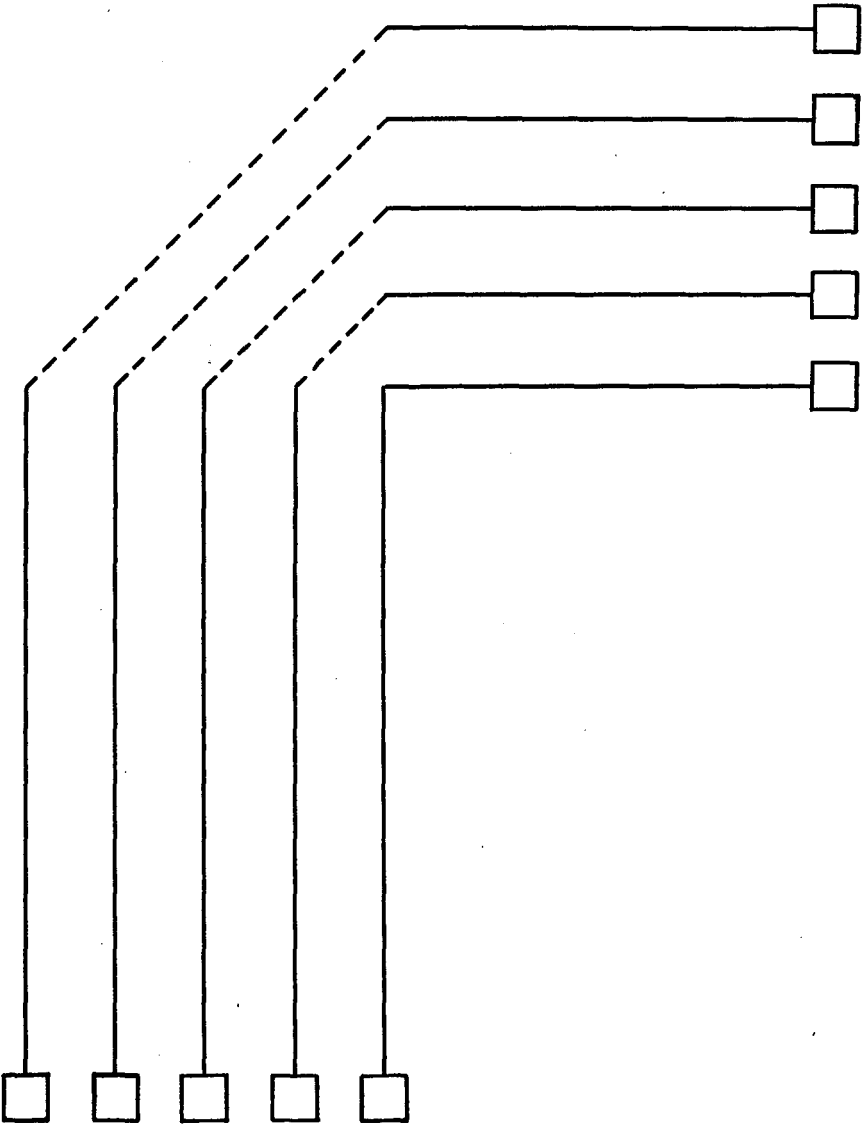


FIGURE 7. RIGHT (LEFT) TURN.

(See fig. 7.) On a right turn the command of execution is given as the right foot strikes the ground. The command is given on the left foot in executing a left turn.

**67. DRESSING ON PIVOT.** On all changes of direction, each rank dresses on the pivot man until the drum major gives the signal: **FORWARD, MARCH.** Guide then reverts to the center file.

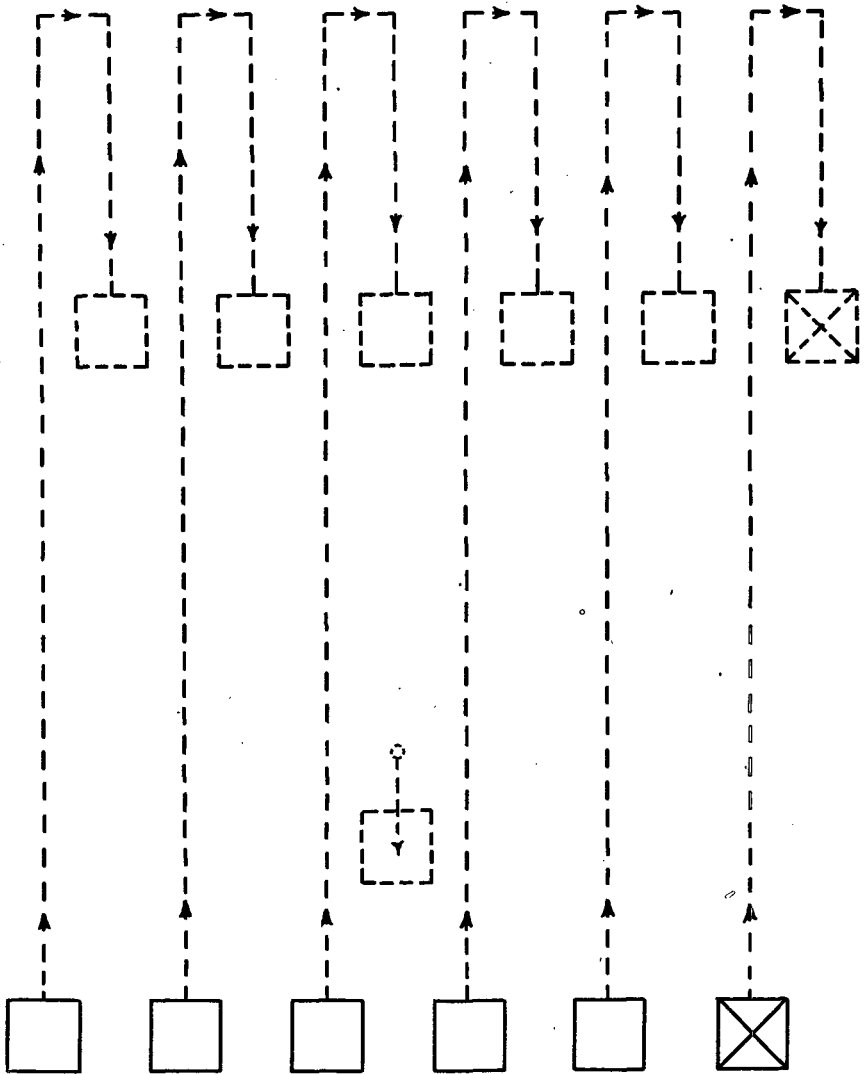


FIGURE 8. COUNTERMARCH.

**68. EXECUTION OF COUNTERMARCH.** To countermarch when the band is in playing formation, the command is: 1. COUNTERMARCH. 2. MARCH. 3. FORWARD. 4. MARCH. At the second command the entire band takes up the half step and the front rank executes two successive movements by the right flank. The movement is executed by each rank successively on the same ground and in the same manner. When the entire band has changed direction the drum major gives the command: 3. FORWARD. 4. MARCH, and the band resumes the march at full step. (See fig. 8.)

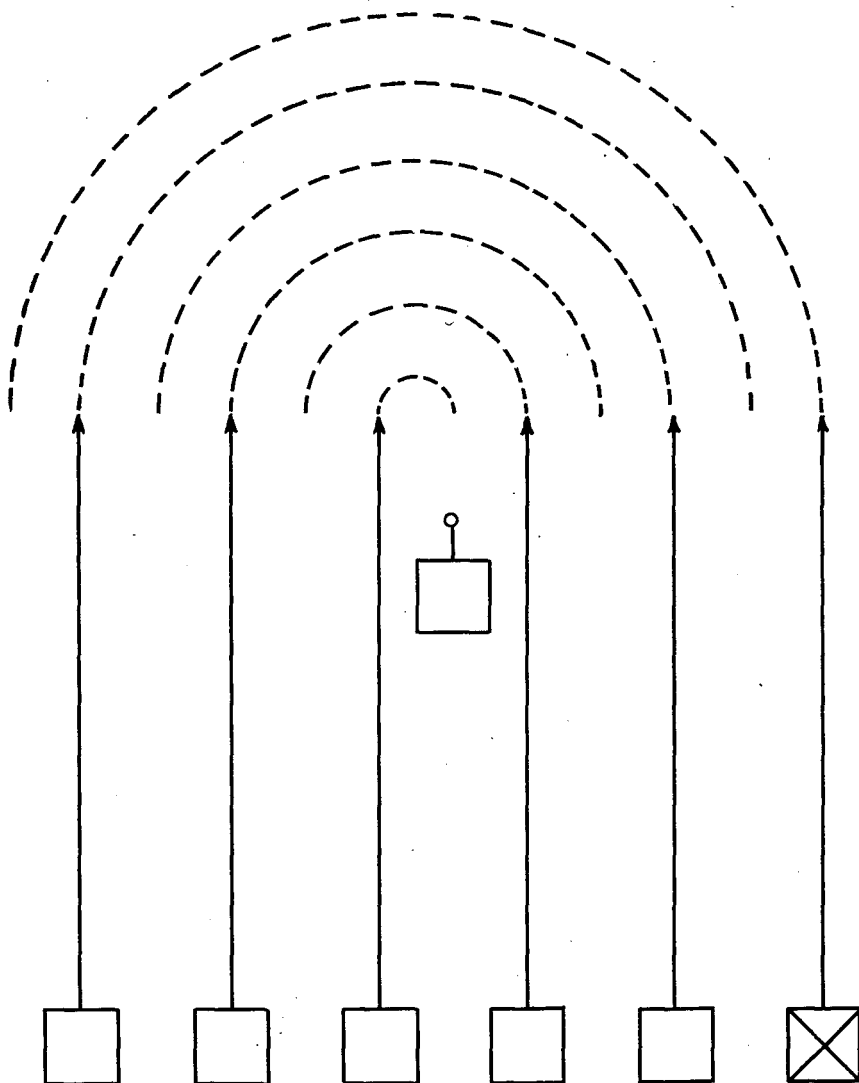
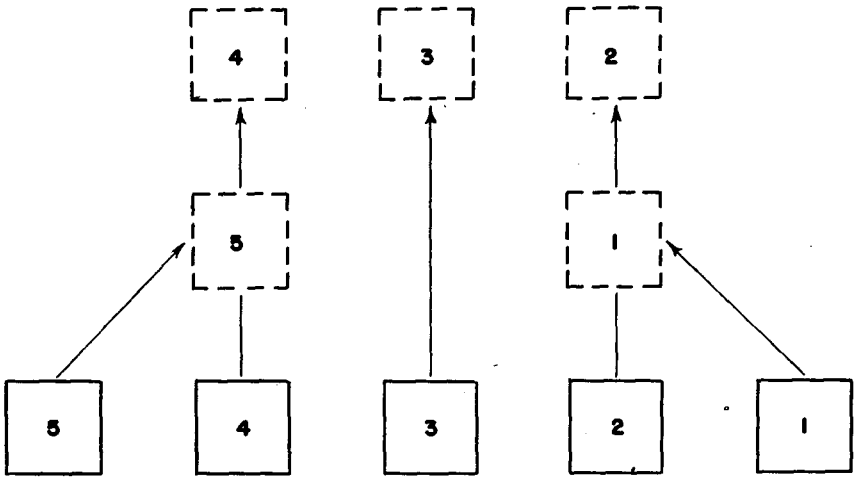


FIGURE 9. COUNTERMARCH, NONREVERSIBLE.

69. COUNTERMARCH, NONREVERSIBLE (OPTIONAL). The nonreversible countermarch (fig. 9) permits the band to march in the same pattern at all times. The center file takes up the half step on the command of execution. Other files march at full step until abreast of the center file. They then take up the half step until the movement is completed and the signal: 3. FORWARD and 4. MARCH is given. (See fig. 9.)

**70. INCREASE AND DECREASE FRONT.** Increase and decrease front may be used while marching when narrow streets or crowded traffic conditions prohibit marching with the normal front.



**FIGURE 10. TO DECREASE FRONT.**

**71. DECREASE FRONT WHILE MARCHING.** On the command MARCH, file No. 1 in each rank obliquates to position in the rear of file No. 2. File No. 5 obliquates to a position in the rear of file No. 4. (See fig. 10.) The front rank remains at full step. Files Nos. 2, 3, and 4 maintain a full step as nearly as possible until the distance is adjusted for all ranks.

**72. INCREASE FRONT WHILE MARCHING.** On the command MARCH, files Nos. 2, 3, and 4 of the front rank take up the half step. Files Nos. 1 and 5 oblique into positions beside files Nos. 2 and 4 respectively and resume forward direction. When all ranks have adjusted to the 60-inch distance, the command: FORWARD, MARCH is given. (See fig. 11.)

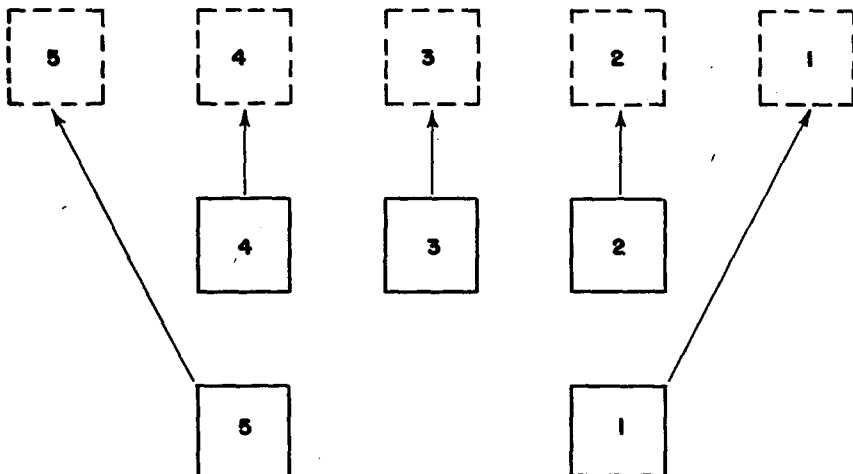


FIGURE 11. TO INCREASE FRONT.

**73. INCREASE FRONT AT THE HALT.** On the command: MARCH, files Nos. 2, 3, and 4 of the front rank stand fast. Files Nos. 1 and 5 of front rank move at the oblique to the proper position and face front. At the same time, remainder of files Nos. 1 and 5 oblique to proper positions. All ranks, beginning with the second, move forward to obtain proper distance of 60 inches. (See fig. 12.)

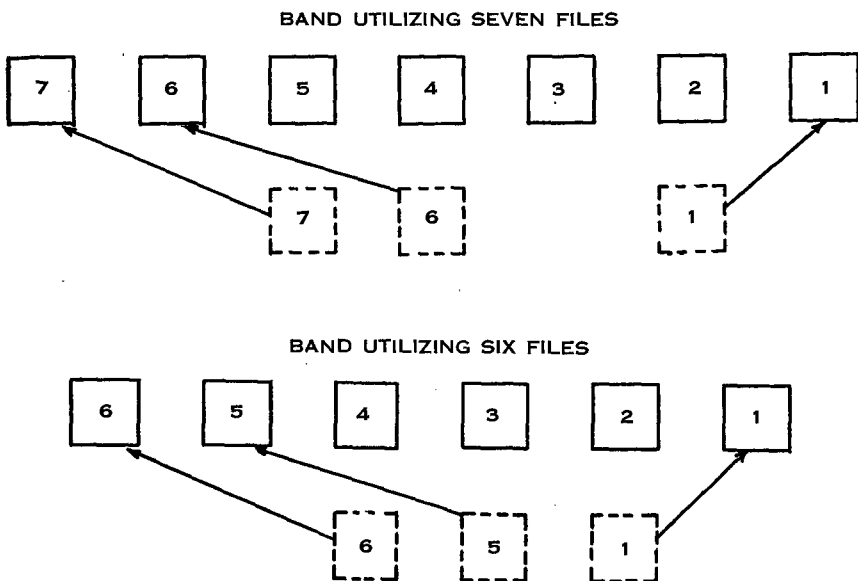


FIGURE 12. INCREASE OR DECREASE FRONT OF BANDS USING 6- AND 7-MAN FRONT.

**74. FLANK MOVEMENTS.** Flank movements are executed in the manner prescribed in FM 22-5.

#### Section IV. POSITIONS OF INSTRUMENTS

**75. POSITION OF "CARRY."** The CARRY position is that position which is most comfortable for the player, places the least strain on the instrument as regards serviceability, and guards against unnecessary accidents, and yet conforms to the necessary uniformity required of all marching soldiers.

**76. POSITION AT "ATTENTION."** The ATTENTION position, except for basses, bass drum, bell lyra and baritone saxophone (mentioned in later paragraphs), is the same as the position of CARRY. For the excepted instruments, they may be rested on the ground in the manner explained for each instrument by the respective men until such time as the band leader commands: READY.

**77. POSITION OF "PREPARE TO PLAY."** The instruments are brought up to playing position in two movements as explained in the following paragraphs. These movements, when properly executed by every man, will add uniformity of movement and will give a smart appearance and military snap that is well worth the time spent in perfecting them.

**78. POSITION OF "INSPECTION."** The inspection movements should be such as to bring the instruments into the best possible manner for the inspector to secure and inspect if he so desires. With the exception of the piccolo, these movements are executed in two counts. (See par. 79c.) Music is placed in pouches, but lyres remain attached to the instruments.

**79. FLUTE AND PICCOLO.** a. **Carry.** Grasp the keyed end of the instrument with the fingers of the right hand with the main body resting between thumb and index finger and held in a vertical position with the keys to the front. (See fig. 13 ①.)

b. **Prepare to play.** (1) Place rack under the left arm with the left hand and hold lyre until second movement. Right hand remains at carry. (See fig. 13 ②.)

(2) Bring instrument to playing position with the right hand, meanwhile placing the left hand to proper key position. (See fig. 13 ③.)

c. **Inspection.** (1) Raise instrument to a position diagonally across the chest with right arm semiextended and fingers of the left hand supporting the head. (See fig. 13 ④.)



FIGURE 13 (1)  
FLUTE AND PICCOLO



FIGURE 13 (2)

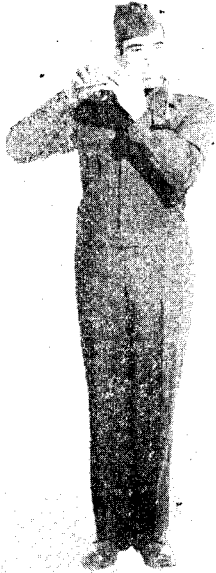


FIGURE 13 (3)



FIGURE 13 (4)



(2) After the instrument has been inspected return to first position. (See fig. 13 ①.)

**80. OBOE, E<sub>b</sub> AND B<sub>b</sub> CLARINET.** **a. Carry.** Grasp the bell of the instrument, placing the fingers of the right hand in the bell and hold it in a vertical position against the body. (See fig. 14 ①.)

**b. Prepare to play** (caps removed). (1) Extend the left arm across the body with fingers and thumb approximately covering the proper keys. (See fig. 14 ②.)

(2) Raise the instrument to the playing position with the right hand moving to the proper keys in one motion. (See fig. 14 ③.)

**c. Inspection.** (1) Extend the left arm across the body with the fingers and thumb grasping the barrel of the instrument. (See fig. 14 ④.)

(2) Raise instrument to a diagonal position across the chest. (See fig. 14 ⑤.)

(3) After the instrument has been inspected return to first position. (See fig. 14 ④.)

(4) To position of attention. (See fig. 14 ①.)

**81. ALTO SAXOPHONE AND ALTO CLARINET.** **a. Carry.** Grasp the middle section of the instrument with the right hand and hold it in a horizontal position. (See fig. 15 ①.)

**b. Prepare to play** (strap fastened, cap removed). (1) Extend the left arm across the body with the fingers approximately covering the proper keys. (See fig. 15 ②.)

(2) Bring the instrument to the playing position with the right hand moving to the proper keys in one movement. (See fig. 15 ③.)

**c. Inspection** (strap unfastened). (1) Extend the left arm across the body and grasp the instrument with the thumb and two fingers just above the keys. (See fig. 15 ④.)

(2) Raise the instrument to a diagonal position across the chest with right hand sliding downward supporting the lower end of the instrument. (See fig. 15 ⑤.)

(3) After the instrument has been inspected, return it to the first position. (See fig. 15 ④.)

(4) To position of attention. (See fig. 15 ①.) (Men playing instruments with straps should unfasten the strap prior to inspection.)



FIGURE 14 (1)  
OBOE, Eb AND  
Bb CLARINET

FIGURE 14 (2)



FIGURE 14 (3)

FIGURE 14 (5)



FIGURE 14 (4)



FIGURE 15 (1)  
ALTO SAXOPHONE  
AND ALTO CLARINET



FIGURE 15 (2)



FIGURE 15 (3)



FIGURE 15 (4)

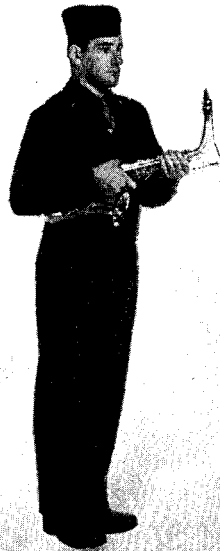


FIGURE 15 (5)

**82. TENOR SAXOPHONE AND BASS CLARINET.** a. **Carry.** Grasp the bell of the instrument with the right hand, and hold it in a vertical position with the neck of instrument extending over the right shoulder. (See fig. 16 ①.)

b. **Prepare to play** (strap fastened, cap removed). (1) Extend the left arm across the body with the fingers approximately covering the proper keys. (See fig. 16 ②.)

(2) Bring the instrument to a playing position with the right hand moving to the proper keys in one movement. (See fig. 16 ③.)

c. **Inspection** (strap unfastened). (1) Extend the left arm across the body, and grasp the instrument just above the keys. (See fig. 16 ④.)

(2) Bring the instrument to a diagonal position across the chest, with the right hand sliding downward supporting the lower end of the instrument. (See fig. 16 ⑤.)

(3) After the instrument has been inspected, return to the first position. (See fig. 16 ④.)

(4) To position of attention. (See fig. 16 ①.)



FIGURE 16 (1)  
TENOR SAXOPHONE  
AND BASS CLARINET



FIGURE 16 (2)



FIGURE 16 (3)



FIGURE 16 (5)



FIGURE 16 (4)

**83. BARITONE SAXOPHONE.** a. **Carry.** Grasp the bell of the instrument with the right hand and hold it in a vertical position with the neck of the instrument extending over the right shoulder. (See fig. 17 ①.)

b. **Prepare to play** (strap fastened). (1) Extend the left arm across the body with the fingers approximately covering the proper keys. (See fig. 17 ②.)

(2) Bring the instrument to the playing position with the right hand moving to proper keys in one movement. (See fig. 17 ③.)

c. **Inspection** (strap unfastened). (1) Extend the left arm across the body and grasp the front section of the neck pipe with the left hand. (See fig. 17 ④.)

(2) Raise the instrument to a diagonal position across the chest with the right hand sliding downward supporting the lower end of the instrument. (See fig. 17 ⑤.)

(3) After the instrument has been inspected, return it to the first position. (See fig. 17 ④.)

(4) To position of attention. (See fig. 17 ①.)



FIGURE 17 (1)  
BARITONE  
SAXOPHONE



FIGURE 17 (2)

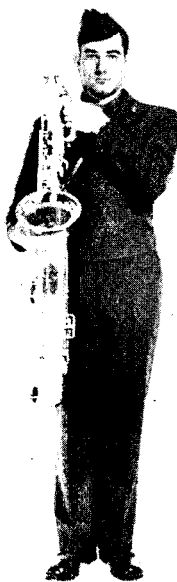


FIGURE 17 (4)



FIGURE 17 (3)



FIGURE 17 (5)

**84. BASSOON.** a. **Carry (strap fastened).** Grasp the center of the instrument with the right hand, close to the body and with the elbow and forearm supporting it. The instrument should be at an angle of approximately 40°. (See fig. 18 ①.)

b. **Prepare to play (strap fastened).** (1) Extend the left arm across the body with the fingers approximately covering the proper keys. (See fig. 18 ②.)

(2) Raise the instrument to the playing position with the right hand moving to the proper keys in one movement. (See fig. 18 ③.)

c. **Inspection (strap unfastened).** (1) Extend the left arm across the chest and grasp both sections of the instrument just below the neckpiece with the left hand. (See fig. 18 ④.)

(2) Raise the instrument to a diagonal position across the chest with the right hand supporting the lower section. (See fig. 18 ⑤.)

(3) After the instrument has been inspected, return it to the first position. (See fig. 18 ④.)

(4) To position of attention. (See fig. 18 ①.)





FIGURE 18 (1)  
BASSOON



FIGURE 18 (2)



FIGURE 18 (3)



FIGURE 18 (4)



FIGURE 18 (5)

**85. CORNET AND TRUMPET. a. Carry.** Grasp the valve casing with the left hand and hold the instrument in a diagonal position across and against the chest. (See fig. 19 ①.) (For long marches the instrument may be carried against the left side of the body prior to reaching the place of formation.)

**b. Prepare to play.** (1) Extend the left arm partly and hold the instrument in a vertical position with the right hand grasping the instrument as in the playing position. (See fig. 19 ②.)

(2) Raise the instrument to the playing position. (See fig. 19 ③.)

**c. Inspection.** From PREPARE FOR INSPECTION position (fig. 19 ④):

(1) Extend the left arm across the body and grasp the upper tubing of the instrument. (See fig. 19 ⑤.)

(2) With the left hand, bring the instrument to a diagonal position in front of the chest, and with the right hand grasp the instrument with fingers inside the bell and thumb on the rim in one movement. (See fig. 19 ⑥.)

(3) After the instrument has been inspected return it to the first position. (See fig. 19 ⑤.)

(4) To original position. (See fig. 19 ④.)



FIGURE 19 (1)  
CORNET AND TRUMPET



FIGURE 19 (2)

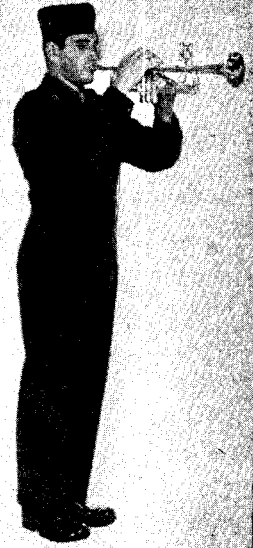


FIGURE 19 (3)



FIGURE 19 (4)



FIGURE 19 (5)



FIGURE 19 (6)

**86. FRENCH HORN AND MELOPHONE.** a. **Carry.** Hold the instrument against the right side of the body, mouthpiece up, and grasp the tubing at the lower part of the instrument directly below the valves with the right hand and brace the instrument against the body with the elbow and forearm. (See fig. 20 ①.)

b. **Prepare to play.** (1) Extend the left arm across the body and grasp instrument with the left hand with fingers in playing position. (See fig. 20 ②.)

(2) Raise the instrument to playing position with the right hand moving to the inside of the bell in one movement. (See fig. 20 ③.)

c. **Inspection.** (1) Grasp the instrument with the left hand as in PREPARE TO PLAY. (See fig. 20 ②.)

(2) With the left hand bring the instrument in front of the body with the right hand moving under the edge of the bell. (See fig. 20 ④.)

(3) After the instrument has been inspected, return it to first position. (See fig. 20 ②.)

(4) To position of attention. (See fig. 20 ①.)

d. **Melophone.** For Melophone, substitute right for left, and left for right wherever it appears in the above explanation. Place the left hand under the edge of the bell.



FIGURE 20 (1)  
FRENCH HORN  
AND MELLOPHONE

FIGURE 20 (4)

FIGURE 20 (2).

FIGURE 20 (3)

**87. BARITONE, EUPHONIUM. a. Carry.** (1) For American model with side or front action valves, hold the instrument against the right side of the body, bell forward. (See fig. 21 ①.)

(2) For European model (upright action) instruments are held and all movements executed in a similar manner but in reverse position.

**b. Prepare to play.** (1) Extend the left arm across the body and grasp instrument at the portion of tubing as for playing position.

(See fig. 21 ②.)

(2) Raise the instrument to playing position with the right hand moving to the valves in one movement. (See fig. 21 ③.)

**c. Inspection.** (1) Grasp turn in main tubing with the left hand. (See fig. 21 ④.)

(2) Raise instrument to a diagonal position in front of the body with the right hand sliding downward to support lower end of instrument. (See fig. 21 ⑤.)

(3) After the instrument has been inspected, return to first position. (See fig. 21 ④.)

(4) To position of attention. (See fig. 21 ①.)



FIGURE 21 (1)  
BARITONE EUPHONIUM



FIGURE 21 (2)



FIGURE 21 (3)



FIGURE 21 (4)



FIGURE 21 (5)

**88. TROMBONE. a. Carry.** Grasp instrument in the left hand, little finger under the slide brace, index, third, and fourth fingers between the slide brace and the mouthpiece brace, and hold diagonally in front of the body, bell down. (See fig. 22 ①.)

**b. Prepare to play** (slide unlocked). (1) Partly extend the left arm and hold instrument in a vertical position. Meanwhile grasp the slide brace with the right hand and remove the little finger of the left hand from slide brace. (See fig. 22 ②.)

(2) Bring instrument to playing position. (See fig. 22 ③.)

**c. Inspection** (slide locked). (1) Extend the left arm and hold the instrument in a diagonal position. (See fig. 22 ④.)

(2) Grasp slide tubing with the right hand. (See fig. 22 ⑤.)

(3) After instrument has been inspected, return it to first position. (See fig. 22 ④.)

(4) To position of attention. (See fig. 22 ①.)





FIGURE 22 (1)  
TROMBONE

FIGURE 22 (2)

FIGURE 22 (4)

FIGURE 22 (3)

FIGURE 22 (5)

**89. E<sub>b</sub> AND BB<sub>b</sub> BASSES.** a. **Carry.** (1) To prevent the man from becoming fatigued, for long marches and prior to reaching the place of formation, the instrument may be carried either on the left or right shoulder. (See fig. 23 ①—left, fig. 23 ②—right.)

(2) So that the instrument may not interfere with the proper alignment of the band, as the band leader dresses the band, the instrument is placed on the ground as shown in figure 23 ③. This same position may also be used during the Manual of Arms at parade, and during such other long periods when the band does not play. In order to maintain uniformity, care must be taken to raise all bases simultaneously, just before playing the next number. This can be done through a previously arranged signal or command.

b. **Prepare to play.** (1) For this movement the man remains in position of attention. (See fig. 23 ④.)

(2) Place the hands in position for playing. (See fig. 23 ⑤.)

c. **Inspection.** Same position as carry. (See fig. 23 ④.)



FIGURE 23 (1)  
E $\flat$  AND B $\flat\flat$  BASSES



FIGURE 23 (2)



FIGURE 23 (4)

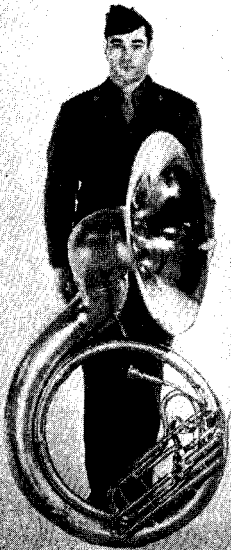


FIGURE 23 (3)



FIGURE 23 (5)

**90. DRUM, SNARE, FIELD.** a. **Carry.** Carry at the left side of the body supported by sling over the right shoulder with left hand resting on rim and the right hand holding drum sticks. (See fig. 24 ①.)

b. **Prepare to play.** (1) By a firm grip on rim with the left hand, pull drum slightly away from the body, rotate drum slightly to the left so that the hand is in rear, and push instrument forward diagonally so that the drum is brought to playing position. (See fig. 24 ②.)

(2) Move both hands toward each other in front of the body, and with the left hand secure proper stick, and resume position for playing. (See fig. 24 ③.)

c. **Inspection** (sling unfastened). Being at position of carry:

(1) Extend the right arm across the body (sticks in hand) and grasp opposite rim of drum, thumb on top of rim. (See fig. 24 ④.)

(2) Bring instrument forward and up in front of the center of the waist. (See fig. 24 ⑤.)

(3) After the instrument has been inspected return to first position. (See fig. 24 ④.)

(4) Fasten sling and assume position of attention. (See fig. 24 ①.)

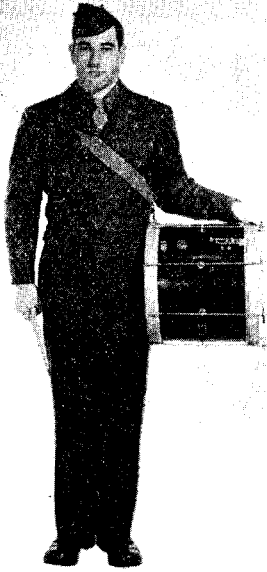


FIGURE 24 (1)  
DRUM, SNARE, FIELD



FIGURE 24 (2)



FIGURE 24 (3)

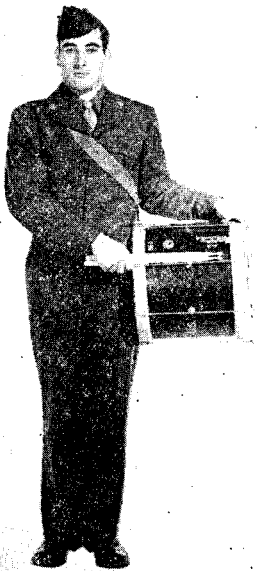


FIGURE 24 (4)



FIGURE 24 (5)

**91. DRUM, BASS.** **a. Carry.** For long marches an extra sling (in lieu of an extra sling, a braided rope may be fastened to the drum and used for that purpose), is carried and slung over left shoulder supporting the drum on the left side of the body, with the left arm steadying the instrument by holding the rim farthest from body. (See fig. 25 ①.) To prevent fatigue, the sling may be allowed to slide down on to the elbow as an alternate position. (See fig. 25 ②.) For dressing and aligning the band, the Manual of Arms at parades, and for such other periods when the band does not play, the drum should rest on the ground and in front of the man. (See fig. 25 ③.)

**b. Prepare to Play.** (1) With the right hand grasp the drum by the ropes or rod as the case may be and raise it approximately one foot off the ground with the left hand on the rim. (See fig. 25 ④.)

(2) With the right hand raise drum to the hood of the sling, and move left hand simultaneously to place the hook into the ring on the drum for that purpose. (See fig. 25 ⑤.)

**c. Inspection.** Instrument is placed on the ground at the left side of the man with drum stick in the right hand. (See fig. 25 ⑥.)

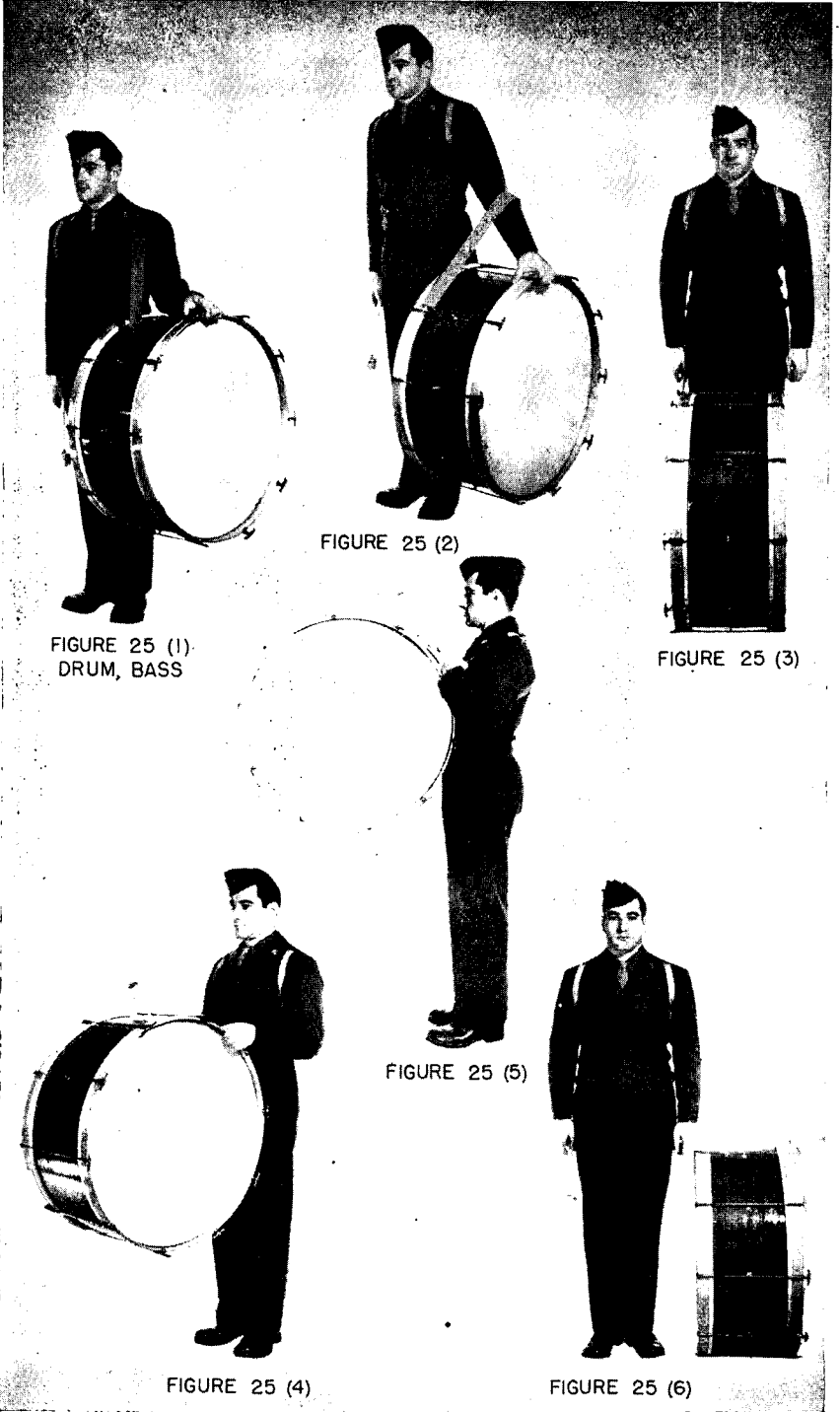


FIGURE 25 (1)  
DRUM, BASS

FIGURE 25 (2)

FIGURE 25 (3)

FIGURE 25 (5)

FIGURE 25 (4)

FIGURE 25 (6)

**92. CYMBALS.** a. **Carry.** Except for long marches when both cymbals are carried by the left (or right) hand against the body and supported by the elbow and forearm (fig. 26 ①), they are carried one in each hand with the arms hanging naturally at sides and the concave sides of cymbals toward each other. (See fig. 26 ②.)

b. **Prepare to play.** (1) Raise both cymbals chest high. (See fig. 26 ③.)

(2) Raise right-hand cymbal several inches or at the desired height preparatory to playing. (See fig. 26 ④.)

c. **Inspection** (from position of carry). (1) Raise cymbals chest high facing each other and in front of shoulders. (See fig. 26 ⑤.)

(2) Turn cymbals with wrist motion so that concave sides are exposed. (See fig. 26 ⑥.)

(3) After cymbals have been inspected return to first position. (See fig. 26 ⑤.)

(4) To position of attention. (See fig. 26 ②.)





FIGURE 26 (1)  
CYMBALS



FIGURE 26 (2)



FIGURE 26 (3)

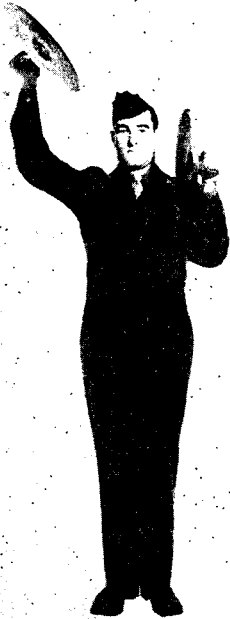


FIGURE 26 (4)

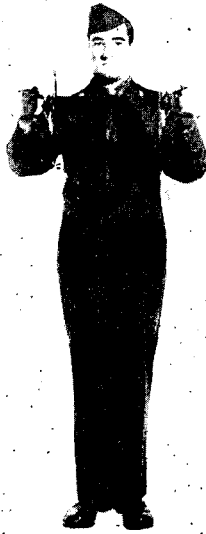


FIGURE 26 (5)



FIGURE 26 (6)

**93. BELL LYRA.** *a. Carry.* For long marches the instrument may be carried by either hand hanging naturally at the sides. (See fig. 27 ①.) As the band approaches the place of the actual formation or function, the lyra is carried under the right arm against the body with the right hand holding the left side of the frame and the bars away from the body. (See fig. 27 ②.) When standing at attention for long periods and not playing, the instrument is placed on the ground directly in front of the man and steadied from the upper curves of the frame with both hands and the bars toward the man. (See fig. 27 ③.)

*b. Prepare to play.* (1) Lift instrument with right hand, and with the left hand grasp extension shaft at base of frame. (See fig. 27 ④.) Guide shaft into harness pouch with the right hand. (See fig. 27 ⑤.)

(2) Right hand draws mallet from coat or belt where it is carried when not playing and assumes playing position. (See fig. 27 ⑥.) To release the weight of the instrument on the left arm while at playing position but not playing, the instrument may be brought closer to the body with the right side of the frame resting against the left shoulder (fig. 27 ⑦), as this places most of the weight directly in the harness pouch. For longer periods still, the instrument may be reversed and carried by the right hand. (See fig. 27 ⑧.) To place instrument on the ground from playing position—

(a) Grasp shaft at base of frame with right hand, and with the left hand grasp upper section of the right side of frame. (See fig. 27 ⑨.)

(b) Lift out of harness pouch letting left side of lyra drop down gently.

(c) With left hand still holding upper right side of frame, bring instrument under right arm, the right hand moving to lower frame. (See fig. 27 ⑩.)

(d) Let left hand drop naturally at side.

*c. Inspection.* As the inspector approaches—

(1) Lift instrument from ground position (figs. 27 ④ and 27 ⑤), as outlined in *b* above, leaving the mallet in the belt or coat.

(2) After the inspector has observed the back side of the instrument, with the right hand grasp right side of frame (fig. 27 ⑪) and let the instrument rotate by pulling the right side of the frame until the bars of the lyra are exposed to the inspector. (See fig. 27 ⑫.)

(3) After inspection, reverse the procedure. (See fig. 27 ⑬.)

(4) To ground position. (See fig. 27 ⑭.)

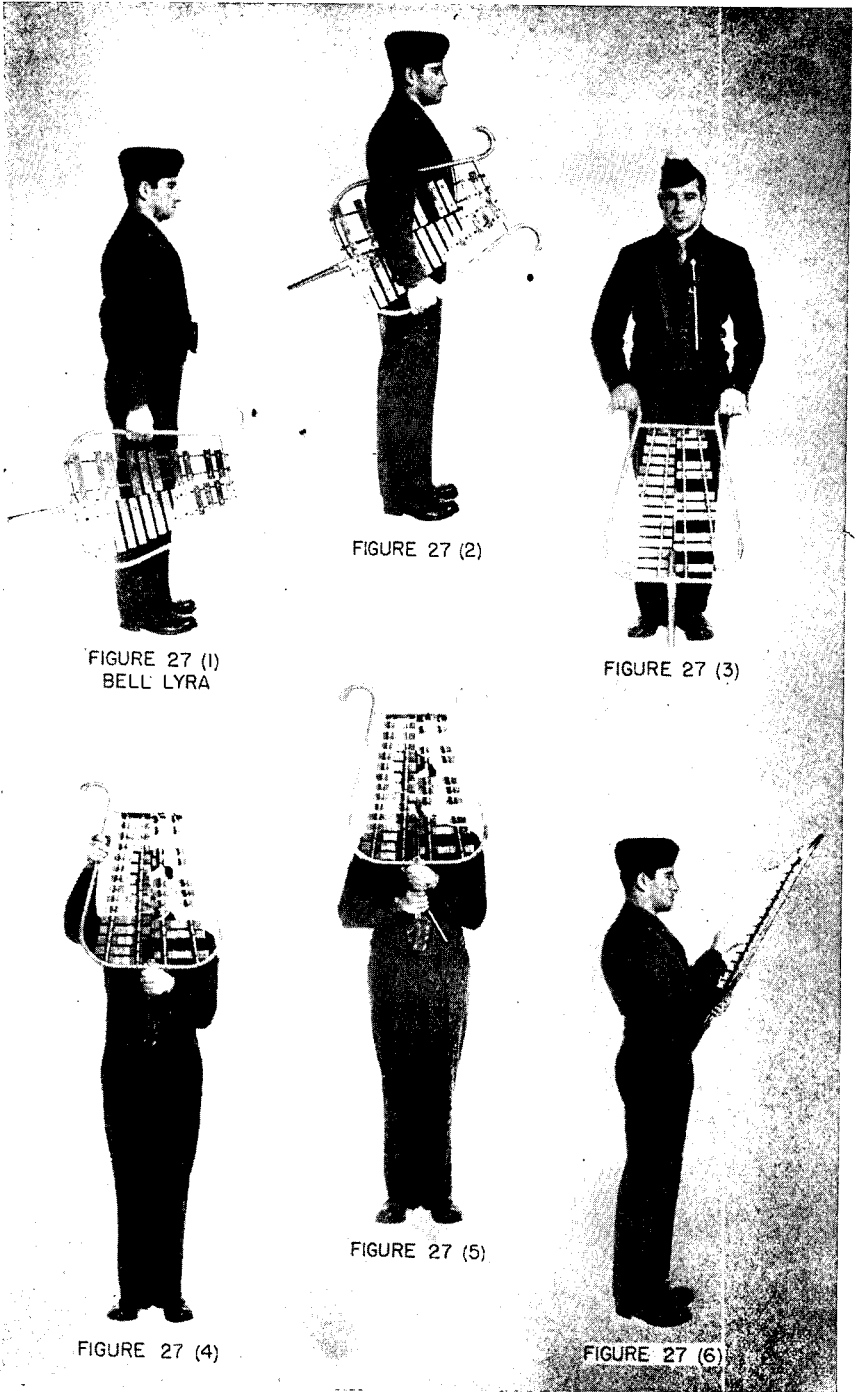


FIGURE 27 (1)  
BELL LYRA

FIGURE 27 (2)

FIGURE 27 (3)

FIGURE 27 (5)

FIGURE 27 (4)

FIGURE 27 (6)

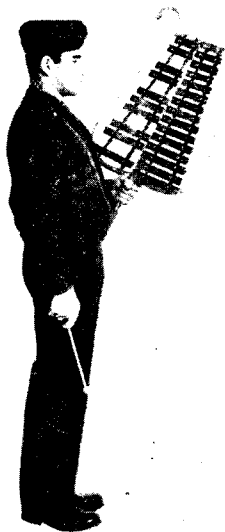


FIGURE 27 (7)  
BELL LYRA

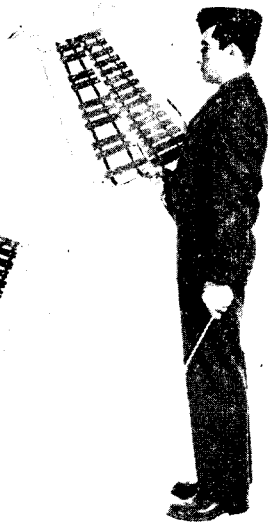


FIGURE 27 (8)



FIGURE 27 (9)

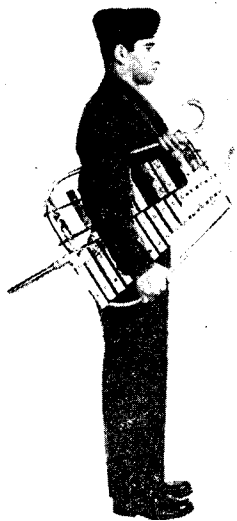


FIGURE 27 (10)



FIGURE 27 (11)



FIGURE 27 (12)

**94. BUGLE. a. Carry.** Habitually the bugle is carried under the left arm parallel to the ground and supported against the body by the elbow and forearm. (See fig. 28 ①.)

**b. Prepare to play.** Prior to a formation and change from carry, the chief bugler raises his right arm upwards and lowers it again in two counts. Then in cadence—

(1) All buglers bring instruments forward in front of body with the left hand, and with the right hand grasp the center of the instrument. (See fig. 28 ②.)

(2) Bring instrument to hip position (attention). (See fig. 28 ③.) Prior to playing (in cadence)—

(a) The chief bugler raises his bugle by extending his right arm fully upward. (See fig. 28 ④.)

(b) Returns bugle to original position. (See fig. 28 ③.)

(c) All buglers raise instruments upward to height of head (fig. 28 ⑤) and with wrist motion execute two forward twirls.

(d) Bring instrument to playing position (fig. 28 ⑥), remaining in that position for four beats or counts prior to the first beat of the march to be played. As these movements require 8 beats to complete them the field musicians execute them independently of the band proper.

(3) To change from playing to attention the chief bugler—

(a) Raises instrument fully upward as to prepare to play. (See fig. 28 ④.)

(b) Brings it back to playing position. (See fig. 28 ⑥.)

(c) All buglers extend the right arm fully to the right. (See fig. 28 ⑦.)

(d) Down to hip position. (See fig. 28 ③.)

**c. Inspection.** From position of attention (fig. 28 ③)—

(1) The instrument is brought in front of the chest with the left hand grasping upper curve of tubing. (See fig. 28 ⑧.)

(2) Right hand releases the grip on the instrument and grasps rim of bell nearest to him with fingers inside of bell. (See fig. 28 ⑨.)

(3) After the instrument has been inspected, return to first position. (See fig. 28 ⑧.)

(4) To position of attention. (See fig. 28 ③.)



FIGURE 28 (1)  
BUGLE



FIGURE 28 (2)

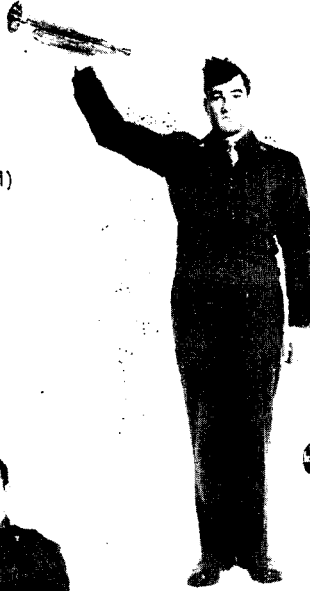


FIGURE 28 (4)

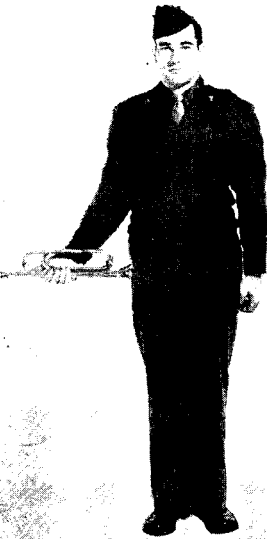


FIGURE 28 (3)

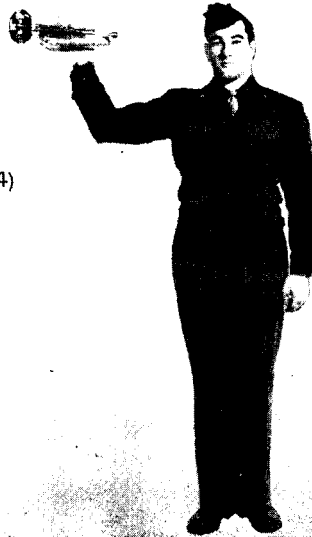


FIGURE 28 (5)



FIGURE 28 (6)  
BUGLE

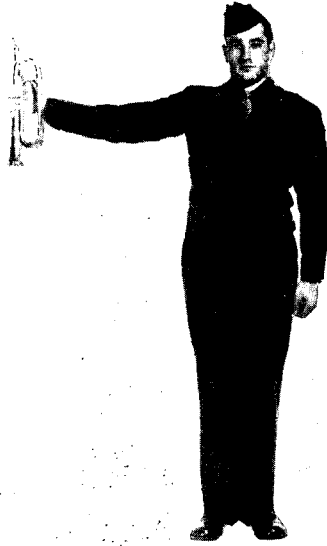


FIGURE 28 (7)



FIGURE 28 (8)



FIGURE 28 (9)

## Section V. MANUAL OF THE BATON

**95. THE BATON.** The baton (fig. 29) is carried by the drum major whenever instruments are carried by the band on the march.

**96. ORDER BATON.** The baton is held at an angle of 60° with the horizontal, ferrule on ground on a line with and touching the toe of the right shoe, ball up and to the right, right hand grasping staff near the ball, back of hand to front, left hand on hip, fingers in front and jointed, and thumb to the rear. (See fig. 30.) **ORDER BATON** is the habitual position of the baton when the band is at a halt in playing formation.

**97. CARRY BATON.** a. Raise the baton and carry staff to a position between right upper arm and side, ball up and slightly inclined to the front, right forearm nearly vertical; the staff grasped between the thumb and first two fingers, third and fourth fingers being closed against the palm of the hand and back of the hand to the right. At **CARRY BATON** in close formation, the left hand is at the side.

b. **CARRY BATON** is the habitual position of the baton when marching and the band is not playing, or when at a halt in close formation. (See figs. 31① and ②.)

c. In long marches when at attention, the drum major may carry baton under the left arm with the left hand grasping the staff instead of the right, as described above. This position is assumed in the most convenient manner.



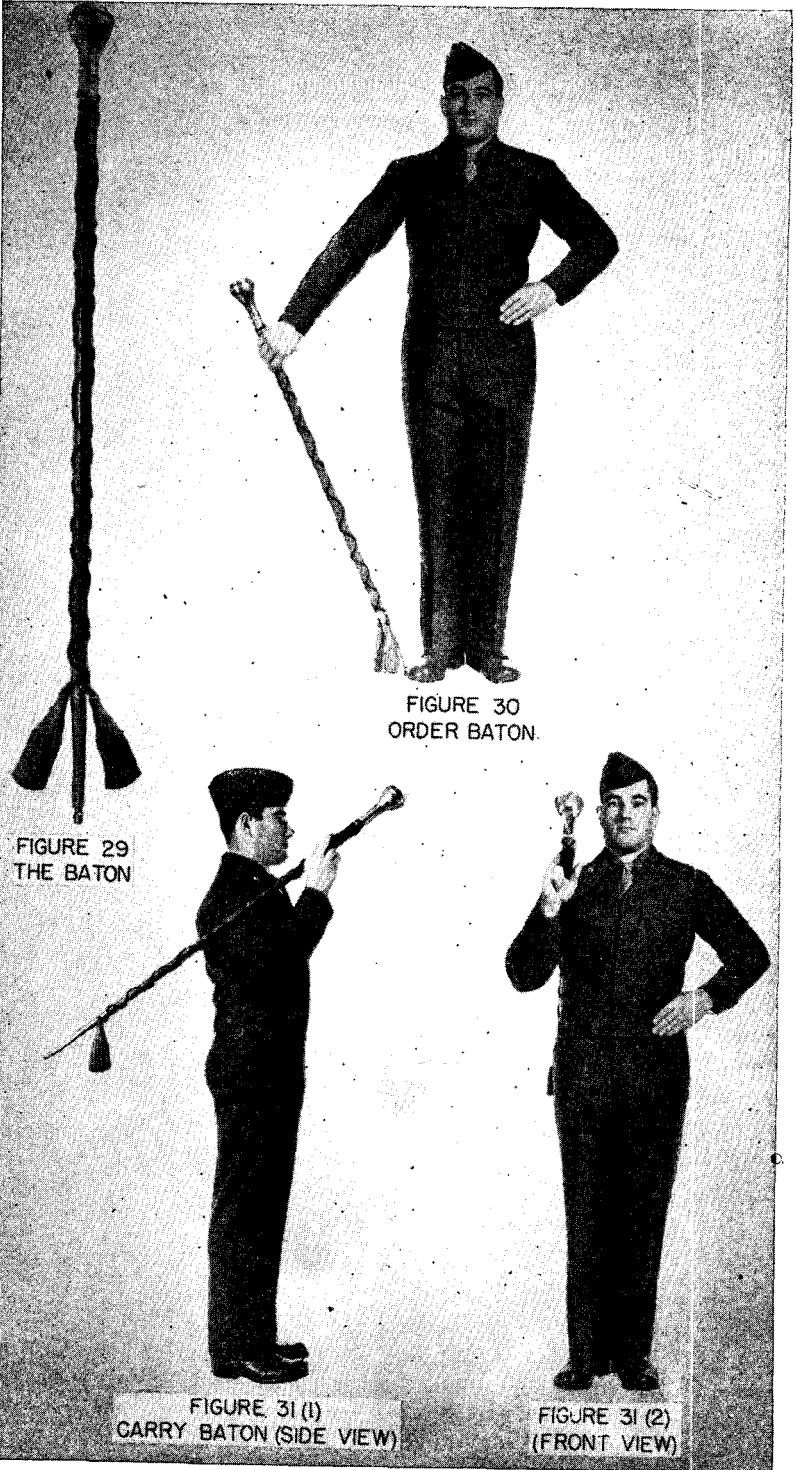


FIGURE 29  
THE BATON

FIGURE 30  
ORDER BATON.

FIGURE 31 (1)  
CARRY BATON (SIDE VIEW)

FIGURE 31 (2)  
(FRONT VIEW)



**98. PORT BATON.** Baton is diagonally across the body with the ball down and to the left (fig. 32 ①), the right hand close to and in front of the chest (fig. 32 ②), the back of hand to the front, and the left hand on hip.

**99. MARK CADENCE.** a. There are four distinct movements for every two measures of this function:

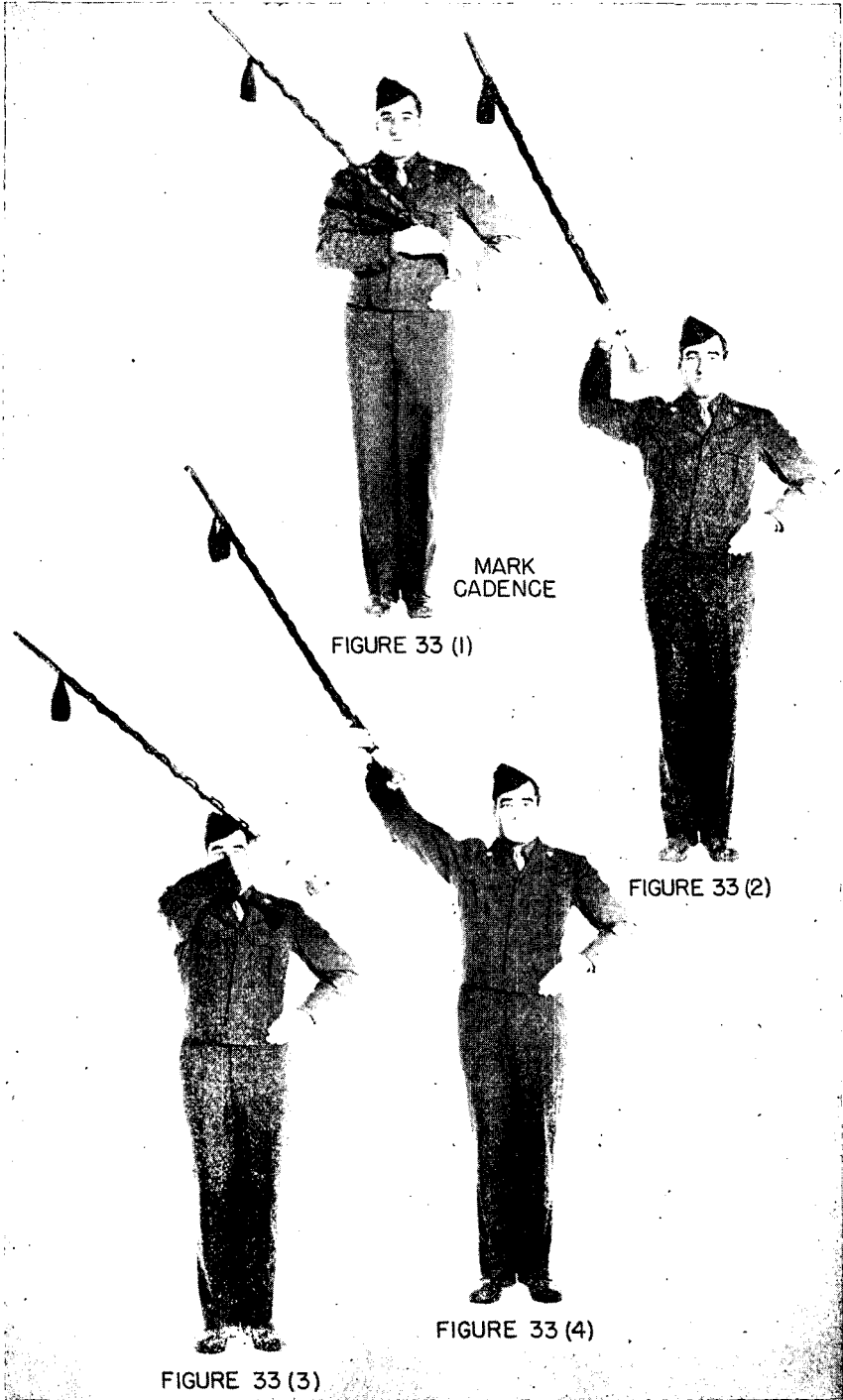
(1) Bring baton down full, extended as for play. (See fig. 33 ①.)

(2) Circle the baton up and to the right so that it stops beyond the right shoulder. (See fig. 33 ②.)

(3) Circle the baton slightly up and to the left so that ball of baton is above the left shoulder. (See fig. 33 ③.)

(4) Extend the right arm to its full length in the direction of the staff as for prepare to play. (See fig. 33 ④.)

b. **MARK CADENCE** is the habitual employment of the baton when the band is playing while marching.



MARK  
CADENCE

FIGURE 33 (1)

FIGURE 33 (2)

FIGURE 33 (4)

FIGURE 33 (3)

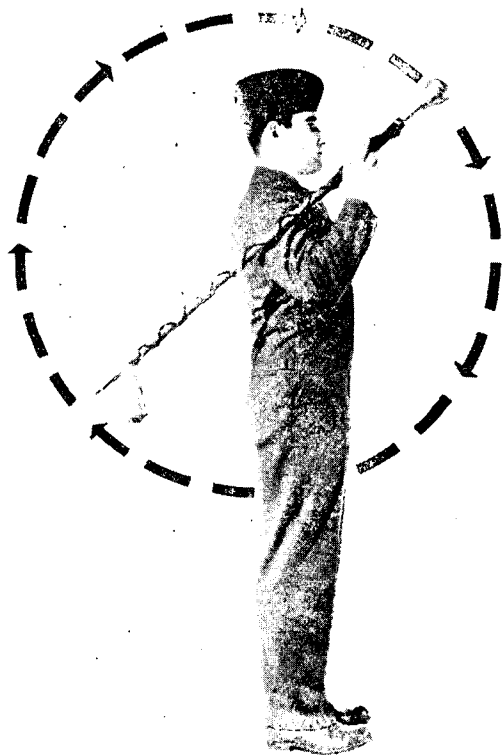


FIGURE 34  
THE TWIRL-- STARTING POSITION

**100. THE TWIRL.** The twirl is a forward circular motion of the baton, begun from the position pictured in figure 34. As the baton moves forward and downward the wrist is twisted outward: As the baton moves upward and over, the fingers are relaxed and opened to allow it to complete the circle.

**101. BATON SALUTE.** a. To execute the salute from ORDER BATON

(1) Raise the right arm to the front to a horizontal position fully extended which places the baton vertical, ball up. (See fig. 35 ①.)

(2) Move the right hand horizontally to the left with the baton remaining vertical until the right hand is against the left shoulder with the right forearm horizontal. (See fig. 35 ②.)

b. To execute BATON SALUTE from mark cadence, describe two twirls as shown in figure 34, execute CARRY BATON and thrust baton smartly forward in position of (1) above. (See fig. 35 ①.) Hold for one extra count, then bring the baton smartly to position in (2) above. (See fig. 35 ②.)

c. When the warrant officer band leader is armed with the saber, he executes PRESENT as the drum major executes ONE (fig. 35 ①), and SABER as drum major executes TWO. (See fig. 35 ②.) (See FM 22-5.)

**102. INSPECTION BATON.** From the order position swing the ferrule upward through front to horizontal, chest high. Grasp baton near the ferrule with the left hand, palm up. (See fig. 36.)

## Section VI. BATON SIGNALS

**103. PURPOSE.** All verbal commands are given by the band leader. The drum major acts as a guide, transmitting commands via the baton when the band is about to play or when verbal commands cannot be heard.

**104. CLASSES OF SIGNALS.** Baton signals are divided into two classes: preliminary and signal of execution. Unless otherwise prescribed, preliminary signals will be given from ORDER BATON.

**105. WHISTLE SIGNALS.** One long blast is customarily blown on the preliminary baton signal and one short blast accompanies the signal of execution. Whenever the proficiency of the organization permits, whistle signals should be eliminated.

**106. EXECUTION OF SIGNALS.** Positions and movements of the baton must be clear and precise at all times. Manual and signals of the baton must be vigorous and decisive. The band will respond in the same manner in which the commands are given.

**107. SECURE INSTRUMENTS.** As the drum major comes to PORT BATON bandsmen execute ONE of PREPARE TO PLAY as explained for



FIGURE 35 (1)  
BATON SALUTE



FIGURE 35 (2)



FIGURE 36  
INSPECTION BATON

all instruments in previous paragraphs. As the drum major raises baton (fig. 33 ④) bandmen execute TWO (playing position).

**108. PREPARE TO PLAY** a. When the band is to begin to play in place, the drum major brings baton to CARRY, faces about and:

(1) Executes PORT BATON. At this signal all bandmen execute ONE of PREPARE TO PLAY.

(2) Extends right arm to its full length in direction of baton. (See fig. 33 ④.) At this signal all bandmen execute TWO of PREPARE TO PLAY (playing position).

b. In cadence:

(1) Swing baton smartly to a point above and forward of the head. (See fig. 33 ③.)

(2) Return baton to extended position. (See fig. 33 ④.)

(3) Bring baton down extending arm toward left hip. (See fig. 33 ①.) Band plays.

(4) Bring baton to CARRY, face about and resume ORDER BATON.

**109. CEASE PLAYING.** The drum major faces the band and plans to stop the playing of the band on the first beat of the last measure of a period (double phrase) in seven counts as follows: For the first two measures (four beats) he twirls the baton backward, with the entire arm and as high as possible. This will give all players sufficient warning and attract every man's attention preparatory to CEASE PLAYING. On the first beat of the third measure he proceeds to give the same signals as for PREPARE TO PLAY, stopping on the down beat of the fourth measure. (See figs. 33 ①, ② and ③.) After the band has ceased playing, all men remain at playing position until the drum major brings baton to CARRY when all men, except those playing cornet (trumpet) and trombone, reverse the process of PREPARE TO PLAY by executing TWO, and two beats later when the drum major faces about, they execute ONE. Men playing cornet (trumpet) and trombone execute CARRY position but with the right hand fingers still on valves for the first movement, dropping the right hands to their sides on second movement.

**110. SOUND OFF.** a. First prepare the band to play as outlined in paragraph 108a. Then bring the baton smartly to PORT at which time the band begins to play the SOUND OFF chords. (See fig. 37.) Baton is raised on second beat of first measure. Lower and raise baton on first and second beat of second measure. Lower baton on first beat of third measure. Drum major then executes 1. ABOUT, 2. FACE on second beat of third measure



THE FIRST SOUND OFF IS IN THE KEY OF THE STRAIN OF THE MARCH WHICH FOLLOWS.

THE SECOND SOUND OFF IS IN THE KEY OF THE STRAIN BEING PLAYED AS THE MOVEMENT IS COMPLETED.

PERCUSSION

FL. & PIC.	8-7-8	2ND HORN	5-5-5	BAR SAX	1-5-1	. BARITONE	3-4-3
1ST CLAR.	8-7-8	3RD HORN	3-4-3	OBOE	8-7-8	1ST TRBN.	1-5-1
1ST CLAR.	5-5-5	4TH HORN	3-2-3	1ST CORNET	8-7-8	2ND TRBN	3-2-3
3RD CLAR.	3-2-3	ALTO SAX	5-4-5	2ND CORNET	5-5-5	3RD TRBN	8-7-8
1ST HORN	8-7-8 (3-4-3)	TENOR SAX.	3-4-3	3RD CORNET	3-2-3	BASSES	5-5-5
							1-5-1

FIGURE 37. SOUND OFF.

and first beat of fourth measure, respectively. Raise the baton, pointing straight ahead (fig. 38), on second beat of fourth measure. Band steps off playing on the next beat to TROOP THE LINE. After returning to original place, baton signals are given facing the band, first indicating CEASE PLAYING as outlined in paragraph 108b, and without breaking the cadence, repeat the same signals given for the first two measures of the SOUND OFF before TROOPING THE LINE and continuing with the movements outlined for CEASE PLAYING.

b. To SOUND OFF IN PLACE, the procedure is the same except that instead of TROOPING THE LINE, the band stands fast as it plays one strain of the march once through, and the drum major faces the band for the entire procedure.

**111. FORWARD MOVEMENT.** As the band leader gives the READY, drum major and bandsmen execute ONE of PREPARE TO PLAY. At the command FORWARD, drum major extends baton upward and forward (fig. 38) and bandsmen execute TWO of PREPARE TO PLAY. At the command MARCH, the band steps off playing.

**112. CEASE PLAYING WHILE MARCHING.** At the completion of the march or as the band leader may direct, the drum major will cause the band to cease playing and instruments returned as outlined in paragraph 109, after which the drummers will resume the street beat.

**113. ROLL OFF.** When the band is marching at attention with drum beats and the band leader desires that the band play, he will direct the drum major to signal the drummers to finish the street beat. From CARRY, the drum major will raise his baton—Ball Up—by—

a. Grasping baton with the left hand just below the right, and;

b. Pull it forward from under the right arm as the right hand releases grip, moves to regrab baton just above ferrule.

c. Right hand raises baton upward as left hand releases grip but remains in relative position so that procedure is reversed as soon as drum major is certain that all drummers have noticed the signal. As soon as the street beat pattern then in use is completed, the drummers will ROLL OFF. (See fig. 39.) On the first beat of the second and third measures of the ROLL OFF the drum major and bandsmen will execute ONE and TWO of PREPARE TO PLAY. They will remain in this position for the remainder of the ROLL OFF and start playing on the next down beat.



FIGURE 38  
FORWARD

FIGURE 39. ROLL OFF.

**114. PREPARE TO HALT.** a. Drum major faces the band. Lowers ferrule to left, allowing staff to fall into raised left hand at height of shoulder, thumb to front, and raises baton horizontally above head with both hands, arms fully extended. (See fig. 40.)

b. On the second beat prior to that on which HALT is to be executed, baton is lowered slightly, with wrist movement only. On next beat raise baton again as shown in figure 40.

c. HALT. Lower baton smartly to level of hips. (See fig. 41.) Two more counts complete the movement as prescribed in FM 22-5.

**115. COUNTER MARCH.** a. If the band is not playing, the band leader commands: 1. COUNTERMARCH, 2. MARCH. At the preliminary command, the drum major right steps one pace to the right and marks time. At the command of execution 2, given when the front rank has taken four paces beyond the drum major, the movement is executed as outlined in figure 8, with the drum major marching backward until he is clear of the last rank when he turns about and, with the band, marches at half step. When the entire band has completed the movement, the band leader commands: 1. FORWARD, 2. MARCH.

b. If the band is playing the drum major replaces commands with signals: 1. COUNTERMARCH (fig. 42 ①), 2. MARCH. (See fig. 42 ② or whistle signal.)

**116. RIGHT TURN.** a. Execute two forward twirls, terminating with right arm extending ball of baton fully to the left. (See fig. 43 ①.)

b. MARCH. A long jab to the right is made, extending the arm fully as the right foot strikes the ground. (See fig. 43 ②.)

**117. LEFT TURN.** a. Execute two forward twirls, terminating with the right arm extending ball of baton fully to the right. (See fig. 44 ①.)

b. MARCH. A long jab to the left is given, extending arm fully to the left as the left foot strikes the ground. (See fig. 44 ②.)

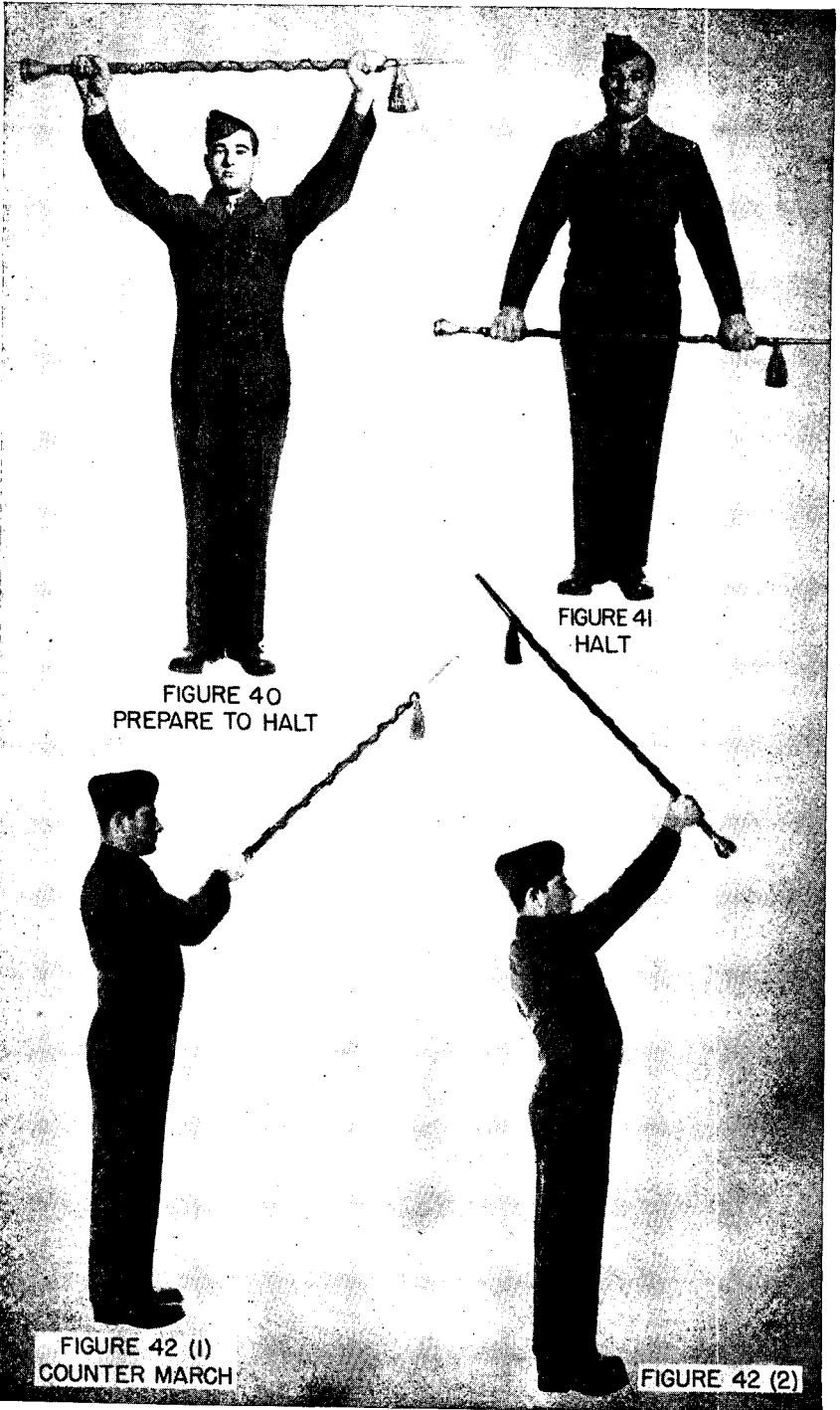


FIGURE 40  
PREPARE TO HALT

FIGURE 41  
HALT

FIGURE 42 (1)  
COUNTER MARCH

FIGURE 42 (2)

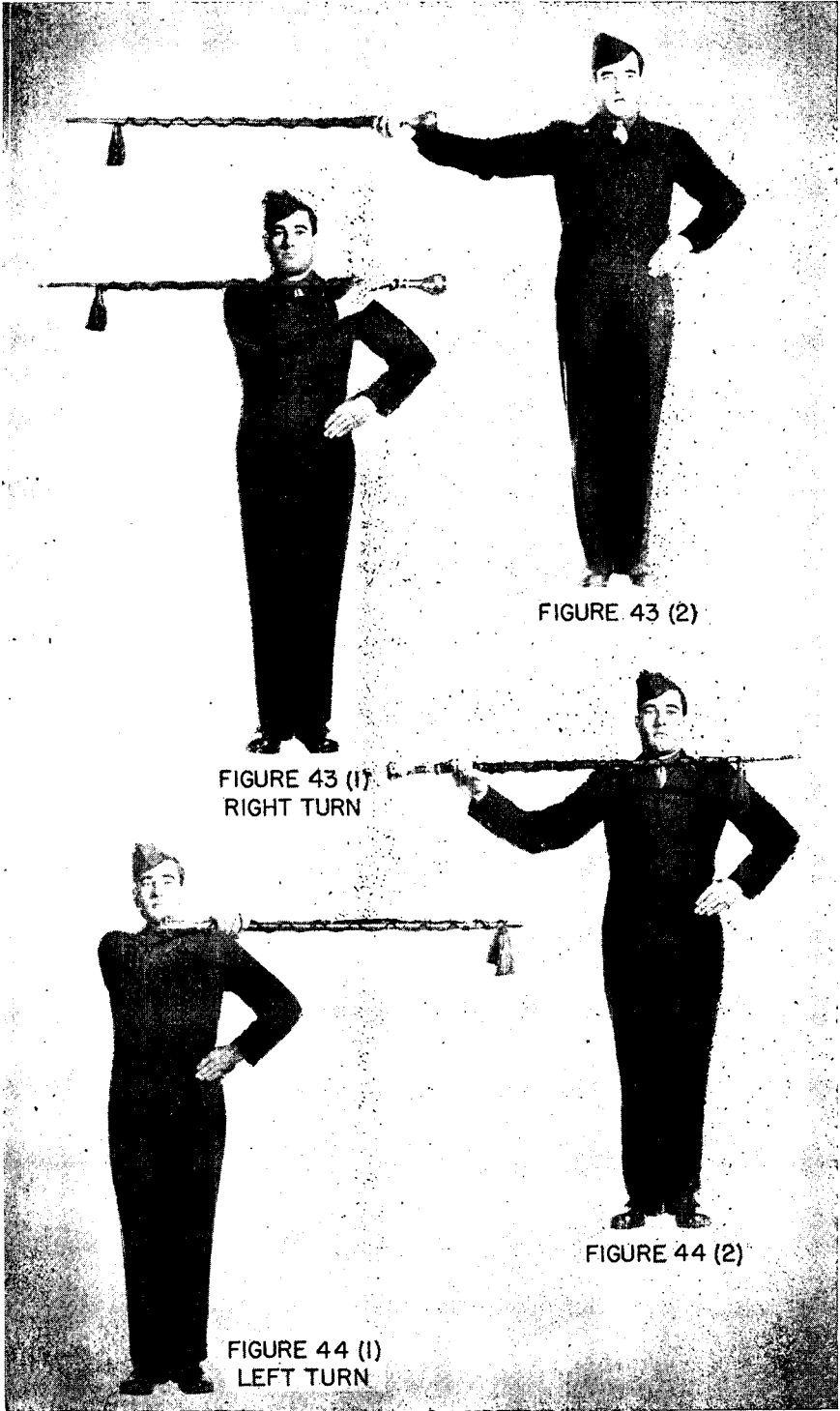


FIGURE 43 (1)  
RIGHT TURN

FIGURE 43 (2)

FIGURE 44 (1)  
LEFT TURN

FIGURE 44 (2)

**118. BY THE RIGHT FLANK.** a. Execute two forward twirls. Extend the right arm to its full height, baton horizontal to ground, ferrule pointing to the right. (See fig. 45 ①.)

b. MARCH. Extend baton smartly to the right as the right foot strikes ground. (See fig. 45 ②.)

**119. BY THE LEFT FLANK.** a. Execute two forward twirls. Extend the right arm to its full height, baton horizontal to ground, ferrule pointing to the left. (See fig. 46 ①.)

b. MARCH. Extend baton smartly to the left as the left foot strikes the ground. (See fig. 46 ②.)

**120. INCREASE (DECREASE) FRONT.** a. Baton being employed in MARK CADENCE, terminate movement as right arm is extended to right. Swing ferrule end of baton to the left grasping that end with left hand. Extend both arms to full height over head. (See fig. 40.)

b. Pull right hand down, baton forming an angle of  $450^\circ$  to the horizontal. (See fig. 47.)

c. The same baton signals are used both for increase or decrease front.

**121. TO CHANGE FORMATION WHILE PLAYING** (close to playing formation or vice versa). a. **Close formation.** (Playing formation.) Drum major, facing away from band, extends both arms out to the side to the horizontal position. The baton is vertical with the ferrule up, the palm of the left hand down. (See fig. 48 ①.)

b. MARCH. Both arms are brought straight upward through the side, the baton and right arm forming a vertical line, while the left arm is straight with the palm in. (See fig. 48 ②.)

**122. DRUMS TO PLAY ON RIM** (on head). a. **On rim** (head). Right arm is extended above the head with hand grasping staff just above ferrule. Baton vertical with ball up. Describe several circles in the air with ball end of baton. (See fig. 49.)

b. PLAY. Drop baton through hand to normal placement on staff.

c. The same signal is used for both ON RIM and ON HEAD. When drummers are playing ON RIM signal indicates ON HEAD and vice versa.



FIGURE 45 (1)  
BY THE RIGHT FLANK



FIGURE 45 (2)



FIGURE 46 (1)  
BY THE LEFT FLANK



FIGURE 46 (2)



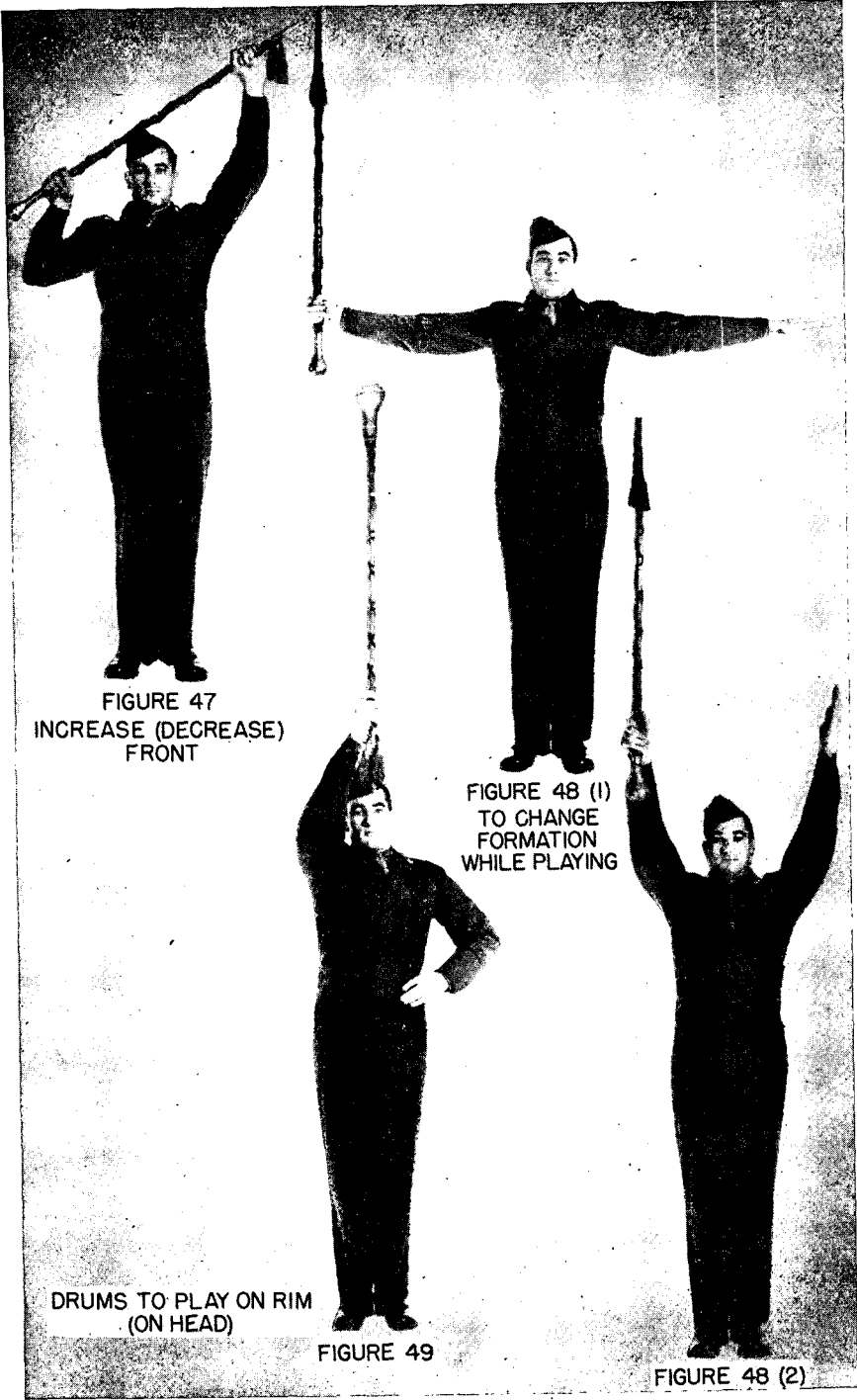


FIGURE 47  
INCREASE (DECREASE)  
FRONT

FIGURE 48 (1)  
TO CHANGE  
FORMATION  
WHILE PLAYING

DRUMS TO PLAY ON RIM  
(ON HEAD)

FIGURE 49

FIGURE 48 (2)

## CHAPTER 4

### CEREMONIES

---

#### Section I. PARADES

**123. SPECIAL CEREMONIAL PARADE.** a. **Battalion.** (1) The normal position of the band for this ceremony is 12 paces to the **right** and on line with the line of troops. The adjutant, from his post on the left flank of the band commands: **SOUND ADJUTANT'S CALL.**

(2) The band leader brings the band to attention and instructs the sergeant bugler to sound adjutant's call (if no field music the trumpet section of the band plays, in unison, all calls ordinarily played by the field music under the direction of the senior bandsman in the section.)

(3) The drum major, facing the band, will give the proper baton signals to start the band playing a march on the accented beat immediately following the completion of the adjutant's call. He will then turn about and face to the front. (The drum major will never mark cadence while the band is at a halt. Any discrepancy in tempo of music played will be adjusted by the band leader.)

(4) The band leader will ascertain when all troops have reached their positions on the line and will signal the drum major to give the baton signal to **CEASE PLAYING.** Drum major faces the band when giving this signal and will again face to the front when band has stopped playing.

(5) The adjutant, after posting the guides and having taken his post between the battalion commander and the center of the line of troops, gives the command: **1. PARADE, 2. REST.** After the troops have executed parade rest, the adjutant commands: **SOUND OFF** (or signals the band leader to that effect).

(6) The drum major, facing to the front, gives the baton signal to **SOUND OFF** (par. 110) and the band **IN PLACE**, plays three chords in the key of the march which is to follow. (See fig. 37.) On completion of the three chords the band steps off on the first beat of the measure immediately following the sound off.

(7) The band marches midway between the adjutant and the line of troops as shown in diagram in fig. 50. Band leader and

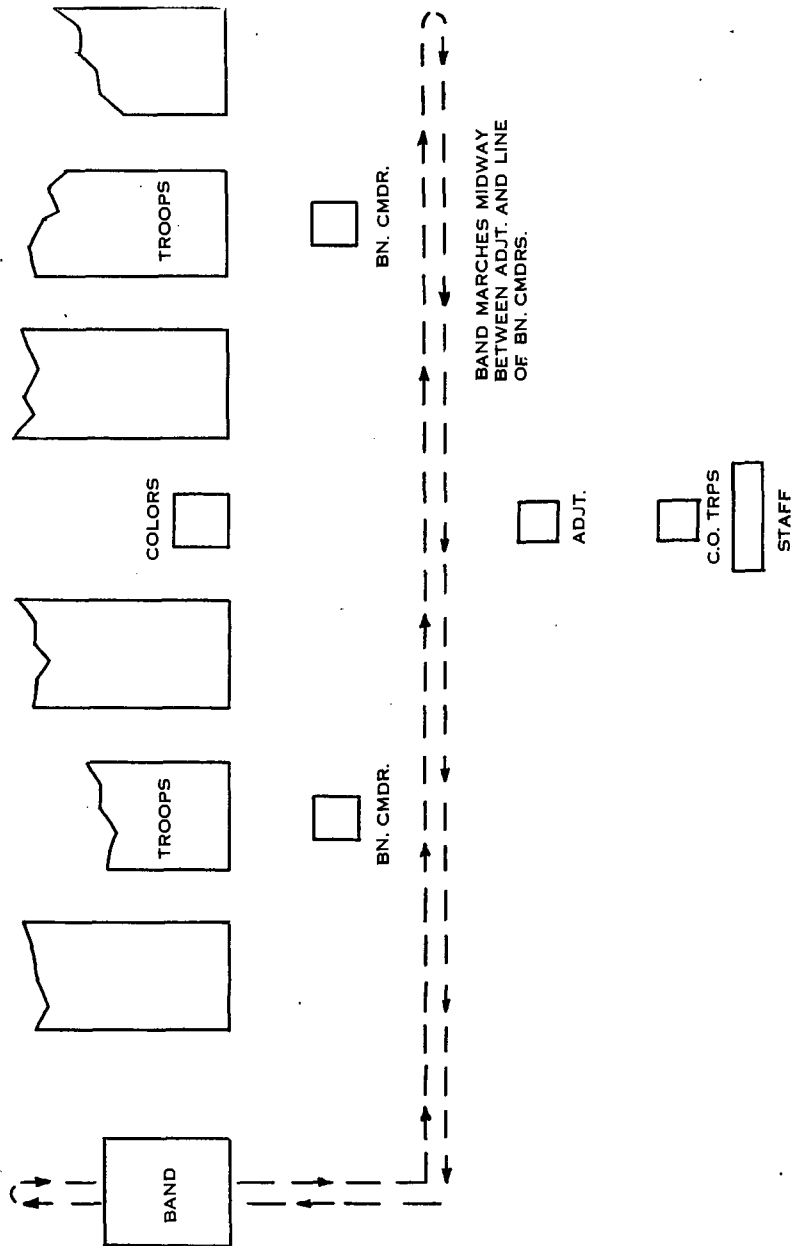


FIGURE 50. TROOPING THE LINE DURING SOUND OFF.

drum major do not salute either time in passing the colors or the adjutant during the sound off.

(8) When the band has passed the left of the line of troops (or, if during a ceremony composed of an extremely long line of

troops, at a predetermined point after passing the adjutant) it executes a countermarch and returns over the same ground to the right of the line. When opposite its normal position on the right of the line of troops, the band executes a right turn, marches well to the rear of the line of troops and countermarches. When band reaches its proper position on the line the drum major, facing the band, gives the baton signal to halt.

(9) After the band has come to a halt, the drum major, still facing the band gives the signal to CEASE PLAYING and on the accented beat immediately following gives the signals for the second SOUND OFF. The three chords this time are played in the key of the particular part of the march just played. Upon the completion of the second sound off the drum major moves towards the right flank of the band, and takes the position two paces to the right of and on line with the front rank of the band, facing to the front. (See diagram, fig. 51.)

(10) Immediately after the second sound off the band leader instructs the sergeant bugler to SOUND RETREAT and takes his position in front of the band, facing to the front. (See (2) above and fig. 51.)

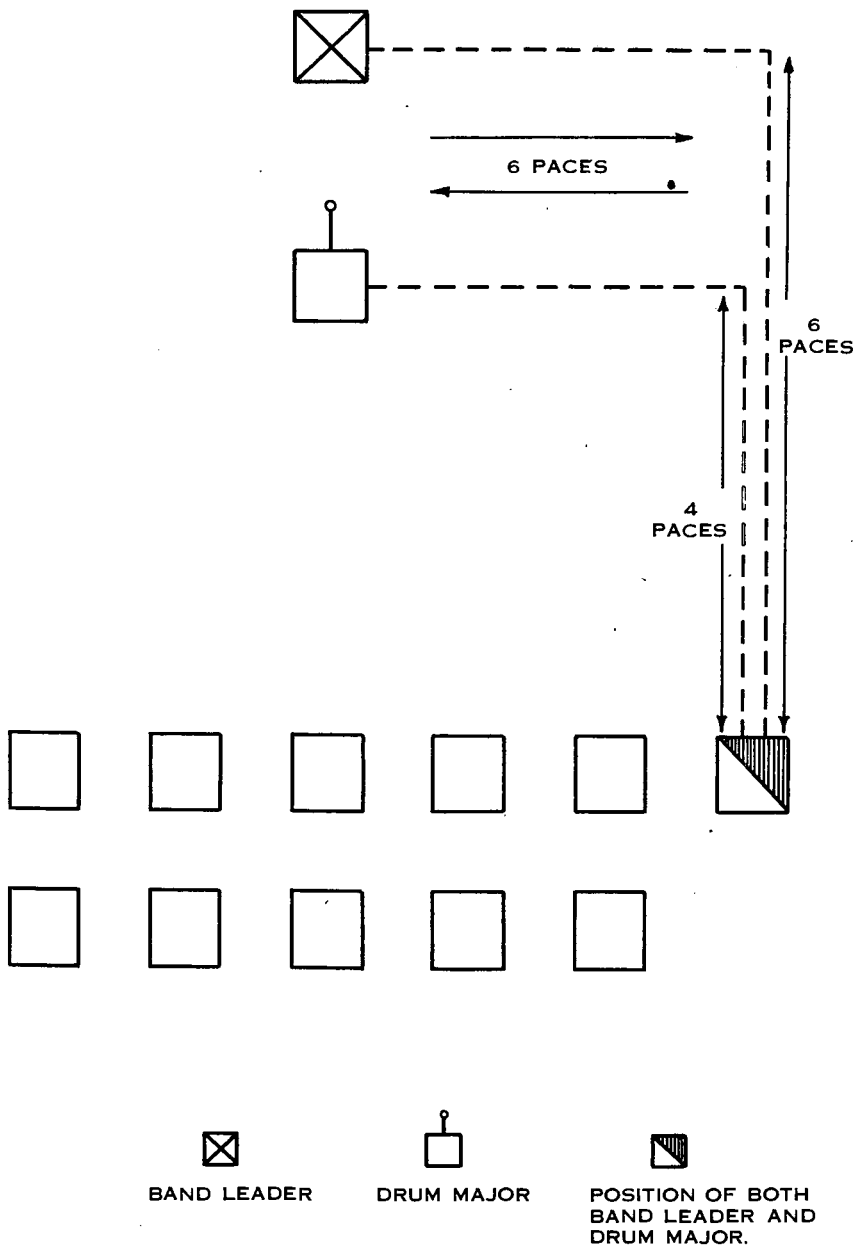
(11) The adjutant, upon the completion of RETREAT brings the command to ATTENTION and gives the command: 1. PRESENT, 2. ARMS.

(12) At the command PRESENT ARMS the drum major will come to PRESENT BATON and the band leader makes an about face preparatory to conducting the national anthem. When all troops have come to present arms, the band plays the national anthem.

(13) When a long line of troops are participating, it is practically impossible for the band leader to see when all troops have executed present arms. The band leader should wait until the adjutant salutes, this indicating all troops are at present arms. Upon the completion of the anthem the band leader will face to the front and salute.

(14) At the completion of the national anthem the adjutant terminates his salute and turns about, facing the battalion commander, salutes, and reports: "Sir, the parade is formed." The battalion commander directs the adjutant to take his post (1½ paces to the rear and 1 pace to the right of the battalion commander) and commands: 1. ORDER, 2. ARMS, and gives such movements in the manual of arms as he may desire.

(15) The band leader and the drum major terminate their salute at the command ORDER ARMS and return to their respective post, both facing the front. (See fig. 51.)



**FIGURE 51. POSTS AND CHANGING OF POSTS OF BAND LEADER AND DRUM MAJOR.**

(16) The battalion commander directs the adjutant to "receive the reports" whereupon the adjutant returns to his post midway between the battalion commander and the line of troops. From

this position he gives the command: REPORT. (The band leader does not report his organization.)

(17) After receiving the reports the adjutant faces the battalion commander and reports: "Sir, all present or accounted for."

(18) The battalion commander instructs the adjutant to PUBLISH THE ORDERS.

(19) After reading the orders for the day the adjutant commands: 1. OFFICERS, 2. CENTER, 3. MARCH. After giving the command march the adjutant takes his post with the battalion commander.

(20) The drum major upon the command: 1. OFFICERS, turns about facing the band.

(21) On the command: 2. CENTER, the drum major gives the baton signal for PREPARE TO PLAY.

(22) On the command: 3. MARCH, he gives the signal to COMMENCE PLAYING and turns about, facing the front. He remains in this position until the line of officers and guidons have marched up in front of the battalion commander, halted, and returned to the center of the line of troops. After officers have come to a halt in front of the battalion commander, band leader cuts volume of band, when the officers face about to return to their post band resumes normal volume.

(23) When the officers have arrived back on the line and are walking individually to their respective positions in line the drum major will face the band, give the baton signal to CEASE PLAYING to stop the band when the last officer has reached his position in line.

(24) The drum major then faces the front.

(25) The battalion commander gives the command: PASS IN REVIEW.

(26) At the command pass in review the band leader gives the command: BAND FORWARD (RIGHT TURN), MARCH. The band will not move forward until the command pass in review is given. (The band either moves forward and halts, or makes a right turn and halts depending on space available.)

(27) The band marches forward (without music) and halts as indicated in figure 52, far enough ahead of the leading unit of the parade that the interval between the band and the leading unit in passing in review will be approximately 18 paces.

(28) The band being at a halt, the drum major, facing the front will give the baton signal to PREPARE TO PLAY.

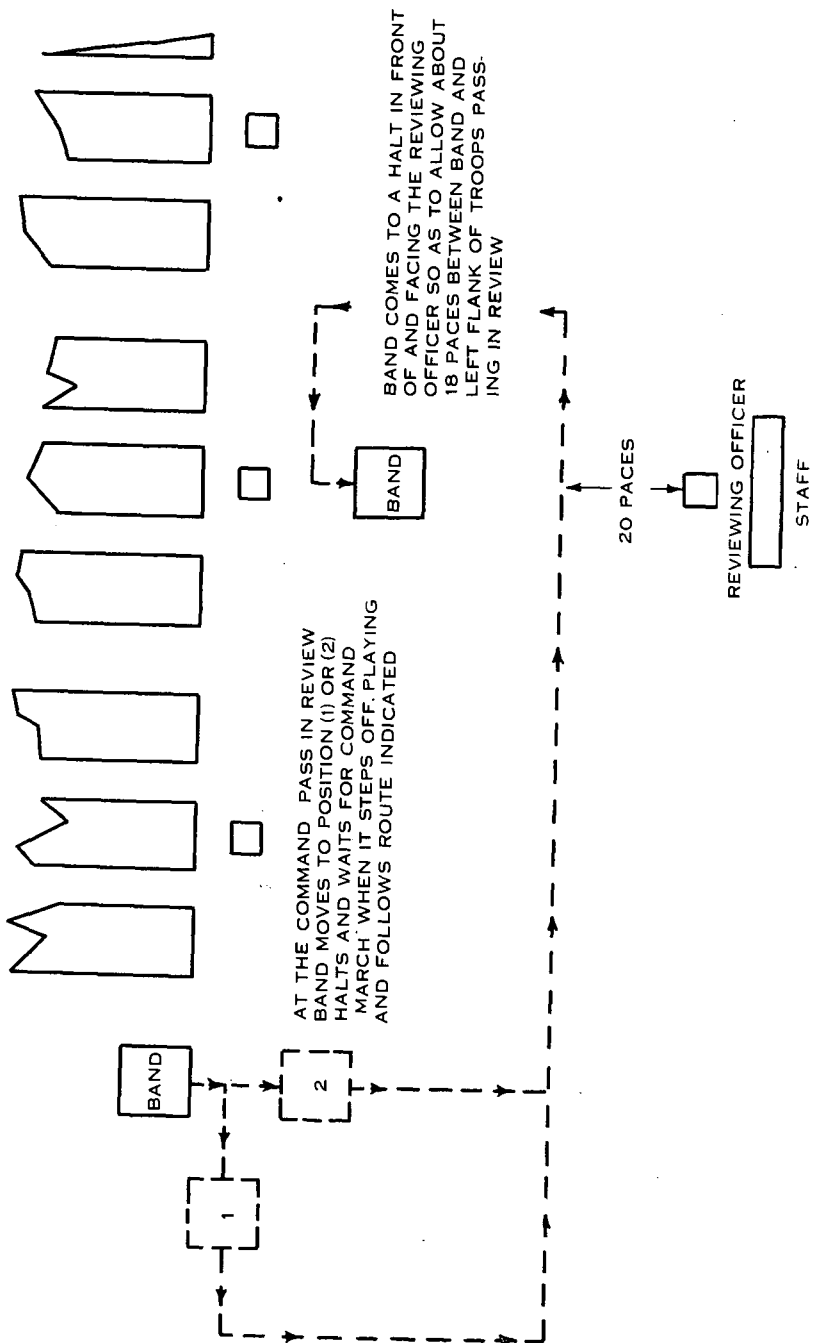


FIGURE 52. PASSING IN REVIEW.

(29) The drum major will give the signal **COMMENCE PLAYING** and start the band marching as the commander of the leading unit gives the command **MARCH**.

(30) The band will follow the route shown in figure 52 and the band leader and drum major will salute in manner prescribed for other commanders in passing the battalion commander.

(31) The band having passed the battalion commander makes three consecutive left turns to arrive at a position directly in front of the battalion commander and comes to a halt to leave a distance of 12 paces between the drum major and the left flank of the troops passing in review.

(32) The band leader and drum major salute when the colors pass the battalion commander.

(33) The band continues to play in front of the battalion commander until the last unit has passed when the drum major will give the signal for the band to march forward, make a left turn and follow the troops off the parade ground. The band leader and drum major do not salute in making the left turn in front of the battalion commander preparatory to marching off the field. When all troops are clear of the parade ground the band will cease playing.

**b. Regiment.** (1) Except for certain substitutions of terms, the procedure of the ceremony and the functions of the band are the same for a regimental special ceremonial parade as that prescribed for a battalion in (a) above.

(2) When an officer of a rank entitled to receive personal honors takes part in this ceremony the troops are presented to him after officers and guidons have returned from officers center. (See a (22) above.)

(3) Officers and guidons having returned to their positions on the line of troops (a(23) above) the commander of troops reverses his staff.

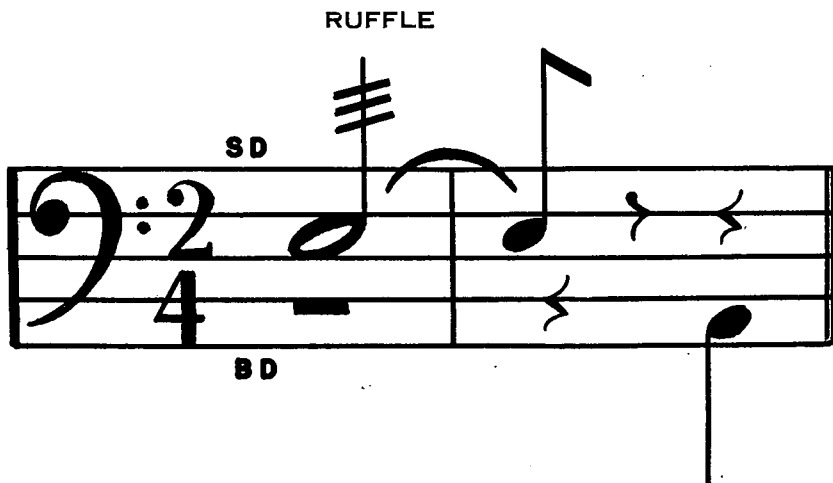
(4) The band leader and the drum major take their positions as prescribed in a(9) and (10) above.

(5) The commander of troops faces the line of troops and commands: 1. **PRESENT**, 2. **ARMS**. The drum major executes **PRESENT BATON**.

(6) When the commander of troops faces the reviewing officer and salutes, the band plays the prescribed musical honors (AR 600-25).

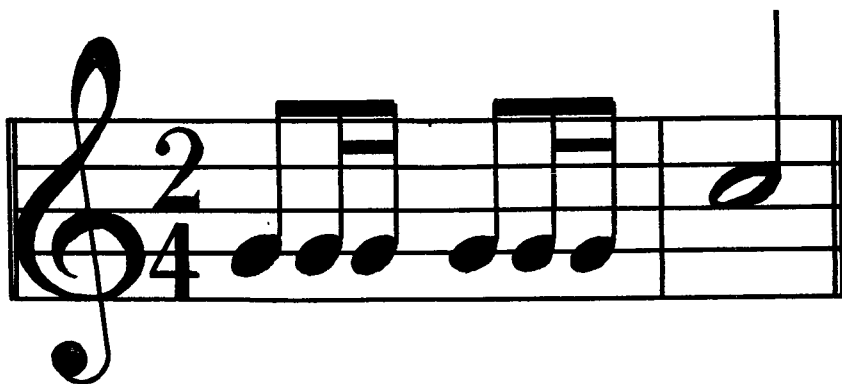
(7) At the conclusion of the honors the band leader faces the front and salutes.





PLAYED BY SNARE AND BASS DRUMS  
(AS INDICATED) SIMULTANEOUSLY WITH  
THE RENDITION OF FLOURISHES.

FLOURISH



PLAYED BY FIELD MUSIC. MAY ALSO BE  
(PLAYED IN UNISON BY ALL BRASS  
INSTRUMENTS OF BAND.)

FIGURE 53. RUFFLES AND FLOURISHES.

(8) The band leader and drum major remain in this position until the command ORDER ARMS when they terminate their salute and resume their normal position on the right flank and in front of the band respectively. (See fig. 51.)

(9) Ceremony proceeds as described in a(26) to (31) above, inclusive.

(10) The band, having halted in front of the reviewing officer, continues to play until the colors approach the reviewing officer, when the drum major will give the proper baton signals to accomplish the following:

(a) As the colors approach the reviewing officer he will give the signal to PREPARE TO CEASE PLAYING.

(b) As the colors "dip" in salute he will give the signal to CEASE PLAYING and on the next accented beat signal the band to COMMENCE PLAYING when the band will play the prescribed ruffles and flourishes. (See fig. 53.) The Generals' March is not played while troops are passing in review.

(c) At the completion of the honors the drum major again starts the band playing the march, beginning at a place previously announced by the band leader (either going back to the beginning or to the trio). The drum major then faces to the front.

(d) The band leader salutes during the rendition of the honors.

(11) If field music is present during this ceremony the following procedure will be followed in lieu of instructions given in (10) above.

(a) When colors approach the reviewing officer the sergeant bugler will instruct the field music to PREPARE TO PLAY.

(b) As colors "dip" in salute he will give the proper signal to the field music to COMMENCE PLAYING and render the prescribed ruffles and flourishes. (See fig. 53.) The band continues to play without regard to the field music. Band leader and drum major both salute when field music render the honors.

(12) The band continues to play in front of the reviewing officer until the last element of the parade has passed when the drum major will give the proper baton signals to move the band forward, playing, following the troops off the field. No salute is rendered as the band is making the left turn in front of the reviewing officer in following the troops.

**124. RETREAT PARADE.** a. Troops are formed in the manner prescribed in paragraph 123a(1) to (4) inclusive, for special ceremonial parade.

b. After the adjutant has posted the guides he will give the command: 1. PRESENT, 2. ARMS.

c. When all troops have come to present arms he commands: SOUND RETREAT (or signals the band leader to that effect).

d. The band leader instructs the sergeant bugler to SOUND RETREAT. (See par. 123a(10).)

e. The band leader and drum major at this time take their positions as described in diagram in figure 51. The band leader faces the band.

f. Upon the completion of RETREAT the band leader conducts the band in the national anthem. If ceremony is held on a military reservation where an evening gun is used, the band leader will wait until the gun is fired at the conclusion of retreat before playing the anthem.

g. The drum major comes to BATON SALUTE at the first sound of the anthem.

h. At the conclusion of the anthem the band leader will face to the front and salute.

i. The adjutant terminates his salute at the end of the anthem, makes an about face and salutes the battalion commander reporting: "Sir, the parade is formed." He is then instructed to take his post. (See par. 123a(14).)

j. The battalion commander gives the command: 1. ORDER, 2. ARMS.

k. At this point, procedure depends entirely upon the officer personnel involved. If a battalion or regimental commander is reviewing his own troops, he will at this point give the orders to PASS IN REVIEW, and ceremony proceeds as outlined in paragraph 123a(25) to (33), inclusive.

l. If a staff officer has been designated as the commander of troops, he will, after the troops have been presented to him upon the conclusion of the national anthem, give the command: ORDER ARMS.

m. The parade now proceeds as described in paragraph 123b(5) to (12), inclusive.

**125. STREET PARADE.** a. For street parade the troops are formed in the most convenient manner.

b. The band leader will obtain necessary information as to the length of parade, etc., to be able to prepare a program of marches to be played.

c. Prior to the start of the parade music will be announced and each individual instructed to arrange his music in a convenient manner. Band leader should announce how the marches are to be played, that is, once through, or twice through, with drums or field music, alternating. No verbal instructions should be necessary once the parade has begun.

d. If field music is available it is customary to have them alternate with the band thus giving the band a chance to rest and at the same time affording music throughout the entire line of march.

e. During parades when persons entitled to personal honors are present in the reviewing stand the following instructions will govern:

(1) When only one band is participating, and space permits, the band should turn (right or left) out of line of march after passing the reviewing stand, countermarch and halt on line with the reviewing stand.

(2) When colors approach the reviewing officer the band will render the prescribed ruffles and flourishes in the manner prescribed in paragraph 123b(10) and (11).

(3) Band continues to play until all troops have passed, when it will move forward and join the line of march.

(4) When a number of bands are participating and space will permit, one band will be designated to turn out of line as described in (1) above. This band will sound all honors, and will play martial music for troops only when other bands in the parade cannot be heard.

(5) When space does not permit the band to turn out of line after passing the reviewing officer and honors are to be rendered, the drum major will give the proper baton signals to accomplish the following:

(a) When approximately 8 paces from the reviewing stand he will give the proper baton signal to **PREPARE TO CEASE PLAYING**.

(b) When 6 paces from the reviewing officer he will give the signal to **CEASE PLAYING** and on the next accented beat signal the band to **COMMENCE PLAYING** when the band will play the prescribed ruffles and flourishes. (The Generals' March is not played as part of these honors. (See par. 123b(10)(b).)

(c) At the conclusion of honors the drum major will again start the band playing the march as previously announced by the band leader.

f. Personnel of the band should be instructed when to expect the signal for the rendition of the honors and whether or not the band is to turn out of line after passing the reviewing stand. The more detailed information that can be given the entire band as to the procedure of the parade will contribute greatly to the success of the entire performance.

## Section II. REVIEWS

126. REVIEW. a. The band forms for a review in the same manner as for a parade (par. 123a(1)) and procedures outlined in paragraph 123a(1) to (4), inclusive, are equally applicable to a review.

b. The adjutant, after posting the guides and having taken his post between the battalion commander and the line of troops, gives the command: 1. **PRESENT**, 2. **ARMS**.

- c. The band leader and drum major salute.
- d. The adjutant having faced about salutes the commander of troops and reports: "Sir, the review is formed."
- e. The commander of troops returns the salute and directs the adjutant to take his post (par. 123a(14)) and gives the command: ORDER ARMS (and gives the order for REST or AT EASE).
- f. If honors are to be rendered, the band leader and drum major terminate their salute and take their positions as described in diagram in figure 51, otherwise they terminate their salute and remain in their normal positions.
- g. The reviewing officer having arrived, the commander of troops reverses his staff and facing the troops commands: PRESENT ARMS.
- h. After all troops have come to present arms, he faces the reviewing officer and salutes.
- i. If reviewing officer is entitled to honors the band leader will take the commander of troops' salute as a signal to render the prescribed musical honors.
- j. Honors completed, the band leader faces the front and salutes. Band leader and drum major terminate their salute on the command ORDER ARMS given by the commander of the leading battalion. The band leader remains in front of the band.
- k. The reviewing officer joins the commander of troops preparatory to inspecting the troops and the band leader will conduct the band in the playing of music selected for the inspection.
- l. As the inspecting party starts their inspection on the right flank of the band, the band leader will face to the front (band still playing) and remain in this position until the party has passed the left flank of the band. Band leader and drum major do not salute and do not execute eyes right.
- m. After the inspecting party passes the band, the band leader will again face the band and continue conducting. The band will continue to play until the inspection is completed, the party having separated by the right flank of the band and returned to their original positions. After stopping the band, the band leader and drum major return to their normal positions on the right flank and in front of the band, respectively.
- n. The commander of troops will now give the command to PASS IN REVIEW and the ceremony precedes as described in paragraph 123a(26) to (31) and paragraph 123b(10) to (12), inclusive.

**127. RETREAT REVIEW.** a. When a review is held at the usual time of retreat, as soon as the troops have been presented to the commander of troops and the adjutant has taken his post (par.

123a(14)), the commander of troops commands: SOUND RETREAT (or gives a signal to the band leader to that effect).

b. The band leader will instruct the sergeant bugler to SOUND RETREAT (par. 123a(2)) and take his post in front of the band. The drum major takes his post on the right flank of the band. (See fig. 51.)

c. If ceremony is held on a military reservation where an evening gun is used, the national anthem should not be played until the gun has been fired at the conclusion of retreat. The drum major assumes the position of PRESENT BATON at the first sound of the anthem.

d. At the completion of the anthem the band leader will face the front and salute.

e. The band leader and drum major terminate their salute on the command ORDER ARMS and remain in their positions in front of and on the right flank of the band, respectively.

f. The commander of troops having brought the troops to ORDER ARMS reverses his staff and ceremony proceeds as described in paragraph 126 e to n, inclusive.

### Section III. PRESENTATION OF DECORATIONS

**128. GENERAL.** a. Decorations are usually presented during the course of some other ceremony. Inasmuch as the ceremony of presentation of decorations requires the rendition of the national anthem, it is not advisable to include presentations in a retreat parade or retreat review which ceremonies in themselves require the playing of the national anthem. Should the ceremony of presentation of decorations be included as part of a retreat parade or retreat review it is recommended that To the Color be played in lieu of the national anthem during the retreat ceremony to avoid playing the national anthem more than once during the ceremony as a whole.

b. At a ceremony of presentation of foreign decorations the national anthem of the country awarding the decorations will be played at the proper time (par. 129a(10)) and will be followed immediately by the playing of The Star-Spangled Banner.

**129. PRESENTATION OF DECORATIONS.** a. **As part of parade.** (1) Troops are formed in the manner prescribed in paragraph 123a(1) to (4), inclusive.

(2) After posting the guides, the adjutant brings the troops to PRESENT ARMS and presents them to the commander of troops.

(3) The commander of troops directs the adjutant to take his post (par. 123a(14)) and gives the troops ORDER ARMS. The

band leader and drum major take their position as indicated in diagram in figure 51.

(4) Having reversed his staff the commander of troops presents the command to the reviewing officer (par 126g and h) and the band renders the prescribed honors. (See par. 126i and j.)

(5) Upon the completion of the honors the commander of troops terminates his salute, faces the command and orders ORDER ARMS and AT EASE. The band leader and drum major remain in front of and on the right flank of the band respectively.

(6) The troops being at ease the commander of troops commands: 1. PERSONS TO BE DECORATED AND ALL COLORS, CENTER, 2. MARCH.

(7) On the preparatory command in (6) above, the band leader faces the band and on the command in (2) above MARCH starts the band playing a march. The band continues to play until the persons to be decorated have arrived in front of the reviewing officer and come to a halt when it will cease playing.

(8) The commander of troops reports the detachment to the reviewing officer and is instructed to bring the command to PRESENT ARMS.

(9) Having returned to his post in front of the center of the command the commander of troops gives the command: PRESENT ARMS. When all troops have come to present arms he turns about and salutes. The drum major comes to PRESENT BATON. (See par. 123a(12).)

(10) The band leader, from his position in front of the band, conducts the band in the national anthem as soon as the persons to be decorated and all colors execute present arms.

(11) Upon the completion of the anthem the band leader will face about and salute. Band leader and drum major terminate their salute on the command ORDER ARMS.

(12) At the conclusion of the presentation ceremonies it is customary for the colors to return to their normal position in the line of troops without music, in which case the band leader and drum major return to their normal positions on the right flank and in front of the band, respectively. Should instructions have been given the band leader to furnish music while the colors return to their position in the line of troops the band will start playing when the colors turn about preparatory to marching to their normal position in the line of troops. In this case the band will continue to play until the colors have halted in their proper position on line.

(13) The commander of troops gives the command to PASS IN REVIEW and ceremony proceeds as described in paragraph 123a (26) to (31), inclusive, and, if applicable, in paragraph 123b(10) to (12), inclusive.

**b. As part of review.** (1) Procedure for this ceremony is identical with instructions given in paragraph 126a to m, inclusive, except that the band leader and drum major, after the reviewing party has completed its inspection of the troops (par. 126m), remain in their positions in front of and on the left flank, respectively.

(2) After the troops have been inspected by the reviewing officer (par. 126l) and the reviewing party has returned to their original position (par. 126m) the commander of troops, from his position in front of the center of the line of troops, causes the troops to come to attention and commands: 1. PERSONS TO BE DECORATED AND ALL COLORS, CENTER, 2. MARCH.

(3) Ceremony now proceeds as outlined in paragraph 129a (7) to (13), inclusive.

#### Section IV. ESCORTS

**130. GENERAL.** **a.** Procedure for these ceremonies depends largely on the physical set-up of the place where the distinguished personage is to be received. The purpose of the ceremony is nevertheless, in either case the same, namely, to pay tribute to a distinguished personage by means of an honorary guard and by rendering the musical honors due his rank. (See AR 600-25.)

**b.** There are two distinctive ways in which this ceremony may be performed. If a personage is received at one point and is to be escorted by means of marching to another point the ceremony is usually referred to as an "escort of honor." Should the band and honor guard (escort) be directed to form at a designated place to receive a distinguished personage without being required to escort the personage to any other place the ceremony is referred to as a "guard of honor."

**131. ESCORT OF HONOR.** **a.** The escort forms in line opposite the place where the personage is to present himself. The band forms on line with and on the flank of the escort toward which the procession is to march. The band leader gives all verbal commands to the band unless otherwise stated in these instructions.

**b.** After the drum major has checked the alignment of the band he will take his position on the right flank of the band. (See par. 123a (9).) The band leader takes his post in front of the band.

**c.** Upon the appearance of the personage the commander of the escort (hereafter referred to as the commander) will bring the escort to attention. The band will take this command from the commander. The band leader remains facing the front.



d. When the personage has taken his position in front of the commander the commander makes an about face, facing the troops and commands: 1. PRESENT, 2. ARMS. The drum major executes PRESENT BATON.

e. The band leader turns about, facing the band and gives a signal to prepare to play the honors (he does not salute). Music to be used should have been thoroughly explained and the rotation of numbers to be used checked.

f. After the escort has executed PRESENT ARMS the commander will face the personage and salute. The band leader will watch the commander and will start the band playing the prescribed honors at the instant the commander comes to hand salute (or present saber, if so armed).

g. After the honors are completed the band leader faces the front and salutes.

h. Upon the completion of the honors the commander makes an about face and commands: 1. ORDER, 2. ARMS. The band leader and drum major terminate their salute.

i. The escort is usually inspected at this time and the inspection is accomplished by the personage, accompanied by the commander, walking around the band and honor guard starting from a position in front of and on the right flank of the band.

j. As soon as it is apparent that the escort is to be inspected the band leader will face the band and start the band playing the music selected for this purpose. In this connection it is pointed out that the number to be used should be carefully selected. Usually an ordinary march is played, but some commanding officers prefer to have some other type of music played for this purpose, the idea being that the playing of a march instills the martial spirit in the inspecting party causing them to walk briskly in tempo with the music, paying little or no attention to the troops. However, unless specifically instructed to the contrary, it is safe to select a march which should be played in a musical manner stressing dynamics wherever possible. The band leader should bear in mind that there is likely to be considerable discussion between personage and the commander in regards to troops and individual soldiers, therefore, the music never should be too loud.

k. After having started the band playing the inspection number the band leader will turn about and face the front. He will remain facing the front until the personage has passed by the band then he will resume conducting the band. Band leader does not salute.

l. The band will continue to play until the inspecting party has passed in back of the band and is returning to their normal posi-

tions in front of the escort. After stopping the band from playing the band leader will remain in front of the band.

m. The commander will, from his position in front of the escort, give the command: 1. PRESENT, 2. ARMS, face the personage and salute. (See d and f above.)

n. The band renders the prescribed honors when the commander salutes as in f above.

o. After the honors are completed the band leader will turn about and salute.

p. At the command ORDER ARMS given by the commander the band leader and drum major terminate their salute and take their positions on the right flank and in front of the band, respectively. (See fig. 51.)

q. The band leader will give the necessary verbal commands to move the band into the proper position (right or left turn) without playing. When the band is in proper position it will come to a halt.

r. After the band has been halted the drum major will give the baton signal to PREPARE TO PLAY AND MARCH.

s. The commander will give the preparatory commands to form the escort for the march and will wait until the band is in position and has come to a halt (r above) before giving the command: 1. FORWARD, 2. MARCH.

t. On the command MARCH the drum major gives the baton signal to COMMENCE PLAYING AND MARCHING and follows the route of march to the designated place where the personage is to be taken.

u. When the band and escort arrive at the designated place, they come to a halt and form in line as described in a and b above.

v. When the personage dismounts from the vehicle and takes his position in front of the commander the escort is brought to PRESENT ARMS as in d above.

w. The band renders the honors due in the same manner as described in e and f above. The band leader upon the completion of the honors turns about and salutes. (See g above.)

x. The escort is not inspected at this time. Order arms is given by the commander and the troops and band remain at attention until personage is out of sight.

y. Prior to the personage leaving, the commander will receive instructions (usually from the staff officer detailed to accompany the personage) to dismiss the escort or remain in place in order to escort the personage back to the place where he was received.

z. If escort is dismissed the troops are marched away with the

band playing and the drum major taking the command march from the commander.

**aa.** If escort is instructed to remain the troops are given **REST** or **AT EASE**. The band plays a program of selected music until such time as the personage reappears. (If band has to be moved to the opposite flank of the escort in order to later march the escort back to the place the personage was originally received, these details will be taken care of at this time.)

**ab.** The commander will call the escort to **ATTENTION** when the personage appears and when the personage has taken his position in front of the escort the troops will be brought to **PRESENT ARMS** as prescribed in d above.

**ac.** Band sounds the honors as in f and g above and upon the completion of the music the commander will give the command: 1. **ORDER**, 2. **ARMS**. (See h above.)

**ad.** The escort is not inspected at this time and ceremony now proceeds as outlined in p to x above, inclusive, except that personage is this time escorted back to the place where he was originally received.

**ae.** The personage having taken his leave, the escort is marched to their barracks with the band playing.

**132. GUARD OF HONOR.** **a.** This ceremony is held when a distinguished personage is to be received at a designated place and instructions have been received that personage is not to be escorted. (See par. 130b.)

**b.** The escort is formed in line opposite the place the personage is to present himself. The band forms on line with and on the right flank of the escort.

**c.** After the drum major has checked the alignment of the band he takes his post on the right flank of the band. (See fig. 51.) The band leader takes his position in front of the band.

**d.** Ceremony proceeds as outlined in paragraph 131 b to o, inclusive.

**e.** The commander, after giving the command **ORDER ARMS** will face the front and will at this time receive instructions (from staff officer detailed to accompany personage) to dismiss the escort or remain in position to render the prescribed honors upon the departure of the personage.

**f.** If the escort is dismissed, the troops are marched to their barracks with the band playing. (See par. 131z.)

**g.** If escort is instructed to remain, the troops are given **REST** or **AT EASE** and the band plays appropriate music.

**h.** As personage reappears the commander will call the escort to **ATTENTION** and when the personage has taken his position in

front of the escort the commander will give the command: 1. PRESENT, 2. ARMS and the band renders the musical honors. (See par. 131d to g.)

i. The honors completed, troops are given ORDER ARMS and the personage takes his leave whereupon the escort is marched to their barracks with the band playing.

**133. ESCORT TO THE COLOR.** a. Preliminary procedures for this ceremony are identical with those outlined in paragraph 123a (1) to (4), inclusive.

b. After having posted the guides, the adjutant signals to the band leader to move the band into position to march the designated company (escort) to the place where the national color is to be received.

c. The band moves forward, without music, until it has cleared the line of battalion commanders, changes direction if necessary, and halts.

d. The escort forms in column of threes or fours 15 paces behind the band. At the command: 1. FORWARD, 2. MARCH, given by the escort commander, the escort marches, without music, to the regimental or post commander's office or quarters and forms in line facing the entrance. The color bearer, preceded by the senior lieutenant and followed by a sergeant of the escort, obtains the color.

e. If the band has to change position to be on the flank of the escort towards which it is to march, the band leader will cause the band to move at this time. When the band is in the proper position, the band leader will give the command: 1. RIGHT (or LEFT), 2. FACE to have the band facing towards the entrance. The band leader will take his position in front, facing the band. The drum major executes right or left face with the band and marches forward to be on line with the new front rank of the band.

f. When to color is brought out and is in position in front of the escort, the escort commander, facing the troops will give the command: 1. PRESENT, 2. ARMS, turn about and salute the color. The drum major executes PRESENT BATON.

g. The band leader will cause the field music (or the trumpet section of the band (par. 123a (2))) to sound To the Color. Upon the completion of the music he will turn about and salute.

h. At the completion of To the Color the escort commander will terminate his salute, face the troops and give the command: 1. ORDER, 2. ARMS.

i. The band leader and drum major terminate their salute on the command ORDER ARMS. The band leader gives the command:

1. RIGHT (or LEFT), 2. FACE and returns to his normal position on the right flank of the band.

j. After the band leader reaches his position on the right flank of the band, the drum major will give the baton signal to PREPARE TO PLAY AND MARCH.

k. The escort commander having formed the escort in column, 15 paces in rear of the band will give the command: 1. FORWARD, 2. MARCH and the drum major will take this command to set the escort in motion.

l. The escort is now marched back to where the troops are formed with the band playing. The escort is marched to a point approximately 50 paces in front of the right of the line of troops and then marches parallel to the line of troops. The regimental commander has taken his position 30 paces in front of the line of troops.

m. The drum major gives the baton signal to CEASE PLAYING when directly opposite the regimental commander, (this is done in order for the band to be able to hear the command HALT, given by the escort commander).

n. When the national color is directly opposite the regimental commander the escort commander commands: 1. ESCORT, 2. HALT and forms the escort into line, facing the regimental commander.

o. Immediately after coming to a halt the band leader will give the command: 1. RIGHT (or LEFT), 2. FACE so that the band will face towards the line of troops. The band leader will take his position in front of and facing the band. The drum major executes right or left face with the band and marches forward to be on line with the new front rank of the band. Upon reaching his new position the band leader will give the signal to the field music (par. 123a(2)) to prepare to play.

p. The regimental commander, facing the line of troops gives the command: 1. PRESENT, 2. ARMS, faces the color and salutes. The drum major executes BATON SALUTE.

q. The band leader will cause the field music to sound To the Color at the instant the regimental commander salutes. The band leader will face the front and salute at the completion of To the Color.

r. Upon the completion of To the Color the regimental commander will face the troops and command ORDER ARMS. The band leader and drum major terminate their salute and the band leader, facing the band will give the command: 1. RIGHT (or LEFT), 2. FACE and return to his normal position on the right flank of the band.

s. After the band has executed the necessary right or left face,

the drum major, having taken his normal position in front of the band will give the proper baton signal to PREPARE TO PLAY AND MARCH.

t. The escort commander having formed the escort into column will give the command: 1. FORWARD, 2. MARCH and the drum major will set the escort in motion.

u. Escort and band are marched around the left end of the line of troops and the band continues to play until the escort has passed the left of the troops. The drum major will give the baton signal to CEASE PLAYING and the band continues the march in rear of the line of troops until it is opposite its original position in line when it makes a left turn and comes to a halt on line with the line of troops.

v. The drum major checks the alignment of the band and ceremony proceeds as directed (parade or review).

**134. FUNERAL ESCORTS.** a. General. (1) Military funerals are divided into three classes, namely:

(a) With chapel service followed by march to the grave (or place of local disposition) with the prescribed escort.

(b) Without chapel service, but with funeral procession forming at the entrance to the cemetery or at a point within a reasonable marching distance from the grave.

(c) With graveside service only.

(2) Whenever arms are presented at a military funeral of a person entitled to personal honors, the prescribed ruffles and flourishes followed by the anthem or march as prescribed for the individual (AR 600-25) will be sounded except when arms are presented at the close of the benediction at the graveside service.

(3) The word "chapel" as used herein is interpreted to include the church, home, or other place where services are held exclusive of the service at the grave.

(4) The word "casket" is interpreted to include the receptacle containing the cremated remains of the deceased.

(5) The march from the chapel to the grave is made at a cadence of from 60 to 80 steps per minute. If the distance between the chapel and grave is extremely great, the escort, while the band is not playing, may be instructed to march in quick time or 120 steps per minute until within a reasonable distance from the grave when the escort will resume the slower step and the band will again start playing. This change of tempo should be accomplished by means of the percussion section gradually increasing or decreasing the tempo. The band leader will give necessary instructions to the band and the commander of the escort so that this procedure is thoroughly understood. The escort

should always start the procession by marching in the slow tempo to music.

(6) The shell of all drums, both snare and bass, will be completely covered with black crepe. Snare drums will be muffled. Cymbals should not be used indiscriminately, if at all. It is suggested they be dispensed with and that a Chinese gong of good quality be used instead.

(7) The drum major's baton will have a large bow of black crepe tied where ball joins the staff. All movements of the drum major's baton will be executed in a precise and dignified manner without flash or flourish. The baton is never twirled during a funeral. The drum major does not mark cadence while band is marching and playing. The baton is habitually carried under the right arm as in carry baton with the left hand grasping the wooden staff from the back, waist high, back of hand to body. The whistle is never used during a military funeral.

(8) Local conditions will naturally necessitate changes in procedure outlined for the following ceremonies. It is advisable for the band leader to confer with the officer in charge of arrangements prior to the time set for the actual ceremony. So far as practicable the following instructions will govern.

**b. With chapel service** (see a (1) (a) above). (1) Prior to the time set for the service, the escort forms in line opposite to and facing the chapel and the band on the flank towards which it is to march.

(2) When the conveyance bearing the remains approaches, the escort and band will be brought to ATTENTION.

(3) The conveyance comes to a stop directly in front of the entrance to the chapel and attendants make the necessary preparations to move the casket into the chapel.

(4) The moment that the casket bearers lift the casket from the conveyance the escort is brought to PRESENT ARMS. The drum major executes PRESENT BATON.

(5) If the rendition of honors is required (a(2) above) they will be sounded as the escort executes present arms. Upon completion of the honors the band plays a hymn or sacred song. If no honors are required the band will start playing the hymn or sacred song as the escort executes present arms. The band continues to play until the casket has been carried into the chapel. Careful judgment on the part of the band leader is essential in stopping the band during the rendition of the hymns in a ceremony of this type. A hymn should always be played thru to its completion. If this is not possible, the volume of the band should be gradually decreased and a stop made at the end of a phrase, preferably ending on the tonic. After casket is carried

into the chapel and the band has ceased playing, escort is given **ORDER ARMS** and escort and band given **REST** or **AT EASE**.

(6) Escort and band are brought to attention at the conclusion of the chapel service and as the casket comes into view escort is given **PRESENT ARMS**. At this command the drum major executes present baton and band leader starts the band playing a hymn or sacred song. The band continues to play until the casket is placed in the conveyance.

(7) If necessary, the band will change direction to be in position to lead the procession.

(8) The procession is formed as follows:

(a) The band.

(b) Escort, including colors, firing party, and bugler.

(c) Clergy.

(d) Caisson (or conveyance) and honorary pallbearers, if walking.

(e) Casket bearers.

(f) Caparisoned horse, if deceased was mounted.

(g) Honorary pallbearers, if riding in cars.

(h) Family.

(i) Patriotic and fraternal organizations.

(j) Friends.

(9) When the procession has been formed, the escort commander gives the command: 1. **IN SLOW CADENCE**, 2. **FORWARD**, 3. **MARCH**. The drum major gives the baton signals: 1-2. **PREPARE TO PLAY**, 3. **COMMENCE PLAYING AND MARCHING**.

(10) The procession marches over the prescribed route. Band and escort will form in line facing the grave. It is customary for the band to cease playing prior to taking its place in line at the grave as the band usually has to walk over sidewalks, gutters, and other obstacles in order to reach its proper position in line. After checking the alignment of the band, the drum major will take his post on the right flank of the band.

(11) The band and escort being in line, the commander of the escort will give the command **PRESENT ARMS** when the casket is removed from the conveyance. The drum major executes present baton.

(12) When the escort has executed present arms, the band leader having taken his post in front of the band, will start the band playing a hymn or sacred song ((5) above). If honors are required (a(2) above) they will be sounded immediately prior to the playing of the hymn.

(13) The band continues to play until the casket is in place over the grave when the escort commander will bring the escort



to **ORDER ARMS** and command: **PARADE REST**. The drum major executes order baton and the band remains at **ATTENTION**.

(14) At the conclusion of the service the escort commander gives the command: 1. **ESCORT, LESS FIRING PARTY**, 2. **PRESENT**, 3. **ARMS**, 4. **FIRING PARTY**, 5. **FIRE THREE VOLLEYS**.

(15) At the command **PRESENT ARMS** the band leader and drum major salute. Honors, if required, are not sounded at this time. (See a(2) above.)

(16) The bugler designated to sound **TAPS** takes his position at the head of the grave on the command **PRESENT ARMS**. He does not salute. Immediately after the three volleys he will play **TAPS** after which he salutes, does an about face and assumes his normal position with the escort.

(17) At the conclusion of **TAPS** the escort commander gives the command **ORDER ARMS** after which the escort and band is put in march in quick time by the commander of the escort. No music is played while band and escort are still within the cemetery. When outside the limits of the cemetery it is discretionary with the officer in charge of arrangements as to the band playing while marching the escort to its quarters.

**c. Without chapel service** (see a(1) (b) above). (1) For this ceremony the band and escort form in line opposite the entrance to the cemetery or at a point within a reasonable walking distance from the grave with the band on the flank towards which it is to march.

(2) As the conveyance bearing the remains approaches, the escort and band are brought to attention. If circumstances require the casket to be transferred from one conveyance to another the escort commander will give the command **PRESENT ARMS** and the band will play a hymn or sacred song as outlined in b(6) above. If honors are required they will be sounded immediately prior to the rendition of the hymn. (See a(2) above.) If casket is not transferred, music is not required and the escort is not presented.

(3) Procession is now formed as outlined in b(8) above and ceremony proceeds as prescribed in b(7) to (17) above, inclusive.

**d. With graveside service only** (see a(1)(c) above). (1) For this ceremony the band and escort form in line at the grave as prescribed in b(10) above, and ceremony is conducted in manner outlined in b(11) and (17) above.

(2) If the family of the deceased desires to eliminate all unnecessary elements, the following are sufficient to properly conduct the ceremony:

- (a) Clergy.
- (b) Casket bearers.
- (c) Firing party.
- (d) Bugler.

## Section V. FORMAL GUARD MOUNT

**135. GENERAL.** a. The band takes its place on the parade ground so that the left of its front rank is 12 paces to the right of the point where the right of the front rank of the guard is to be when formed. (See fig. 54.)

b. Upon a signal from the adjutant the field music will sound the adjutant's call. (See par. 123a(2) (3) and (4).)

c. The band having ceased playing after the guard has come up on line remains at attention until the officer commanding the guard commands PREPARE FOR INSPECTION when the band leader and drum major will take their positions in front of and on the right flank of the band, respectively. (See fig. 51.)

d. The band leader from his position in front of the band conducts the band in a program of popular music until the inspection is completed and the inspecting officer is returning to his position in front of the guard. The band is not inspected during a formal guard mount.

e. The band leader and drum major resume their normal positions on the right flank of and in front of the band after the band has ceased playing.

f. The adjutant from his position 36 paces in front of and facing the guard gives the command: 1. PARADE, 2. REST, 3. SOUND OFF.

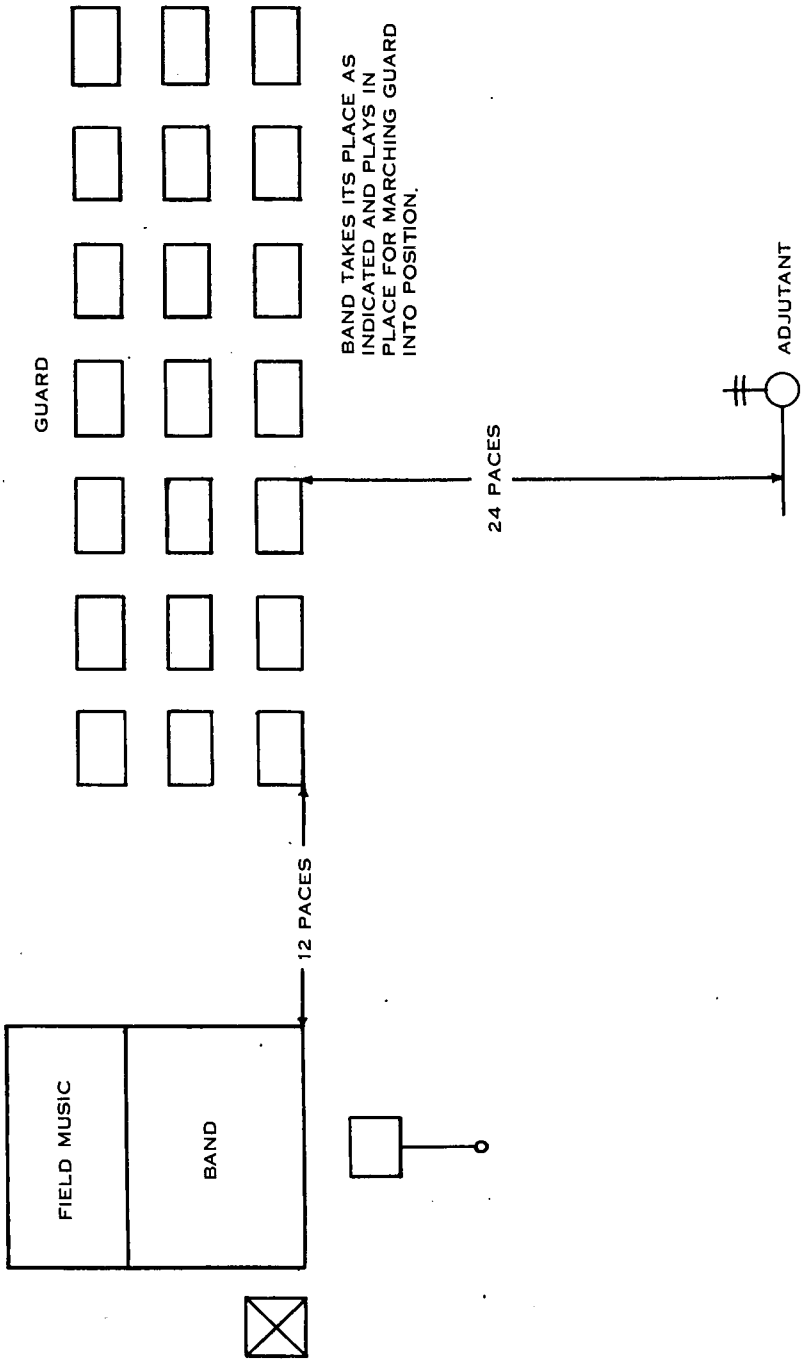
g. On the command SOUND OFF the band executes the movements prescribed in paragraph 123a(6) to (9), inclusive. (See fig. 55.)

h. After the second sound off (par. 123a(9)) the drum major faces the front and assumes the position of ORDER BATON.

i. The adjutant comes to attention and commands: 1. GUARD, 2. ATTENTION, 3. CLOSE RANKS, 4. MARCH. The ranks having been closed, the adjutant commands: 1. PRESENT, 2. ARMS, faces the new officer of the day, salutes and reports the guard. The new officer of the day returns the salute and directs the adjutant to "march the guard to its post" or "march the guard in review."

j. If the adjutant is instructed to "march the guard to its post" he faces the guard and repeats the command and the band and field music are dismissed.

k. If the adjutant is instructed to "march the guard in review" he brings the command to order arms and commands: 1. PASS IN REVIEW, 2. RIGHT, 3. FACE.



BAND TAKES ITS PLACE AS INDICATED AND PLAYS IN PLACE FOR MARCHING GUARD INTO POSITION.

FIGURE 54. FORMAL GUARD MOUNT.

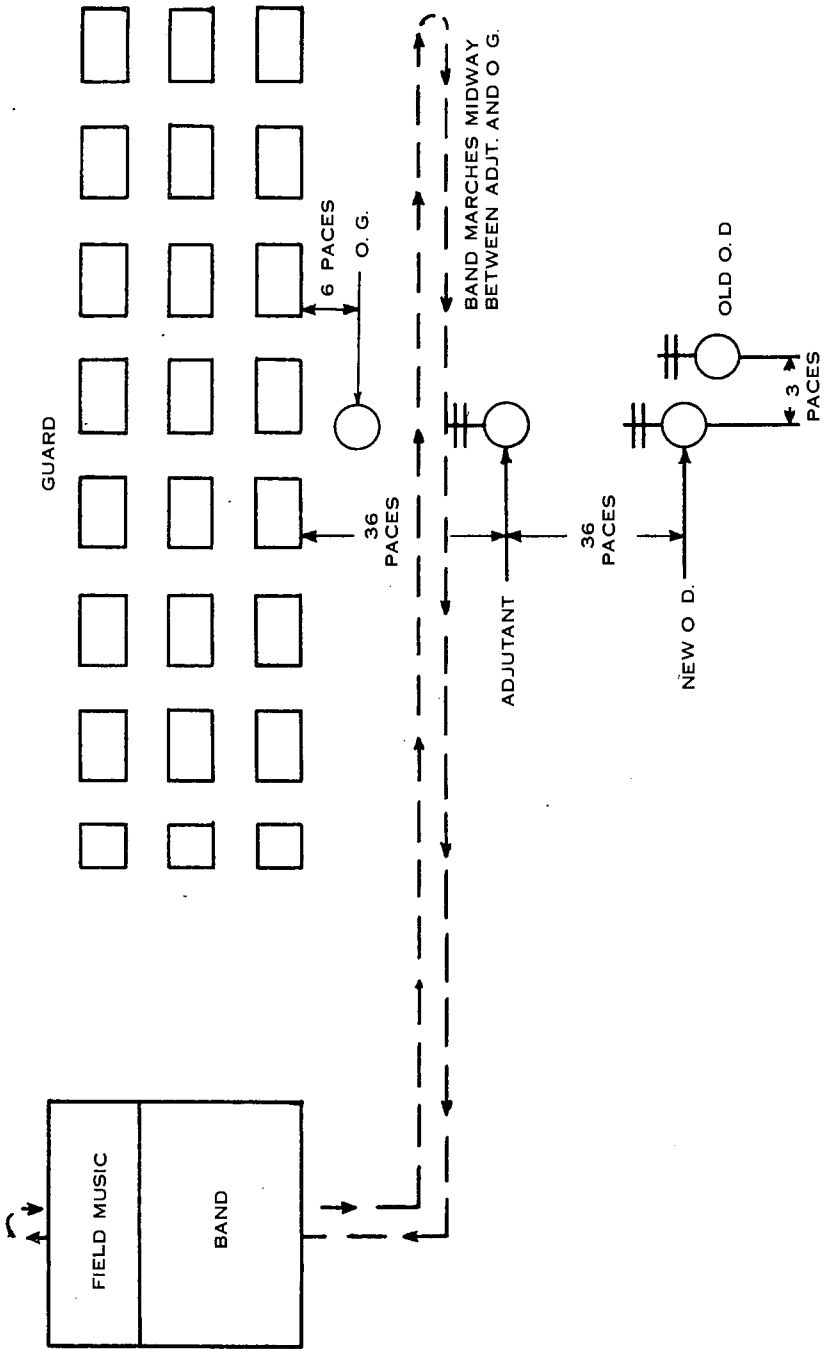
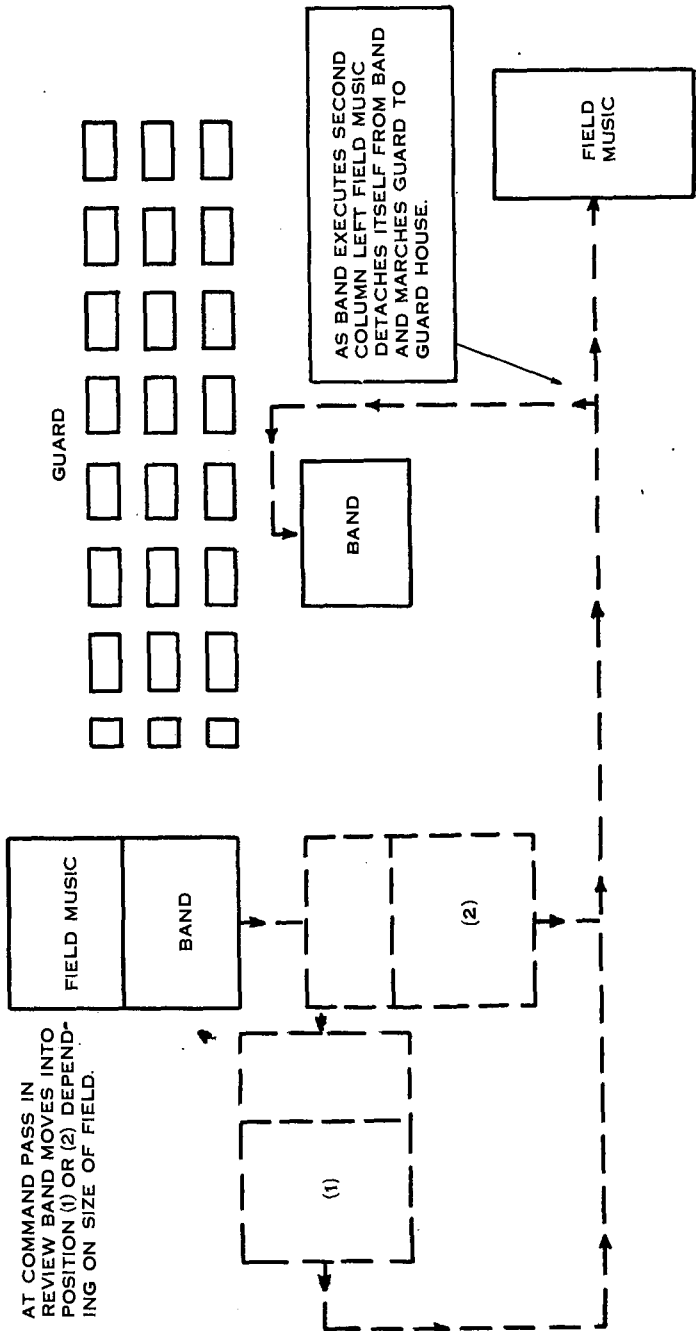


FIGURE 55. TROOPING THE LINE AT SOUND OFF DURING FORMAL GUARD MOUNT.



NEW AND OLD O. D.

FIGURE 56. PASSING IN REVIEW DURING FORMAL GUARD MOUNT.

1. On the command PASS IN REVIEW the band changes direction as prescribed in paragraph 123a(26) and (27). (See fig. 56.)

m. The band being at a halt, the drum major facing to the front will give the baton signal PREPARE TO PLAY.

n. The adjutant, having taken his post 3 paces to the left and on line with the commander of the guard gives the command: 1. RIGHT SHOULDER, 2. ARMS, 3. FORWARD, 4. MARCH.

o. On the command MARCH the drum major gives the baton signal to COMMENCE PLAYING and marching.

p. The band marches past the reviewing officer, saluting according to the principles of a review.

q. After passing the reviewing officer the band makes three left turns and comes to a halt in front of the reviewing officer. (See fig. 56.) It continues to play until the guard is some distance past the reviewing officer when the drum major faces the band and gives the baton signal to CEASE PLAYING. The band is then marched to its quarters without music.

r. If field music is marching with the band, it will detach itself from the band when the band makes its first left turn after passing the reviewing officer (fig. 56) continuing the march in front of the guard following the prescribed route to the guardhouse. The field music will start playing when the band ceases playing in front of the reviewing officer. (See f above.)

s. The field music will remain at the guardhouse until the ceremonies of relieving the old guard are completed. After the field music detaches itself from the band the enlisted man designated as sergeant bugler will be in full charge of the field music.

## Section VI. RELIGIOUS CEREMONIES

**136. GENERAL.** The value of the band as an aid to the chaplain in conducting divine services in the field cannot be overestimated. Orders of service for Protestant, Catholic, and Jewish services are outlined in "Song and Service Book for Ship and Field" and in the "Army and Navy Hymnal" both published by the War Department. The new "Army Chapel Hymns," compiled under the direction of the Chief of Chaplains, is arranged for military band with added string parts and is invaluable to the band leader. These publications are available for issue to authorized Army bands by the Quartermaster Corps and should form a part of every Army band library. The band leader should confer with the chaplain to determine the type of music and the number of selections desired for the service concerned.

## Section VII. NATIONAL ANTHEM

137. GENERAL. a. The composition consisting of the words and music known as "The Star-Spangled Banner" is designated as the national anthem of the United States of America. (See act 3 Mar 1931 (46 stat. 1508; 36 U. S. C. 170).)

b. Provisions in this manual or in orders issued under the authority of the War Department requiring the playing of the national anthem at any time or place will be taken to mean "The Star-Spangled Banner" to the exclusion of other tunes or musical compositions popularly known as national airs.

c. When played by an Army band, the national anthem will be played through with the repetition of such parts as are required to make both words and music complete.

d. On occasions calling for the playing of the national anthem of any country when a band is not available the field music will play "To the Color."

e. On all occasions, when the national anthem of a foreign country is played by an Army band, it will be immediately followed by the playing of "The Star-Spangled Banner." When a group of national anthems of foreign countries are played, (such as during a Pan-American celebration) "The Star-Spangled Banner" will be played after the conclusion of the last foreign anthem.

f. The playing of the national anthem of any country as part of a medley is prohibited. This prohibition will include the composition known as "To the Color," it being tantamount to a national anthem under the provisions of d above.

## CHAPTER 5

### THE CONCERT BAND

---

#### Section I. PREPARATION

**138. GENERAL.** It is in its public appearances and concerts that the band proves its primary value as a factor in morale building. Every public appearance of the band should be marked by an outstanding exhibition of military discipline, showmanship, and musical performance. The principal importance of the band in concert is to provide good musical entertainment for its audience and to present programs that will exert some definite influence toward the mental relaxation, inspiration, and development of esprit de corps of the listeners.

**139. PURPOSE OF PERFORMANCE.** In the selection of music it will be necessary to bear in mind the type and size of the audience for which the band will play. The length of the program should also be considered. Weary field troops will not wish to hear as heavy or as long a program as might be played for a soldier audience in a camp or in a theater, on a well equipped stage and under more ideal conditions. The selections to be played must be left to the discretion of the band leader, who must give serious consideration to working out an entertaining and well-balanced program.

**140. AUDIENCE PARTICIPATION.** The importance of audience participation must not be overlooked. For evening performances the lyrics to popular and old time favorites can be flashed upon a portable screen by the use of song slides and projector, or the lyrics can be mimeographed and distributed to the audience. The latter method is not as satisfactory as the first because it transfers the listeners' attention from the stage to the printed page.

**141. REHEARSING THE PROGRAM.** When the program to be played is technically more difficult, it is advisable to schedule extra sectional rehearsals under section leaders. This method will prove a valuable time saver. (See pars. 27 to 55, incl.) In rehearsing concert music, great stress must be placed on the observance of dynamics, intonation, rhythm, tone quality, attack,



release, and phrasing. Band procedures as outlined in paragraphs 27 to 55, inclusive, will be found to be most helpful.

**142. OUTDOOR PERFORMANCES.** If the band is to play outdoors, the acoustical properties of the place of performance must be taken into consideration. The band leader may find it necessary to change the seating arrangement of the players and employ the use of a public address system. A band which has been accustomed to rehearsing indoors should be rehearsed sufficiently outdoors prior to an outdoor engagement to allow the players to become accustomed to the difference in acoustics.

**143. MANNER OF PRESENTATION.** Showmanship, smoothness in presentation, snap, and precision go a long way toward obtaining enthusiastic reception from audiences of all types and sizes. The band leader must be constantly alert to present the band at its best. The degree of disciplinary training given will be apparent in the posture of the men, the position of instruments when playing and during rests, and in general concert conduct.

## Section II. PROGRAM BUILDING

**144. SELECTION OF MUSIC.** a. Careful program planning will go a long way towards insuring the musical success of a performance. The program must have cohesion and must not be a mere sequence of numbers selected at random. The following factors must not be neglected:

(1) The selection of numbers which suit the instrumentation of the band and the proficiency of the players.

(2) The building of programs that stimulate and maintain the interest of soldier audiences.

b. Selection of a program which is not commensurate with the capabilities of the players reflects upon the judgment of the band leader. If a selected program is too difficult for the players, a ragged performance will result. From time to time it is desirable to select numbers which will allow the more proficient musicians of the band to display their skill in important solo passages. This will be of interest to the audience and have a stimulating effect on the players, many of whom will be ambitious enough to work for similar opportunities.

**145. MUSIC COMMEMORATING SPECIAL EVENTS.** To achieve the greatest possible effect on the audience, consideration of the mood of the different selections on the program is of paramount importance. In a program commemorating any special event, the mood of the chosen selections should conform to the nature

of the occasion. In any ordinary concert, a balance between the light and the serious should be maintained. In addition, the band leader should be constantly aware of the importance of variety in program building. He should be quick to utilize the abilities of his men as soloists, for solo works offer a great deal of variety on band programs. In addition, the band leader should be on the alert for new tunes and the popular pieces from musical shows for these selections are especially enjoyed by audiences.

**146. MUSIC IN HOSPITALS.** Special care must be exercised in the choice of music for hospital programs. While music of a light, cheerful type appears to have a distinctly beneficial effect upon reconditioning and convalescence, violent, enervating jazz is definitely harmful to mending minds and bodies.

**147. PROGRAMS.** Printed or mimeographed programs containing notes on the selections presented will be of help to the audience. If no printed programs can be made available, the names of the selections should be announced in informal fashion in a clear and audible voice.

### Section III. MECHANICS OF PRODUCTION

**148. GENERAL.** While the success of a band performance mainly depends on the ability and efficiency of the band leader and upon the quality of technical training given bandsmen according to paragraphs 27 to 55, inclusive, only detailed preparation and study of the mechanism of band performances can assure presentation of concerts of professional standards. The first step is the designation of responsible and qualified men for individual phases of actual presentation.

**149. PRODUCTION MANAGER.** The production manager is responsible for the smooth operation of the entire program. He is also to see that outer clothing, instrument cases, and other equipment is deposited in a designated location away from the band. Cases, overcoats, or other articles around the chairs of the players spoil the general appearance and should be avoided when possible.

**150. SPECIAL EQUIPMENT.** Sufficient music stands, chairs, and platforms must be arranged in advance. If possible, the band should be seated on a platform in order to avoid loss of a part of the volume of sound. Music clips should be instantly available to each player for all outdoor programs. When a public address system is being used, a trained technician should be on hand to supervise the handling of the microphones. Sufficient rehearsal

with the microphone before the concert is necessary to prevent unexpected and disagreeable distortion of sound.

**151. LIGHTS.** It is important that one individual be given the responsibility of handling the lighting system when the concert is given at night. When the program requires the turning on and off of the band and audience lights during the performance, a cue sheet should be prepared and the sequences rehearsed thoroughly prior to the hour of presentation.

**152. LIBRARIAN.** If necessary, one man may assist the regular librarian in the proper arrangement of the music.

**153. PUBLICITY. a.** All possible publicity should be distributed to all personnel concerned in form of posters, pictures, newspaper articles, and any form of broadcasting available. Hand bills may be effective in some cases.

**b.** When printed or mimeographed programs are practicable, the responsibility for gathering necessary information and the arrangement of an attractive lay-out of the program should be assigned to one man.

**154. USHERS.** When directed audience seating is involved, personnel from outside the band should be obtained and instructed as to the proper seating of special guests or filling certain sections first. When a large area is occupied by a comparatively small audience, it is preferable to seat the latter in a compact group whenever possible.

**155. TRANSPORTATION.** The orderly transportation of men and instruments, especially if the site of the concert is some distance from the band quarters, is essential. Permanent distribution of details incident to the loading and unloading of properties saves time and avoids confusion.

**156. TIMING.** It is very important that the entire program be carefully timed. Many otherwise excellent presentations result in failure when unnecessary waits or lapses between numbers break the thread of audience attention. Any necessary movement of personnel and equipment during the performance must be kept at an absolute minimum.

## CHAPTER 6

### ORCHESTRAS AND SMALL GROUPS

---

#### Section I. THE DANCE ORCHESTRA

**157. DANCE ORCHESTRA.** a. **General.** The military band must be able to provide dance and popular music as well as good concert and military music. The authorized band must have at least one good dance orchestra and should be able, at any time, to divide into several small dance or entertainment units. When used properly and well rehearsed, these various groups can provide a powerful means of entertaining and stimulating the morale of the troops.

b. **Organization.** (1) The band leader should designate a non-commissioned officer as dance orchestra leader. This man should have a combination of leadership, dependability, experience, and definite knowledge of all phases of dance music. He will conduct rehearsals and supervise the making of arrangements. In addition, he will prepare orders for new dance music to be approved by the band leader.

(2) The men playing in the dance orchestra should have had previous experience in reading and playing dance music, particularly in the following positions: 1st trumpet, 1st saxophone, 1st trombone, piano, and drums.

(3) A librarian should be appointed in the orchestra to care for the dance orchestrations. He will see that all music is numbered properly, that torn, frayed, or defaced pages are repaired properly, and that an up-to-date index of the numbers is kept.

(4) An arranger who is experienced in the dance field and who knows the ability of the individual men in the orchestra should be available to write effectively for whatever type of combination desired.

(5) The manager is responsible for the transportation, supply and other details which arise in dance work. In some situations, the dance orchestra leader can do this work in addition to his other duties.

(6) Vocalists and entertainers within the band or the command served may be utilized as soloists or for specialty numbers.

(7) The large dance orchestra is called upon to play dances and entertainments and is often required to play backgrounds for musical shows and revues.

(8) The stock orchestra is so named because it utilizes the commercially published dance orchestrations. The instrumentation used in these arrangements is standard and the stock orchestra can be built from that instrumentation.

(9) The small stock orchestra may also use the published stock orchestrations which are so written to be used, if necessary, with a smaller instrumentation. For example:

1st E flat alto saxophone	1st trombone
2d B flat tenor saxophone	Piano
3d E flat alto saxophone	Bass (string)
1st B flat trumpet	Drums
2d B flat trumpet	

(10) The special dance orchestra uses special arrangements. It may be of varying size, and it depends on the following factors: Instrumentation available, type of orchestra desired, and ability of arranger and players. For example:

1st E flat alto saxophone	4th B flat trumpet
2d E flat alto saxophone	1st trombone
1st B flat tenor saxophone	2d trombone
2d B flat tenor saxophone	3d trombone
Baritone saxophone (E flat)	Piano
1st B flat trumpet	Bass
2d B flat trumpet	Guitar
3d B flat trumpet	Drums

## Section II. SMALL GROUPS

**158. GENERAL.** In remote areas, or in the field where the band is the sole source of music for the troops, entertainment activities described in the following paragraphs have proved to be of great morale-building value. Versatile musicians from the band are supplemented by talent from the other troops in presenting vocal programs, minstrel shows, and variety or "talent" shows.

**159. INSTRUMENTAL ENSEMBLES.** a. Break-down of the band into balanced units provides small groups which may play for soldier singing, for hospital wards, or for general field entertainment. While these groups may play from stock dance arrangements as illustrated in figures 57 and 58, they definitely are not designed to replace the dance orchestra. These combinations will suggest many others which may be equally effective.

b. The combination in figure 57 requires the doubling of four clarinets on saxophone. This use of stock dance parts employs no transposition other than occasional raising or lowering of an octave to fit the practical range of the instrument involved. One bandsman will double on piano or accordion.

Group	Name of Instrument	Part in stock arrangement to be played
I-----	Flute E flat clarinet B flat clarinet E flat alto saxophone French horn Cornet Cornet Trombone Piano	1st violin 3d alto saxophone 2d tenor saxophone 1st alto saxophone 3d alto saxophone 1st trumpet 2d trumpet 1st Trombone Piano
II-----	Alto saxophone French horn Tenor saxophone Tenor saxophone Cornet Cornet Trombone Snare drum String bass	1st alto saxophone 3rd alto saxophone 2d tenor saxophone 4th tenor saxophone 1st trumpet 2d trumpet 1st trombone Drums Bass
III-----	Alto saxophone French horn Tenor saxophone Baritone saxophone Trumpet Trumpet Trombone Baritone Drums B flat bass	1st alto saxophone 3d alto saxophone 2d tenor saxophone Double 1st alto saxophone 1st trumpet 2d trumpet 1st trombone 2d trombone Drums Bass

**FIGURE 57. BAND BREAKDOWN—THREE GROUPS—NO TRANSPOSITION.**

Group	Name of Instrument	Part in stock arrangement to be played
I	Flute E flat clarinet B flat clarinet Alto saxophone Tenor saxophone Tenor saxophone Cornet French horn French horn Piano	Violin I Violin II (transpose) Violin III (transpose) 3d alto saxophone 1st alto saxophone (transpose) 2d tenor saxophone 1st trumpet 3d trumpet (transpose) 1st trumpet (transpose) Piano
II	Alto saxophone Clarinet B flat Trumpet Tenor saxophone Trombone String bass Snare drum	3rd trumpet (transpose) 2d trumpet 1st trumpet 1st trombone (transpose) 2d trombone Bass Drums
III	Alto saxophone French horn Baritone Baritone saxophone Cornet Cornet Trumpet Trombone Trombone Drums BB flat bass	1st alto saxophone 3d alto saxophone 2d tenor saxophone (transpose) 4th tenor saxophone (transpose) 1st trumpet 2d trumpet 3d trumpet 1st trombone 2d trombone Drums Bass

**FIGURE 58. BAND BREAK-DOWN—THREE GROUPS—  
TRANSPOSITIONS NECESSARY.**

c. The combination in figure 58 requires musicians who are sufficiently skilled to transpose readily. Four clarinets double on saxophone. One player doubles on piano or accordion.

d. Trios, quartets, and quintets are effective for indoor playing, mess halls, hospital wards, and chapels. Arrangement and utilization of such small groups will depend upon the skill of bandsmen available.

**160. VOCAL ENSEMBLES.** a. Vocal instruction raises the over-all musicianship of the band. Vocal study improves the individual player's breath control, attack and release, sense of pitch, sight-reading, and phrasing.

b. Vocal numbers of various kinds add interest, color, and variety to band concert programs. Solos, duets, trios, and quartets may be featured as specialties. A chorus may be made up of bandsmen who sing and singers from neighboring troops, under the direction of the band leader or a vocally trained bandsmen. Such a group can afford a great deal of pleasure to participants and listeners.

c. Audience singing from time to time at the band's regular programs is highly desirable. At least two members of the band should be qualified in the making of song slides of current favorites for projection on a screen. The band plays introduction and accompanies the singing.

d. Trained song leaders in each company or similar unit may foster organizational glee clubs and choruses. The band leader should advise and train these song leaders if requested to do so and should encourage the organizing of any of the groups mentioned above.

**161. SOLDIER SHOWS.** Too great a stress cannot be given to the participation of bandsmen in soldier shows. All references and texts on this subject listed in current training programs should be on hand and available to all bandsmen.

**162. CONTESTS AND COMPETITIONS.** Contests and competitions among enlisted men should be encouraged. There are always a great number of individuals eager and willing to compete in amateur shows and quizzes of all types. By coordinating these activities with the responsible recreation officer they may be presented at such time as the maximum attendance of the command is guaranteed. It has been found that a short, lively band, or orchestra concert with some of the activities mentioned above included in the program, presented immediately prior to the evening movie has proved to be extremely popular.



# CHAPTER 7

## THE BAND LIBRARY

---

### Section I. GENERAL

**163. VALUE OF INDIVIDUAL PARTS.** One part lost from a band arrangement destroys the usefulness of the entire number for the organization. Strict accountability for numbers taken from the library for full band use or for individual practice is imperative. The procedures described below insure an accurate record of all music on hand. All music must be kept in the best possible condition at all times. Torn pages should be repaired immediately. The procedures of filing and cataloging music as outlined in this chapter are optional and should be adapted for use if no other systematic filing system has been established.

**164. SELECTION OF LIBRARIAN.** The bandsman selected as librarian will set up and keep appropriate library records and files. Other members of the band may be appointed to assist him; for example, a member of a salon ensemble may handle the music used by it. Other members of the band should be required to draw and return all music through the librarian.

### Section II. PROCUREMENT OF MUSIC

**165. MUSIC CATALOGS.** Music catalogs should be arranged alphabetically by name of publishers and reference copies arranged alphabetically by type of composition.

**166. TYPE OF SETS TO BE ORDERED.** Publishing houses offer smaller arrangements containing all the standard instruments and larger sets containing full instrumentation including such parts as alto clarinet, bass clarinet, 2d oboe, 2d flute, tympani, etc. Generally, purchase of larger sets will be more economical than buying small sets plus additional parts. Orders must be kept on file so that they may be compared with shipments received.

**167. CHECKING OF INCOMING SHIPMENTS OF MUSIC.** Items received must be compared with tallies and packing slips, and parts in each set must be counted. Tallies must be kept on file as a complete record of expenditure of appropriated music funds.

### Section III. CATALOGING AND FILING

**168. CATALOGING OF MUSIC.** For each composition three catalog cards are made out, identical in content but different in color. Set No. 1 is arranged alphabetically by title of composition, set No. 2 is arranged alphabetically by name of composer, and set No. 3 is arranged by classification (see par. 169) or numerically by classification number if numbering system is used. (See par. 170.) Each loose sheet of music should be stamped so that it can be identified immediately as belonging to the unit.

**169. CLASSIFICATION OF MUSIC.** The following classification is suggested :

Functions.	Waltzes.
Overtures.	Patriotic music.
Rhapsodies.	Popular selections.
Suites.	Solos, duets, trios with band accompaniment.
Selections from operettas.	Band collections.
Selections from operas.	Sacred.
Symphonic music.	Miscellaneous.
Marches.	
Concert marches.	

**170. NUMBERING SYSTEM.** A numbering system may be set up with definite classification numbers for each established class of music, for instance No. 1 for overtures, No. 2 for suites, and No. 3 for selections from light operas and so on. Within each class use serial numbers to designate the compositions in that class. For example, assign the number 1-1 to the first overture received, the number 1-2 to the second overture received, the number 2-3 to the third suite received, etc.

**171. ARRANGEMENT OF PARTS WITHIN EACH SET.** Arrange all parts in each set in a standard order of instruments which must be definitely established and must be adhered to at all times. Assign part numbers to parts, following this standard order. For example, give the first part the number 1, the second the number 2 and so on. If the library has more than one set of a composition use No. 101 for the first part in the first set, No. 201 for the first part in the second set, and so on. Each sheet of music will, therefore, show three numbers which may be written on it or stamped on it with a numbering machine. These numbers should always appear in the same relative position on each sheet, for instance, classification and serial number in the upper right hand corner and part number in the upper left hand corner.

**172. FILING.** Music should be filed consistently, preferably by classification. If a numbering system is used, music should be filed numerically by classification number and serial number. Each composition should be kept in a manila folder which should show the name, composer, class, classification number, if any, and the total number of parts. Steel cabinets, legal size, afford best protection for music.

#### **Section IV. PROCEDURE OF HANDLING MUSIC IN REHEARSAL**

**173. NUMBERED MEASURES.** Number measures in all parts to facilitate rehearsing. Sometimes it is advisable to number every measure, but usually it will be sufficient to number every fourth or eighth bar.

**174. MUSIC FOLDERS.** Line up folders, preferably on folder racks, in the standard order of instruments. Folders should be strong, should have inside pockets to prevent music from falling out, and should be marked clearly with the names of the instruments. Place in folders the parts of compositions to be used. The librarian will make such substitutions of parts as the band leader may direct. Before rehearsals and concerts a last-minute check should be made to insure that all parts are distributed correctly.

**175. COLLECTION OF MUSIC.** As soon as music is no longer used it should be collected and accounted for. If numbering system is used, parts should be put back in numerical order. Missing numbers indicate missing parts.

**176. INDIVIDUAL ISSUE AND ISSUE CARDS.** All members of the band receive march folios which are filled by the librarian with the desired collection of marches and/or standard band books containing collections of marches, songs, or other pieces to be used in the field. Instructional methods and other music or books may be issued upon request. Issue cards are used to record all music temporarily given to members of the band or other authorized personnel. If the numbering system is used only numbers need be entered on cards which eliminates many mistakes and takes less time. The issue cards should be signed by borrowers and should be kept in a file, arranged alphabetically by name of borrower.

#### **Section V. DANCE ORCHESTRA LIBRARY**

**177. LIBRARIAN.** a. The dance library is best handled by a member of the dance orchestra and supervised by the dance orchestra

leader and the band librarian. The following system is suggested: Each tune to be used is assigned a number which is written on each part of that tune. Folders are made up for each instrument in the dance band which are filled with the respective parts of all tunes. These parts are arranged and should at all times be kept in numerical order. This enables the dance band leader to announce tunes to be played on jobs by simply calling out the applicable numbers.

b. The librarian should devise usable systems for accounting for music used in the phases of the band's work, such as small groups, vocal music, etc. Thoroughness and simplicity always produce best results.

## CHAPTER 8

### GENERAL CARE OF INSTRUMENTS

---

#### Section I. GENERAL

**178. RESPONSIBILITY OF PERSONNEL.** The band leader will encourage the musicians under his charge to take the utmost pride in the appearance of the instruments. Each member of the band will assume responsibility for keeping his instrument clean and in the highest peak of playing condition. No one will be permitted to use or handle another person's instrument unless permission is granted by the band leader or by the person to whom the instrument is issued. Instruments will be kept in cases at all times when not in use. Before each instrument is put in its case it will be wiped off and swabbed out thoroughly.

#### Section II. WOODWINDS

**179. SWABBING OF BORE.** a. The use of a wire rod with swabbing material attached to one end should be avoided in swabbing out instruments made of wood. Such swabs will scratch and mar the bore. The player should use a piece of chamois or lint-free cloth attached to a piece of string long enough to extend a few inches beyond the length of the longest section of the instrument. A small weight should be attached to the opposite end of the string. The end of the string with the weight on it is dropped through the section of the instrument and the cloth then drawn through the bore.

b. For swabbing out the flute or piccolo, the player should use the slotted cleaning rod which comes with each case. He should obtain a long piece of lint-free cloth about 2 inches wide and 1½ feet long. This cloth is inserted in the slot at the top of the rod and drawn over the tip and wound around in such manner as to cover the entire rod. This cloth-covered rod is then inserted in the end of the section to be swabbed and drawn through. In event that a cleaning rod of this nature is missing, the same type of swab used by the clarinet player can be used.

c. For swabbing out the oboe, a turkey or pheasant feather (preferably a tail feather) long enough to go through the longest section of the instrument should be used. The feather is inserted

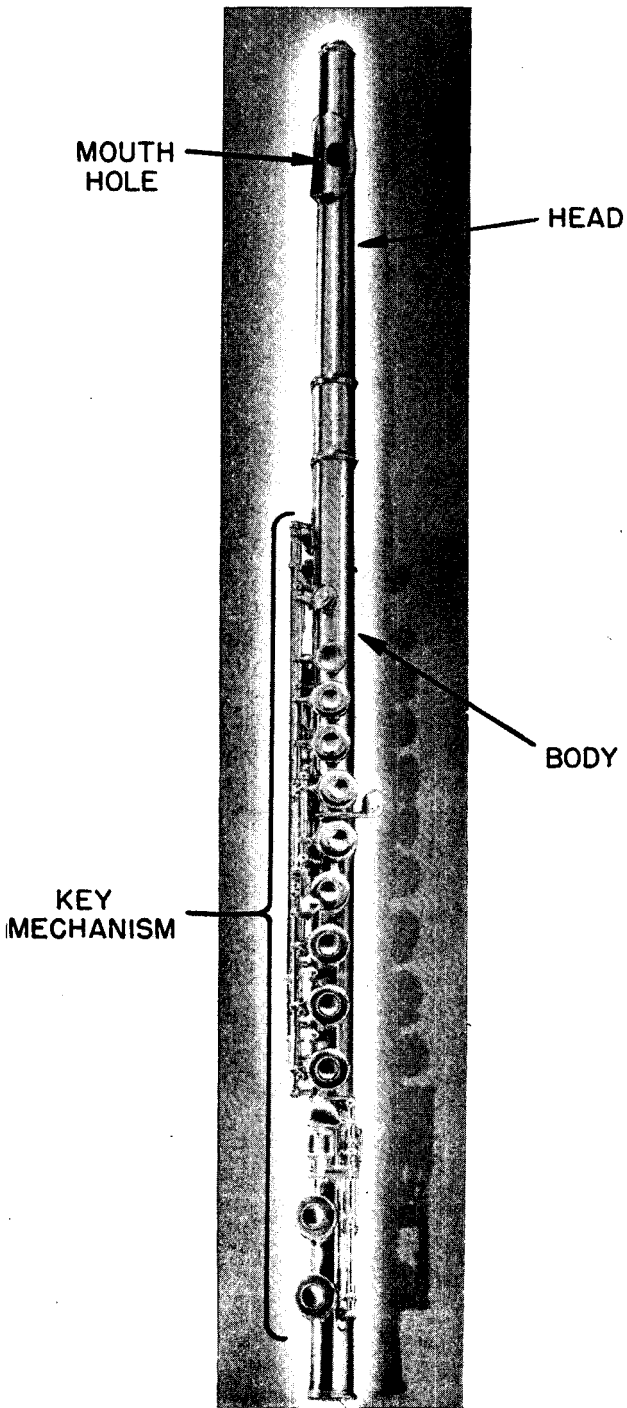


FIGURE 59. FLUTE.

KEY  
MECHANISM



BELL

FIGURE 60. OBOE.

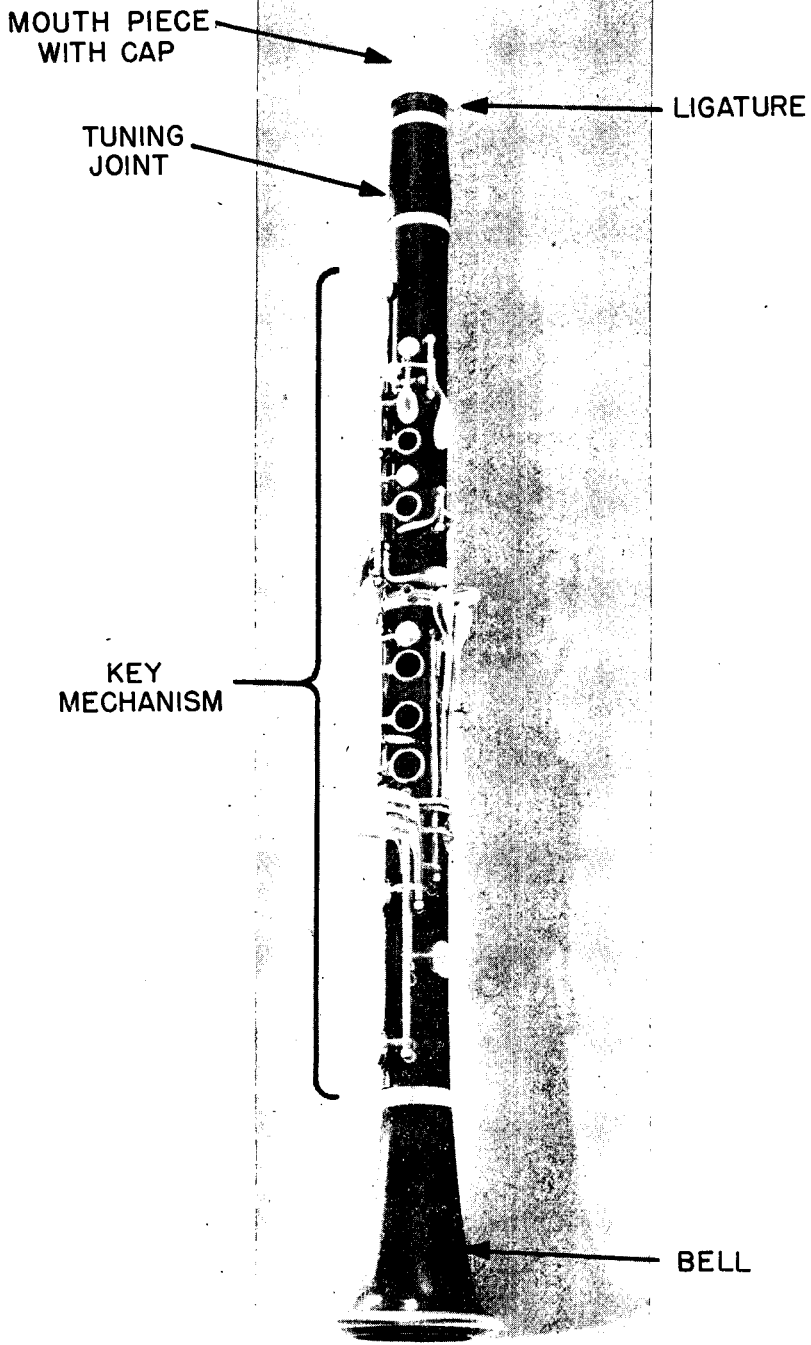


FIGURE 61. CLARINET.



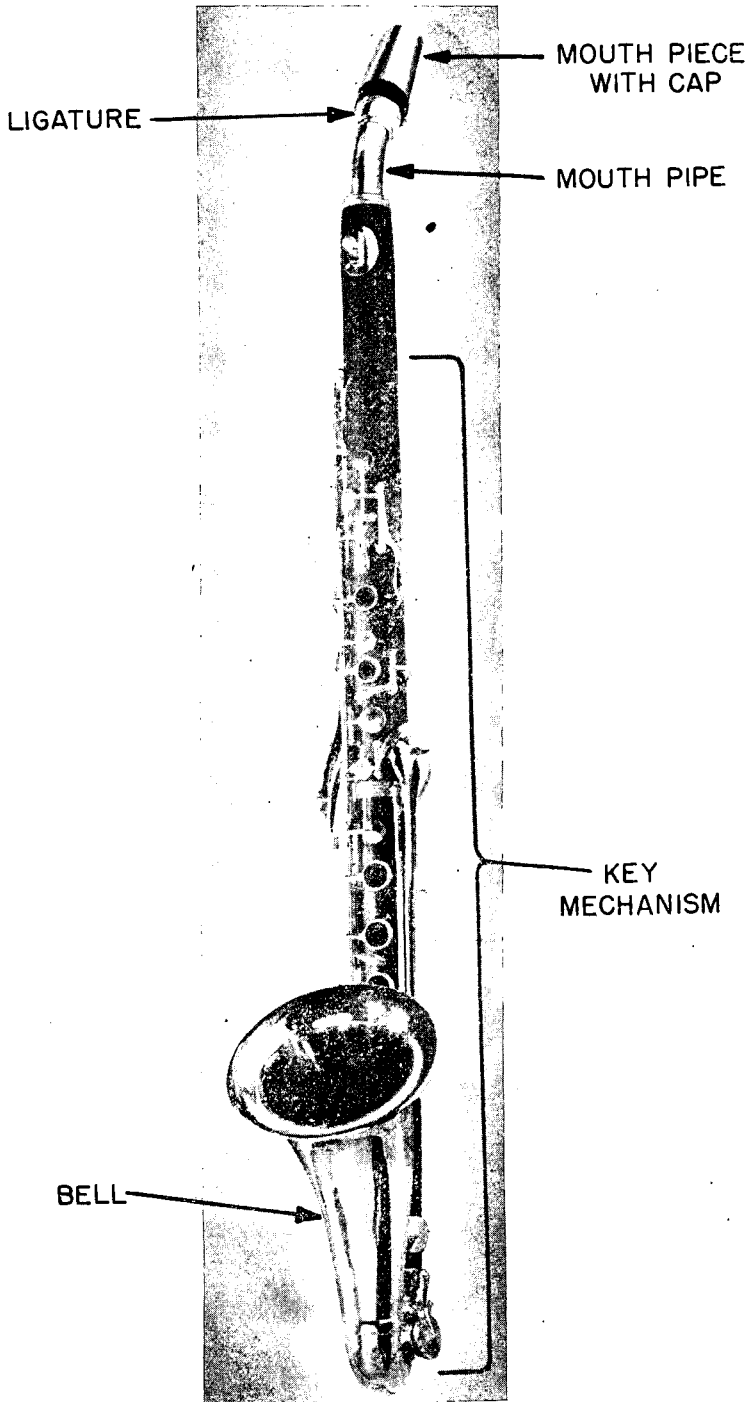


FIGURE 62. ALTO CLARINET.

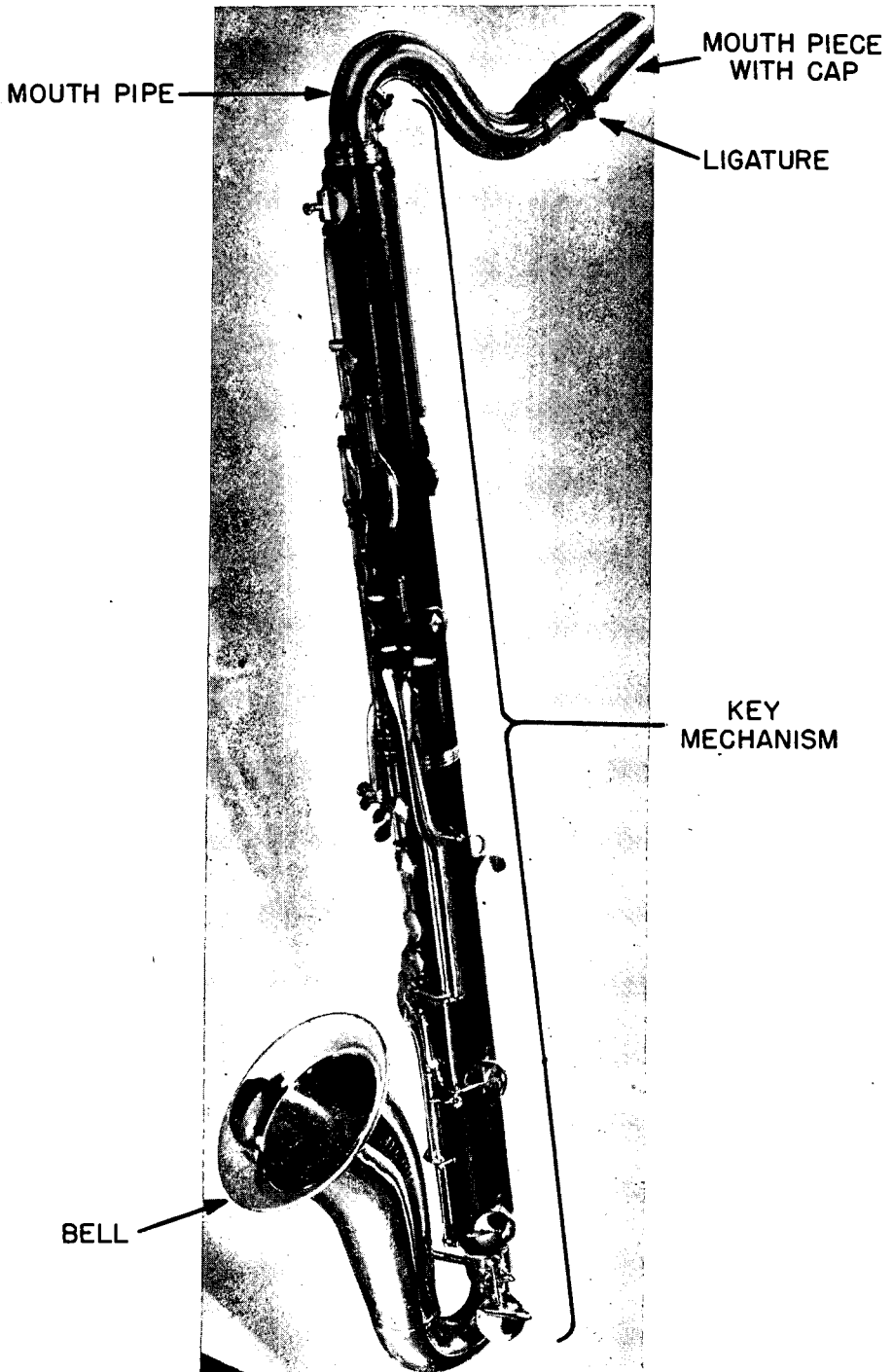


FIGURE 63. BASS CLARINET.

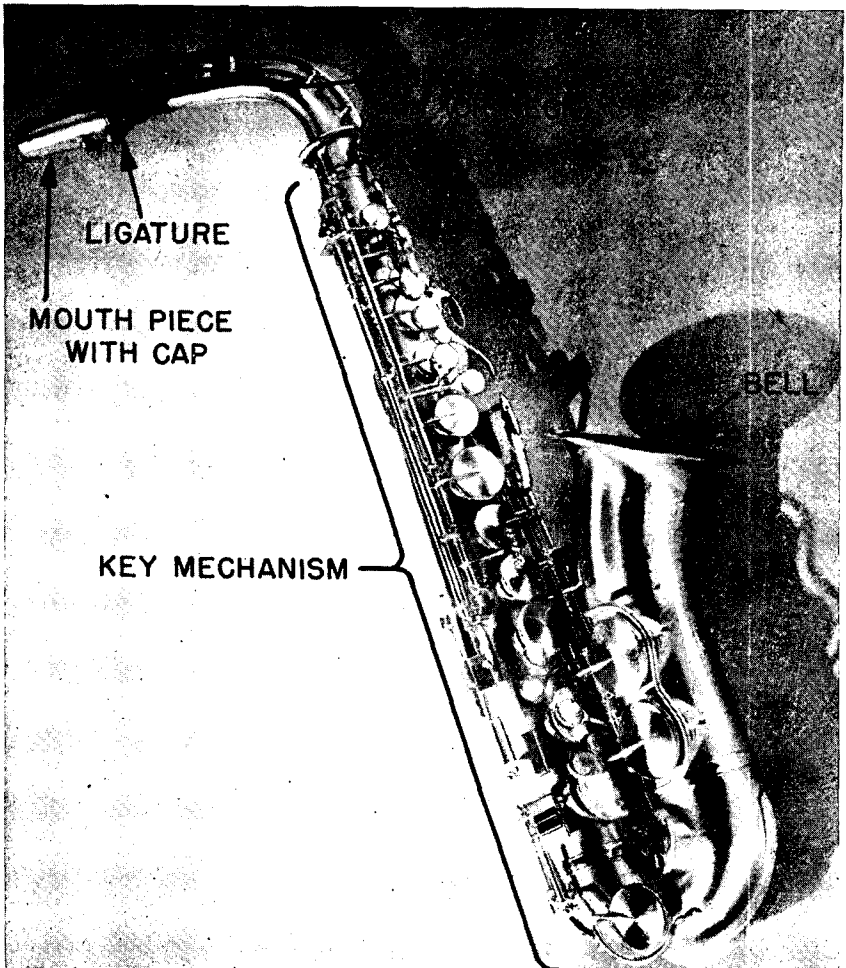


FIGURE 64. E<sub>b</sub> ALTO SAXOPHONE.

in the longer end of the section to be cleaned, twisted a few times, then withdrawn.

d. For the saxophone, a swab similar to the one used for the clarinet should be used in the neckpiece. A long, round wooden handle with swabbing material or lint-free cloth attached to one end should be used to clean the long section. The swabbing out of the saxophone is not as necessary after each session of playing as a wooden instrument. However, it should be done at least once a week in order to prevent moisture from collecting on the pads and causing rapid rotting.

e. For the bassoon, a swab similar to the one used for the clarinet, with the addition of a larger piece of chamois or lint-free

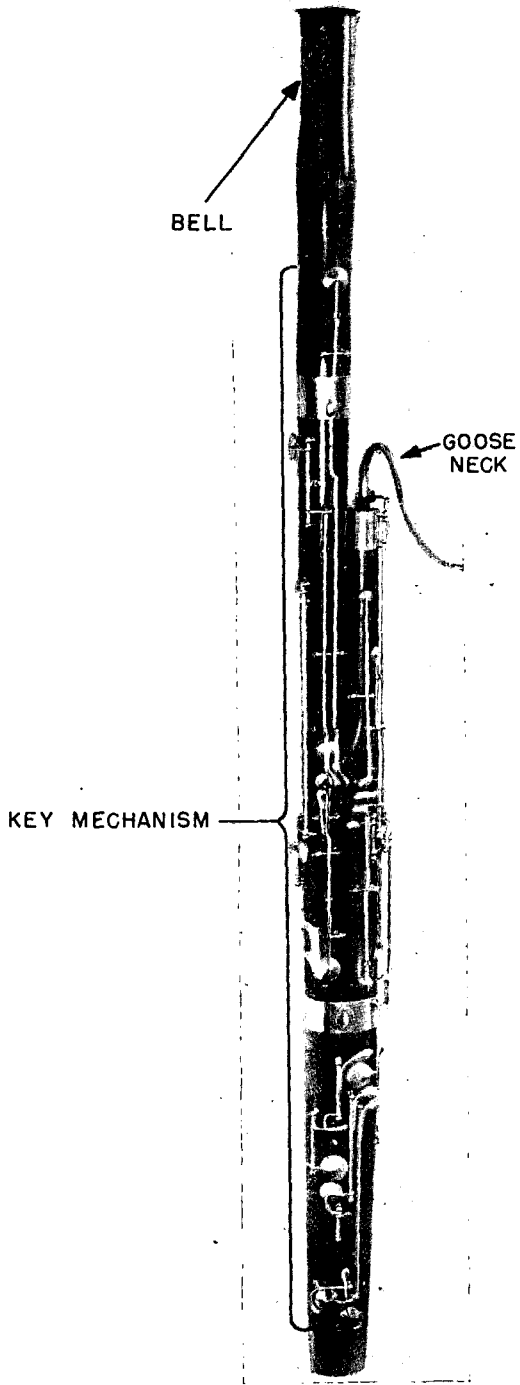


FIGURE 65. BASSOON.

cloth, should be used on the tenor joint just below the crook. A long, round wooden handle with swabbing material attached to one end should be used in the bass joint. To swab the butt joint, tip the joint so that the accumulated moisture will run out of one of the openings, then swab it out with the same rod as used on the bass joint.

**180. CLEANING KEY MECHANISM.** To clean the key mechanism and surfaces of a woodwind instrument, a soft piece of flannel, some jeweler's rouge, and a soft bristle brush should be used. The posts, pivot screw points, rods, and springs should be brushed gently with the soft bristled brush until all particles of dust and lint are removed. Then jeweler's rouge is applied to the key surfaces by putting some of the rouge on the piece of flannel and rubbing it gently on the keys. After the rouge is applied, rub each key surface with a clean portion of the cloth until it is clean and polished. No rouge should be allowed to touch the pads.

**181. EXPOSURE TO EXTREME VARIATION OF TEMPERATURE.** The sudden exposure of any wood instrument to cold, heat, or extreme variations of temperature should be avoided, as this is the chief cause of cracking. A woodwind instrument, if not used, will seldom crack if properly stored and properly handled when again put into service. The cause of cracking in most cases is that, when playing, the instrument is warm and moist on the inside. This causes it to swell on the inside, but the outside being dry and cool resists this expansion, thus creating two forces opposite to each other. If the expanding force is sufficiently strong the instrument will crack.

**182. OILING.** a. A thin film of oil should be applied at regular intervals to the inner wall or bore of instruments made of wood, with the exception of the bassoon. The time for application of this oil varies with the age and use to which each instrument is subjected. A new instrument should be oiled once or twice a week for the first 4 weeks, then oiled once a month for the next 8 or 10 months. After that time, twice a year is sufficient. Oiling helps preserve the wood and prevents cracking. Linseed or olive oil is considered best for this purpose. To apply, use a piece of cloth which has been soaked in oil and wring out as dry as possible. Attach to this cloth a piece of strong cord, at the other end of which is a smooth weight. Drop the weighted end of the cord through the section to be oiled and then draw the cloth through. Care should be taken that no oil gets on the pads during this procedure. A thin piece of cork or paper should be placed under

each pad before the cloth is drawn through the section.

b. The mechanism of all woodwind instruments needs oiling at various points in order to keep the action of the instrument in good working order. Following are the points to be oiled:

- (1) Points of contact between a key and post.
- (2) Juxtaposition of two key hinges.
- (3) All pivot screw points.
- (4) All needle and flat springs.

c. Caution should be taken not to put too much oil on each of these points, as too great a quantity tends to collect lint and dirt. The oil should be applied by dipping a toothpick or piece of fine wire into the oil and, after letting the excess oil drip off, applying the end of the toothpick or wire to the point of application.

**183. JOINT RINGS.** If the joint rings become loose, they can be forced on with a little paper under them. This treatment also applies to the ring on the bell joint.

**184. GREASING OF JOINTS.** Joints or tenons which have cork covering must be greased with vaseline, cork grease, tallow, or paraffine. This greasing must be done at regular intervals so that the tenon can slip in and out of the tenon receiver without any undue pressure or strain put on the joint. The same procedure applies to bassoons which have thread instead of cork wound around the tenon.

**185. CLEANING OF MOUTHPIECES.** Mouthpieces and reeds should be kept clean and sanitary at all times. Mouthpieces should be washed out frequently in lukewarm water and mild soap. Reeds should be wiped off carefully after each session of playing.

**186. UNDUE STRAIN ON KEY MECHANISM.** Woodwind instruments should never be laid down on the key mechanism. This tends to bend the keys and rods and allows the moisture in the instrument to run into the tone holes and ruins the pads.

### Section III. BRASS INSTRUMENTS

**187. JAMMING OF MOUTHPIECE.** Jamming the mouthpiece into the mouthpipe often causes split tubing. All valve slides, tuning slides, and other accessories required for adjustment of pitch should be kept in working order by using grease which is issued for this purpose.

**188. REMOVING FINGER BUTTONS, VALVE CAPS, ETC.** The use of chisels, pliers, or other metal instruments in removing finger

buttons and valve caps, top or bottom, should be avoided. When valve caps stick, due to corrosion or other causes not produced by accident, the instrument should be placed in a position where hot water can run over the cap as this treatment applied for a few seconds will cause the cap to loosen, and removal can then easily be accomplished. If this does not give desired results, tap the valve cap or button with a small rawhide or wooden mallet. A few taps should be all that are necessary.

**189. STORING.** When an instrument is to be laid away for any length of time, valve caps should be greased and a little oil (No. 2 oil which is issued by the Quartermaster Corps) rubbed on the valves, so that the instrument will be in working order when again called into service.

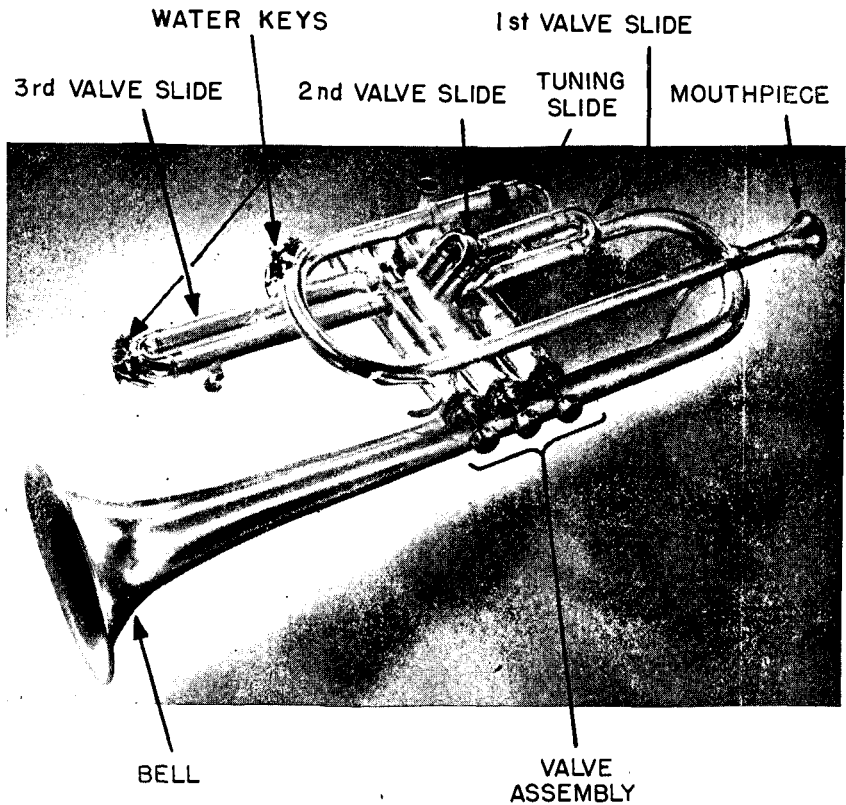


FIGURE 66. B<sub>b</sub> CORNET.

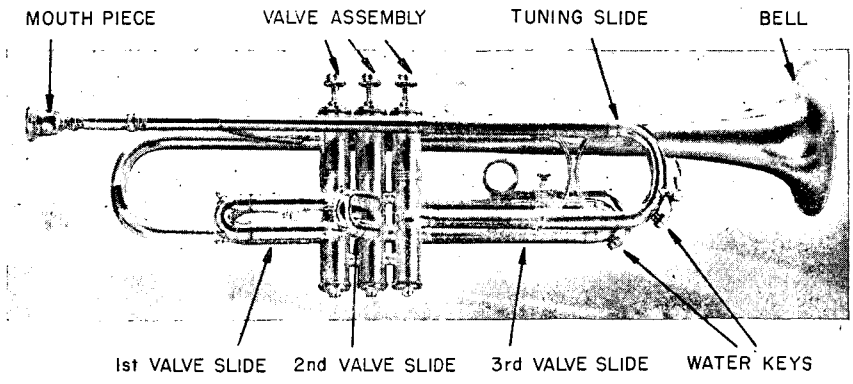


FIGURE 67. B $\flat$  TRUMPET.

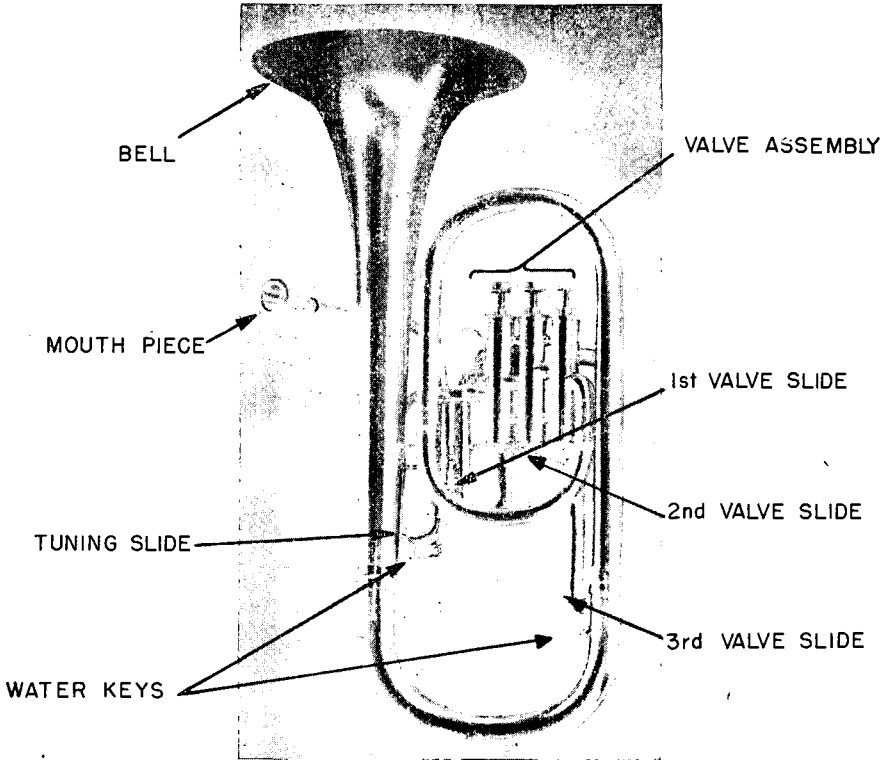


FIGURE 68. E $\flat$  ALTO HORN.



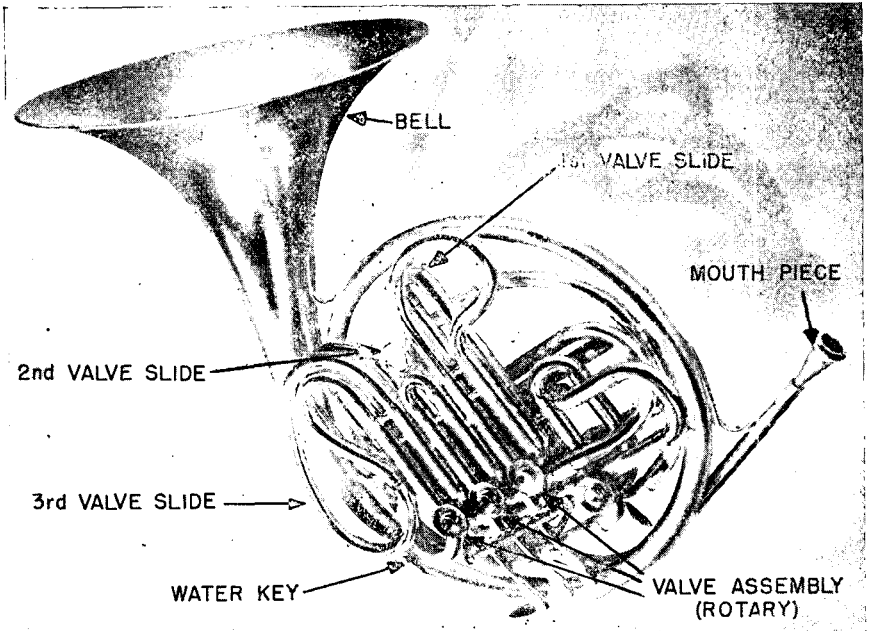


FIGURE 69. FRENCH HORN.

**190. PRESERVATION OF FINISH ON METAL INSTRUMENTS.** Body acids from perspiration plus natural chemical action such as corrosion or rust tend to ruin the finish of metal instruments, both inside and outside. There are several types of finish for brass instruments, therefore, various specific precautions must be taken to preserve these finishes.

**191. CLEANING OF SURFACE.** a. To clean the surface of an instrument with a brass finish, a mild metal polish containing no abrasives should be applied to the entire surface and then strapped with a piece of soft, lint-free cloth.

b. To clean the surface of an instrument with a sand blast finish, a paste made of bicarbonate of soda (baking soda) and water should be applied to the entire surface with a medium bristle tooth brush. The amount of rubbing should be governed by the amount of dirt or tarnish on the section to be cleaned. After the sections are clean, the entire instrument should be washed in clear water and the water marks removed with a piece of soft, lint-free cloth by daubing, not strapping. For a larger instrument such as the tuba, a medium bristled hand brush can be used.

c. To clean the surface of an instrument with a silver plate

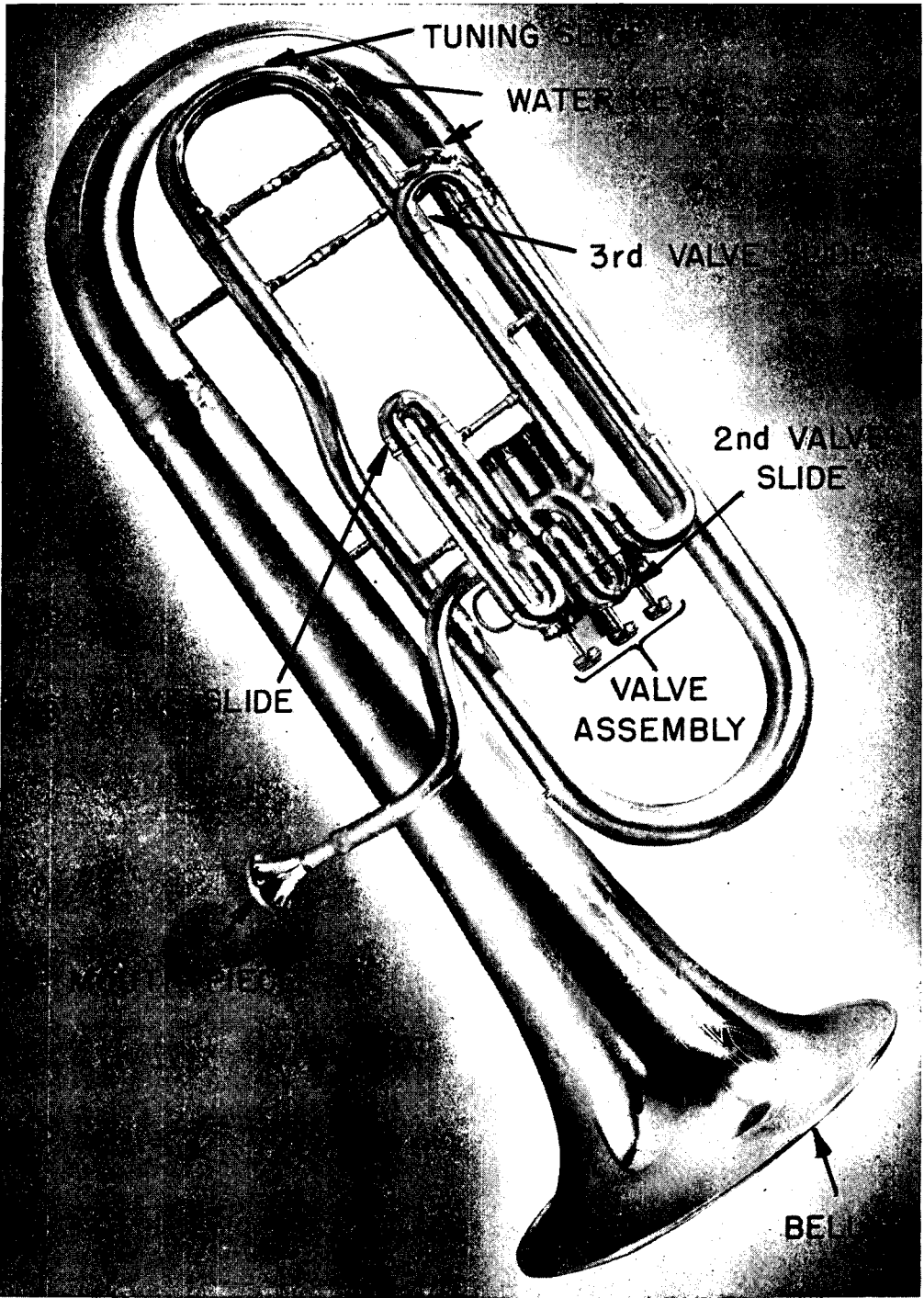


FIGURE 70. BARITONE.

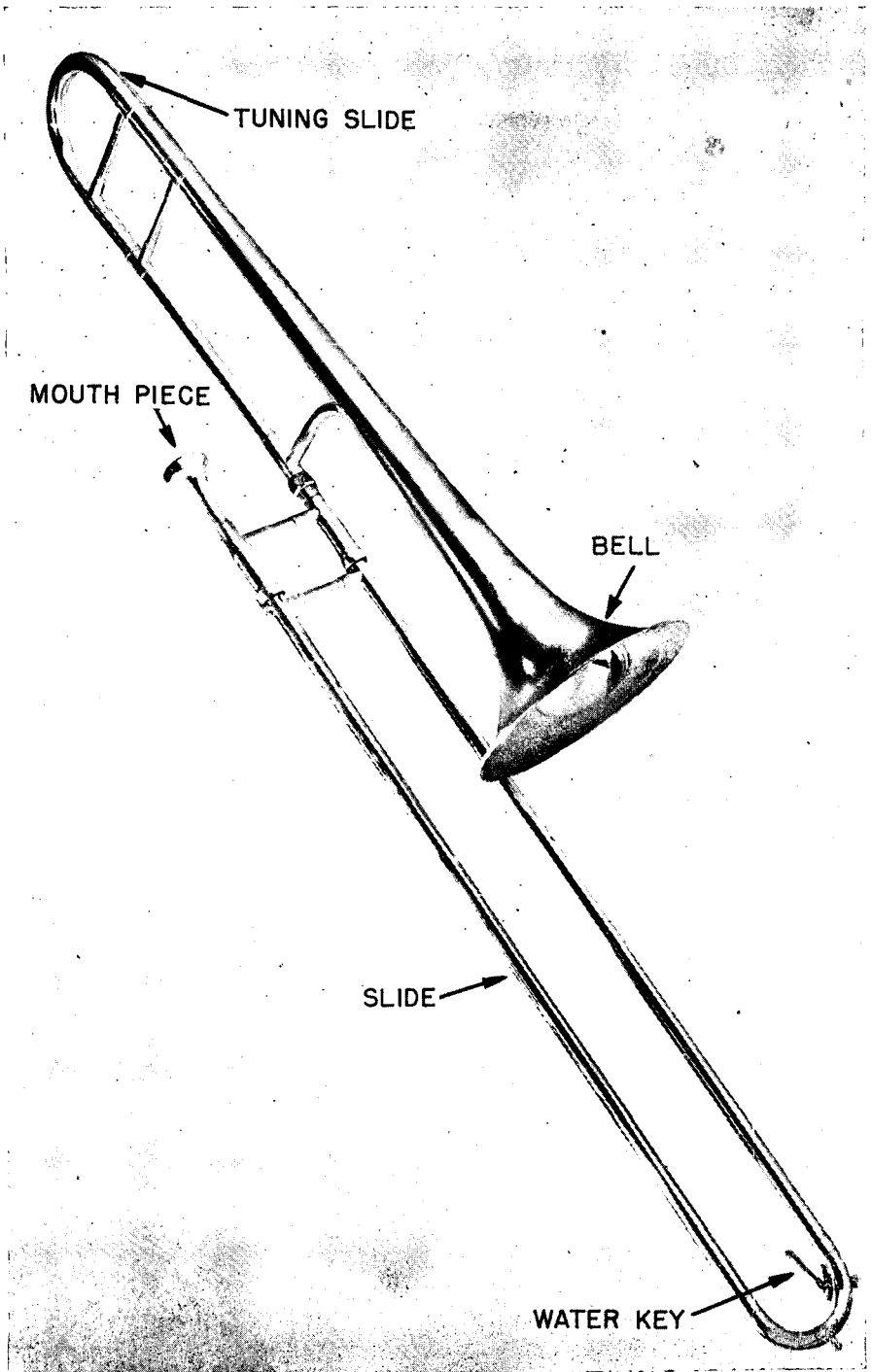


FIGURE 71. TROMBONE.

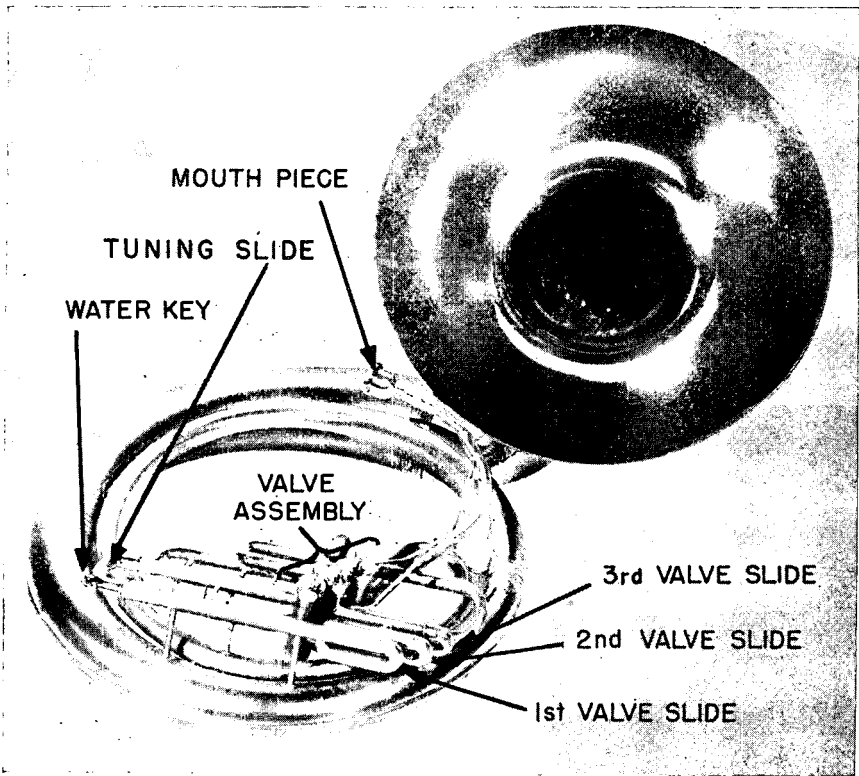


FIGURE 72. SOUSAPHONE.

finish, a mild silver polish should be applied to the entire surface and then strapped with a piece of soft, lint-free cloth.

d. To clean the surface of an instrument with a lacquer finish, a dry or slightly damp cloth only should be rubbed over the surfaces.

e. To clean gold-plated bells, damp, soft, lint-free cloth should be rubbed very gently over the surface.

**192. CLEANING OF BORE.** To clean the inside of brass instruments, a solution of mild soap and warm water should be poured into the bell of the instrument and permitted to run through the entire length of tubing. As the solution passes through the valve section of the instrument, the valves should be moved up and down several times to permit the solution to pass through the valve slides. After the solution has loosened the corrosion and dirt in the instrument, it should be rinsed in cold, clear water by fitting a nozzle to the mouthpiece and permitting the water to flow through at a moderate pressure.

**193. CLEANING OF MOUTHPIECE.** The mouthpieces of brass instruments should be cleaned and removed from the instrument after every session of playing. A piece of string with a soft cloth attached should be run through the mouthpiece to remove the moisture and dirt particles which accumulate. It should then be secured in its proper place in the case or in a small pouch to prevent the rim from getting dented or the thinner edge from getting mashed in. A mouthpiece loose in the case may cause serious damage to the instrument.

**194. CLEANING OF VALVES.** a. To clean the valve and tuning slides of the trumpet, cornet, horn, baritone, and tuba, the slides should be removed and all dirt, rust, or corrosion removed with a piece of soft, lint-free cloth which has been dipped in gasoline. The slides should not be buffed or strapped as this tends to wear down the metal and eventually will cause the slides to fit too loosely. After the slides are clean, apply vaseline or a good grade of cork grease sparingly over the entire valve sleeve. This prevents corrosion and wear and allows the slides to work freely.

b. To clean the piston valves of a brass instrument, remove each valve and bottom valve cap and wash them in a solution of mild, pure soap and water, then rinse in clear water. Care should be taken while handling the valves not to drop or strike them against hard objects as the metal is very easily dented. After rinsing, they should be laid out on a piece of lint-free cloth in the proper order for replacing. The valve casing should be swabbed out thoroughly before the valves are replaced. This should be done by wrapping a piece of cheese cloth around a swab rod, being careful not to mar the walls of the casing. The valves should then be dipped in cold, clear water and each put back in its properly numbered position. The utmost precautions should be taken while cleaning valves inasmuch as they are the most delicate part of the brass instrument.

c. The cleaning of rotary valves is considered a repair procedure to be done by a qualified repair man if possible. (See par. 212.) Rotary valves are hand made and not interchangeable; therefore, the utmost care should be taken when handling this section of an instrument.

**195. CLEANING OF TROMBONE SLIDE.** Trombone slides are very delicate and require careful handling. Great care must be exercised to prevent springing or denting. Each slide must be cleaned separately. After cleaning inner slide, it should be placed on a clean cloth or clean surface. Wash out slides with a mild soap and water. For outer slide, take a piece of weighted cord about

5 feet long with a piece of lint-free cloth about 5 inches wide and 3 feet long. Run this through the slides until cloth comes out clean. To clean inner slide, use weighted cord and cloth or cloth and cleaning rod. Gasoline, benzine, or a mild polish (avoid all types of abrasive) can be used to clean the outside surfaces of the inner slide. Slight discoloration is not harmful as long as slides work freely. Slides should not be used while dry as this causes minute scratches on the slide surfaces. Many preparations are used for slide lubrication, but good trombone oil is considered best. Oil prevents scratches and also guards against corrosion caused by body acids.

#### Section IV. PERCUSSION INSTRUMENTS

196. GENERAL. In the care of percussions special attention should be given the heads and snares. There is no set rule for correct tensioning of heads. However, heads should be tightened

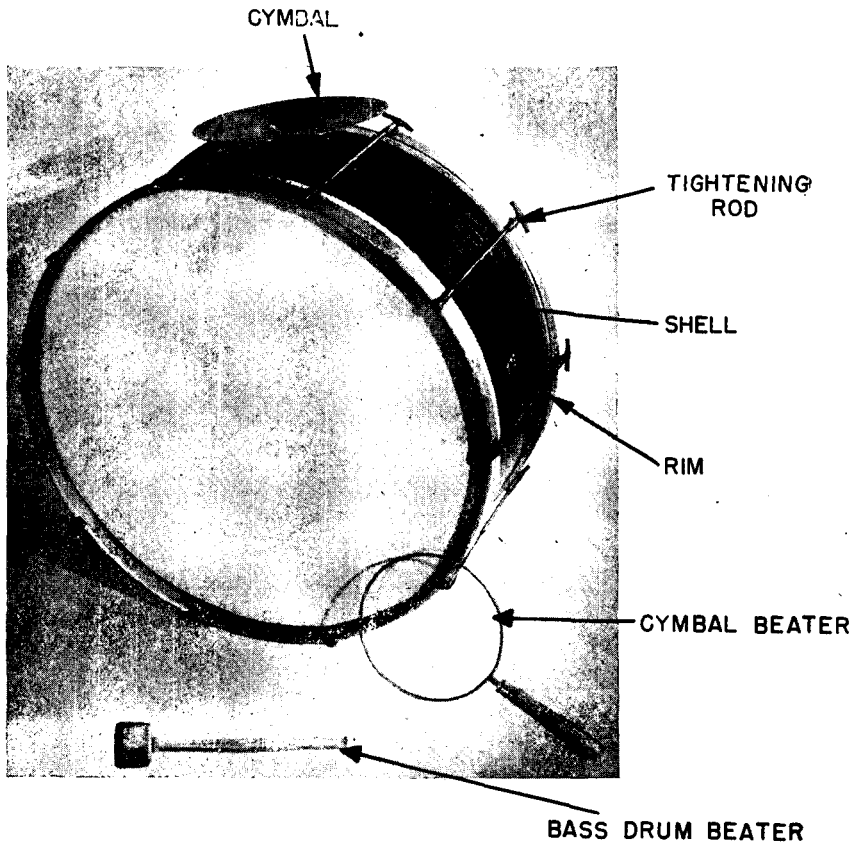


FIGURE 73. DRUM, BASS, WITH CYMBAL.

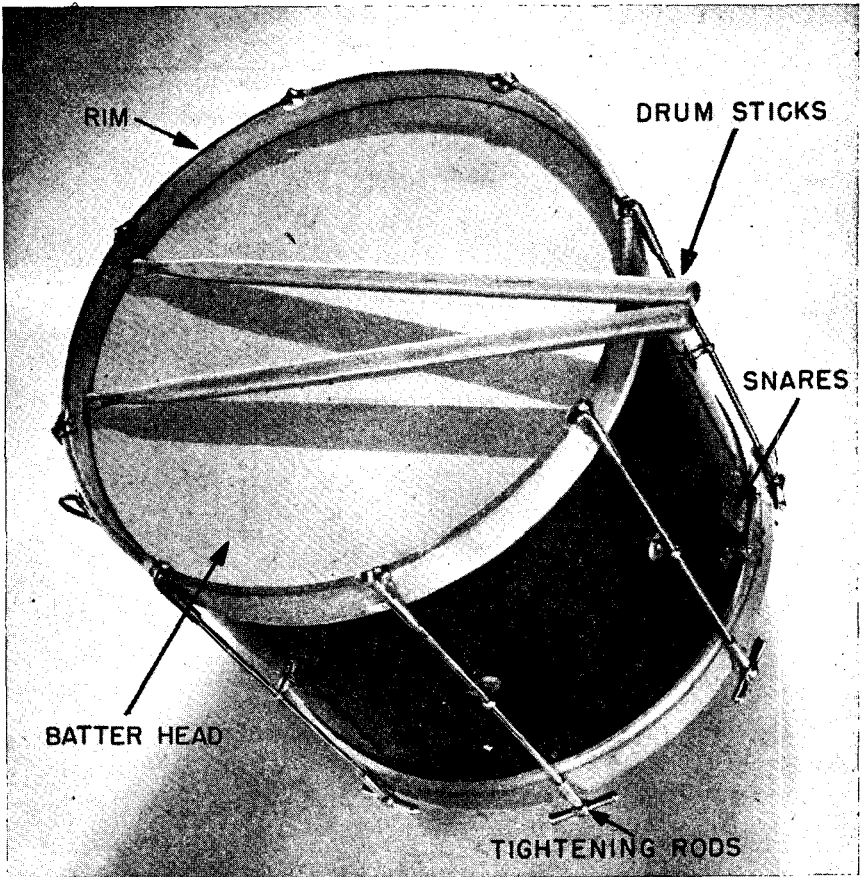


FIGURE 74. DRUM, SNARE, FIELD.

alternatively from opposite sides of the rim, never in a clockwise manner. The crispness of head determines the correct tension. Leave tension normal except when weather is rainy or damp. In such weather release tension when through playing to allow heads to resume normal tension. Keep percussions covered while stored away, especially tympanies, xylophones, marimbas, etc. All hardware should be kept dry, screw and strainer bolts and all moving parts should be kept oiled and clean. Gut snares should be kept taut while not in use as they are affected by moisture and must be protected from becoming entangled or stretching unevenly.

197. **CYMBALS.** Cymbals require the same care that is exercised with any other musical instrument. They should never be allowed to drop and should be stored where there is no danger of their being jammed under or between heavy objects.

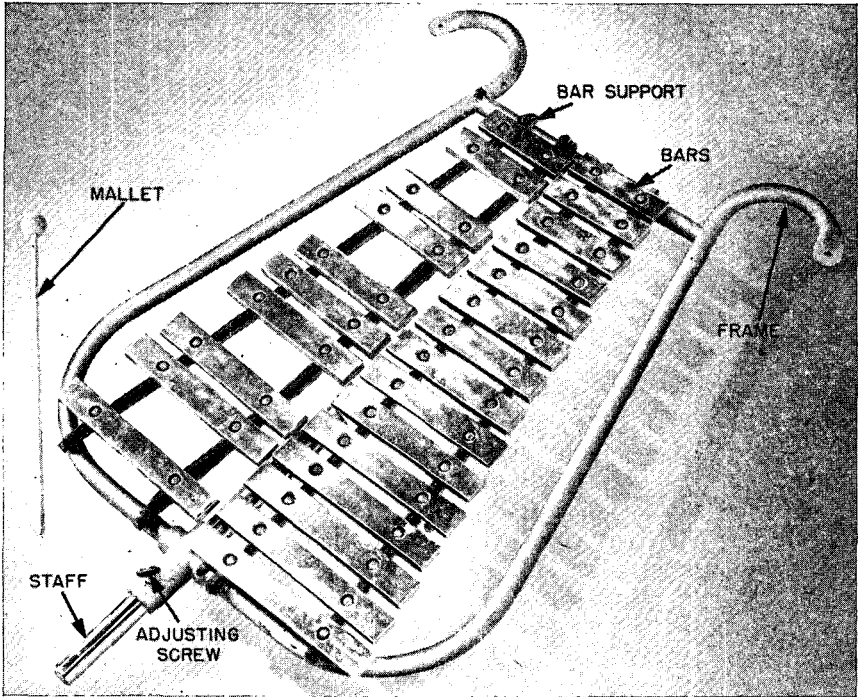


FIGURE 75. BELL, LYRA.



## Section V. STRINGED INSTRUMENTS

**198. STORING.** The stringed instruments should not be kept where sudden changes in temperature take place. In very hot and damp weather for example, the glued joints have a tendency to open up. One should not tamper with the varnish of an instrument. The proper way of removing rosin and dust is to use a very soft cloth and lightly wipe away the foreign elements. It is always advisable to use the finest strings available. The entire tone quality of the instrument is affected by the quality of strings used.

**199. EXCESS ROSIN.** Excess rosin on the strings can be removed by wiping across the strings with a small cloth moistened in alcohol.

**200. TENSION OF BOW.** For playing, the bow hair should not be tightened beyond the point where the bow loses its "spring" or resilience. Constant check should be made to insure that the bow be rehaired as often as an appreciable number of the bow hairs have broken. It is especially advised that the bow be loosened each time after playing. To grasp the bow properly, care should be maintained that the hands do not touch the hair of the bow.

**201. PIANO.** a. The portable piano issued as standard equipment to the band is a delicate musical instrument and must be treated as such. While it is specially reinforced for field use, it must be handled with extreme care and should be moved only when absolutely necessary. The total pull of combined string tension on the lyre structure exceeds 15 tons. Any sharp jar, jolt, or whack causes the pegs to slip and throws strings out of tune. In moving, it is advisable to place an old mattress between the instrument and both floor and side of the truck to absorb as much shock as possible. A sufficient number of men should be detailed to move or lift the instrument to insure smooth, easy handling. The piano must always be kept upright, never tilted on its back.

b. The piano is extremely sensitive to climatic conditions. Exposure to sudden changes in temperature should be avoided where possible. In a very dry climate the action may become loose and begin to rattle. Drying of the wood sound board allows pegs to slip. A small glass jar of water kept in the bottom of the instrument will help to prevent excessive drying. Where damp or wet atmosphere may cause rusting, sticking of keys, and other damage

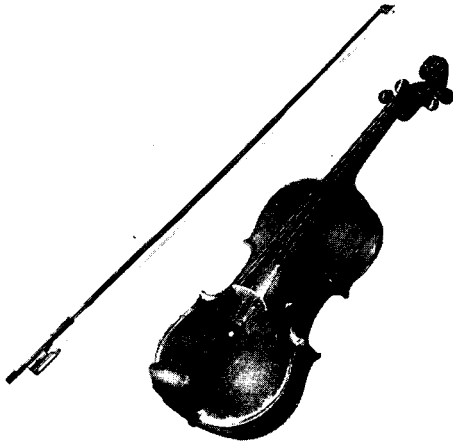


FIGURE 76  
VIOLIN



FIGURE 77  
VIOLA



FIGURE 78. VIOLONCELLO.

to mechanism, a lighted electric bulb may be suspended inside the piano.

c. Tuning of pianos should be done by an experienced piano tuner. When none is available to the band, however, a good musician can considerably improve the intonation of a piano which has become partially out of tune. Using the tuning kit which is issued with each piano, the procedure is as follows: By plucking with a toothpick or sliver of wood, determine the highest pitched string of the three on each note. Using the felt mutes or the muting strip, block out one of the other strings. With the tuning hammer pull the third string up to the pitch of the highest with short, sharp jerks. Adjust until all "beats" (clash of sound waves) are eliminated. Block out the string just tuned with mutes and adjust the remaining string to the first. Finally, check all three for perfect unison.

d. While this method does not produce perfect intonation, it will improve the over-all pitch and put the instrument in more playable condition. The band leader should endeavor to arrange for the training of at least one of his bandsmen in the method of proper piano tuning.



FIGURE 79. BASS VIOL.

## CHAPTER 9

# REPAIR OF MUSICAL INSTRUMENTS

---

### Section I. WOODWINDS

**202. REMOVING STUCK PINS AND SCREWS.** Soak the screws as much as possible with penetrating oil. If they still stick, apply more oil and then apply heat to the part and key hinge, being careful not to burn the instrument. After it cools, heat it again, applying penetrating oil between each heating. While removing the screw, be sure the screw driver has a good firm bite in the head of the screw. Turn the screw driver both to left and right as if tightening and loosening the screw. If the screw is rusted in the hinge and not in the post, it will move back and forth with hinge. By holding the screw firmly and moving the key in the opposite direction from which screw driver is trying to turn the screw, the rust usually breaks loose and frees the screw. On badly rusted-in screws, twist a piece of pipe cleaner material around the hinge where it meets the post, soak it with penetrating oil and let stand over night.

**203. CLARINET AND SAXOPHONE REPADDING.** To replace pads in a clarinet, first remove all bits of old pad from the cups. Select size pad that fits snug in pad cup and is thick enough to keep from body of instrument. If the pad is not thick enough it must be built up with shims of heavy paper. Make certain there is shellac between the pad cup and shim and if more than one shim is used, shellac between shims, and also between pad and shim. Before putting pad in cup, prick either the center of pad or side of pad with a fine pointed needle. This allows the air to escape when heating the pad to seat it. (See figure 80.) Heat the pad cup until the shellac is melted, place pad in cup (and shims if needed) making sure the pad is level with cup, then let cool. Place key on the instrument and apply heat to the pad cup but not enough to let the shellac run. (See fig. 81.) Be careful not to let the flame touch the pad as it will scorch or burn. Apply pressure to the key to form a seat on the tone hole.

**204. RECORKING WOOD JOINTS.** Take off all old cork and glue by scraping, making certain the joint is clean. Cut a strip of cork so the grain will be lengthwise. Cut the strip so the cork

goes around the joint. Cut a bevel on each end, but opposite sides of the cork for a lap joint of around  $\frac{3}{16}$  to  $\frac{1}{4}$  inch. (See fig. 82.) After cutting cork to correct length and width, but before cutting bevel, pound the cork with a rawhide or wood mallet to make it flexible, thus eliminating possibility of cracking. Heat stick shellac evenly around the joint, being careful not to burn the instrument or the shellac. While the shellac is hot, wrap the cork around the joint, making certain there is shellac on the lap joint. Wind twine on evenly around cork to hold it on joint until shellac is cool. If stick shellac and burner are not available, liquid shellac may be used. The same procedure is used except after placing liquid shellac on the joint burn the alcohol out by placing over a flame. A match will produce enough heat to ignite the alcohol, then follow through as if using stick shellac. Trim the cork down to a snug fit with sandpaper and apply joint grease. Do not use stick shellac or a flame on pads as they soften more than rubber. Use liquid shellac and allow to dry 24 hours.

#### 205. RECORKING METAL JOINTS (CLARINET, SAXOPHONE NECKS).

Clean old cork and shellac from neck. Cut a strip of  $\frac{3}{32}$  cork, long enough to go around the neck and as wide as needed. Bevel the ends for a lap joint of a little over  $\frac{1}{4}$  inch. Apply the cork around the neck and tie with twine. (See fig. 83.) If there is not enough shellac on the lap joint too much attention should not be given it as heating will cause it to stick. Either heat a rod and insert in the neck or hold the end of the neck over the flame until the shellac bubbles through the pores of the cork or from the ends. Allow to cool and trim to size with sandpaper.

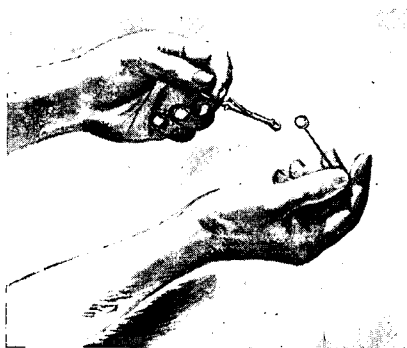


FIGURE 80. PAD IN CUP AND POINTS TO PRICK HOLE.

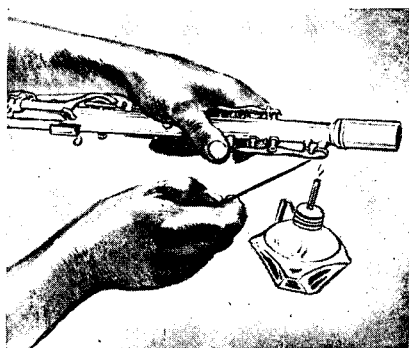


FIGURE 81. SEATING PAD.

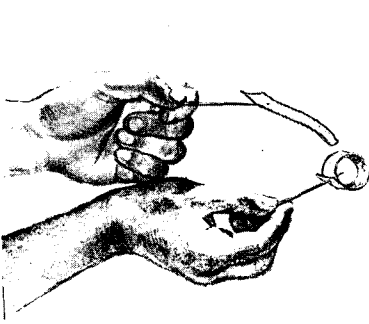


FIGURE 82. CUTTING JOINTS.

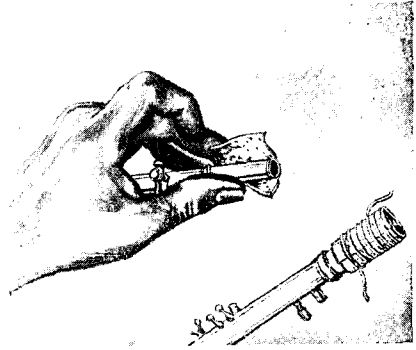


FIGURE 83. CORKING AND TYING JOINTS.

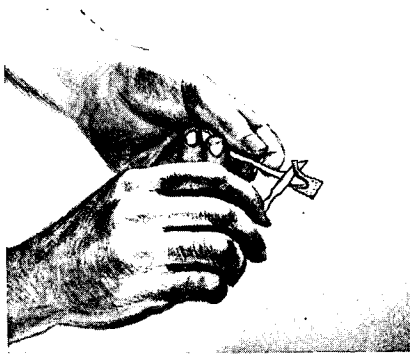


FIGURE 84. TRIMMING CORK.

**206. RECORKING SAXOPHONE NECKS WITH CORK TUBES.** Remove octave key. Clean off old cork and shellac. Ream inside of cork tube with sandpaper or round file to a taper to fit the neck. Cut tube to desired length, and heat small end of neck over flame until it will melt stick shellac when rubbed over it; apply stick shellac over area to be covered by cork tube, let cool then slip cork tube over neck. If loose, wrap twine around tube, and hold small end of neck over flame in such manner that flame will go up into the neck and melt shellac under cork tube. Shellac will be melted enough when tube can be turned easily. Let cool and trim to proper size.

**207. REPADDING FLUTES.** A flute is one of the most difficult instruments to repad, as the pads must never have a deep seat, therefore, they cannot be seated with heat. Possibly, when you remove the old pad from the flute you will find one or more washers or spacers. It is a good idea to save these. Flute pads must be built to the proper height with the use of spacers. If a pad

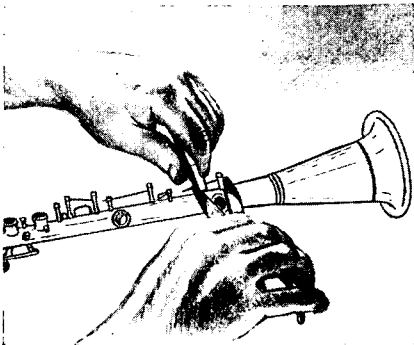
hits in back and gaps in front you must remove either a complete spacer or a one-half or one spacer must be added. The pads must be seated in with just a bit more pressure than the light playing pressure. No part of the pad must touch the tone hold before any other part.

**208. RECORKING KEYS.** Cut a piece of cork of the proper thickness large enough to cover the part to be corked. Scrape off old cork and shellac on the key. Heat key just enough so the shellac will melt but not enough to burn the shellac. Place cork on key and hold firmly until the shellac has cooled. With a sharp knife trim the cork (fig. 84) to fit the key and then finish with fine sandpaper. The cork can be trimmed to fit the curvature of the part of the instrument it touches. Proper thickness of cork is very important on the instrument, not only to silence the noise, but also to give the proper alignment and key clearance.

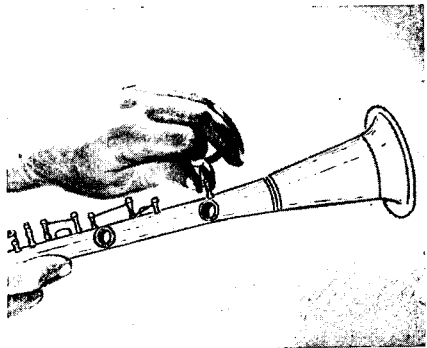
**209. REMOVING SPRINGS.** a. To remove a whole spring, take a pair of pliers in the left hand and place them about  $\frac{3}{16}$  to  $\frac{1}{4}$  inch from the post, take a second pair of pliers in the right hand and grip both the first pair of pliers and the post. Be sure to place the jaw of the pliers in the right hand, above or below the spring hole, on the opposite side of the post, so the spring can back out. (See fig. 85.)

b. When stub is left, place one jaw of pliers on stub and the other above or below the spring hole and squeeze out. (See fig. 86.)

c. When spring breaks flush with the post, remove post if possible or brace post against something to keep from bending post out of line. Using heavy spring as a punch, place the point on the broken part and back out. (See fig. 87.)

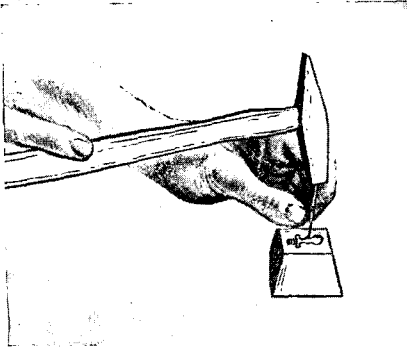


**FIGURE 85. REMOVING WHOLE SPRING.**

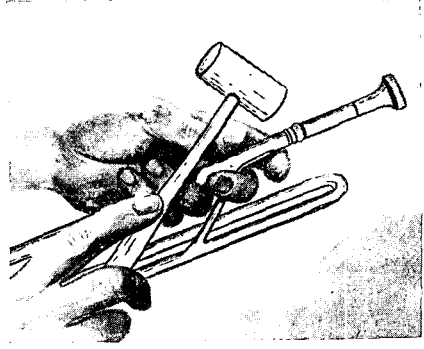


**FIGURE 86. REMOVING STUB.**

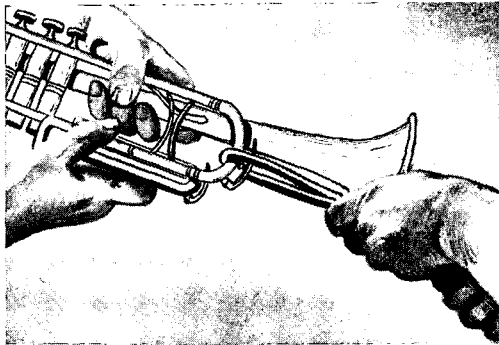




**FIGURE 87. REMOVING FLUSH  
BROKEN SPRING.**



**FIGURE 88. REMOVING STUCK  
MOUTHPIECE.**



**FIGURE 89. REMOVING STUCK SLIDE.**

## Section II. BRASS

**210. REMOVING STUCK MOUTHPIECES.** Hold mouthpiece and mouthpipe in one hand and strike the ferrule with a mallet. (See fig. 88.) Use a sharp but not heavy blow. If the mouthpiece does not loosen, put the ferrule on a block and strike opposite side with mallet, turning the ferrule all the way around so that no spot is flattened. If mouthpiece is too jammed or corroded, apply penetrating oil and let it soak, then apply a bit of heat to mouthpiece, enough so that the mouthpipe is hot to the touch. Repeat process if necessary.

**211. REMOVING STUCK SLIDES.** Loop a rope through the curve of the stuck slide. (See fig 89.) Fasten the free ends to a vise or something solid, or have someone hold the free end. A series of sharp jerks on the horn ordinarily will cause the slide to become loosened. Do not jerk too hard as this will spring the valve casing. At times, slight tappings on the slides with a

mallet helps break the corrosion. Under no circumstances should a tuning slide be struck to loosen it. If slide remains stuck use penetrating oil and heat as in the third operation of removing stuck mouthpieces.

**212. ROTARY VALVES.** The rotary valve is one of the most delicate valves used in the brass family. Rotary valves, unlike piston valves, are not interchangeable as each is handmade for the particular instrument in which it is used. Too much stress cannot be placed upon the care that must be used while working on them. Rotary valves do not have to be taken out and cleaned as often as piston valves. Frequency of cleaning depends on type of playing conditions encountered. In removing valves the following procedure should be observed:

- a. Remove string.
- b. Loosen main screw on top of valve but do not remove entirely.
- c. Remove bottom cap.
- d. With mallet, tap the top main screw to force out valve. (See fig. 90.) One hand should be held under valve at all times to receive the valve.

- e. Keep repeating fourth operation, loosening main screw until valve is removed.

- f. Clean valves thoroughly removing all lint, and make certain caps are free from dirt. In replacing valves, the following procedure should be followed:

- (1) Oil.
- (2) Insert valve.
- (3) Replace bearing cap, and make certain that guide lines are in the right place.
- (4) Tap gently on the bearing cap, first on one side and then on the other. Care must be taken to see that the valve goes in evenly.

- (5) While tapping bearing cap keep rotary valve turning to make sure it is free.

- (6) End play must be of the very slightest degree.

- (7) Replace string and caps.

**213. REPLACING VALVE SPRINGS.** Valve springs are of two types: those placed in the bottom of the casing and those in the upper part of the valve stem. Care should be taken that the coils remain straight and are not bent at any angle. If a spring is too strong the tension can be relieved by the ends being compressed to center of spring using a slight circular motion. A spring should never be cut to relieve tension. If the spring tension is too weak it can be strengthened by taking the ends

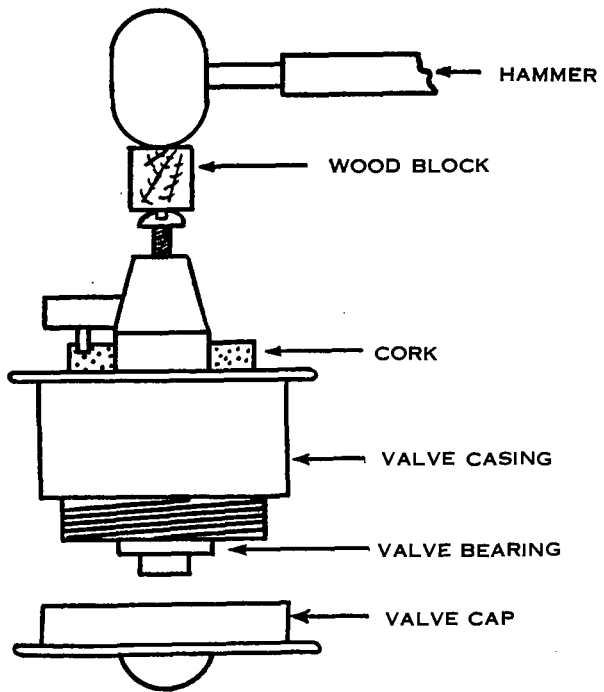


FIGURE 90. REMOVING ROTARY VALVE.

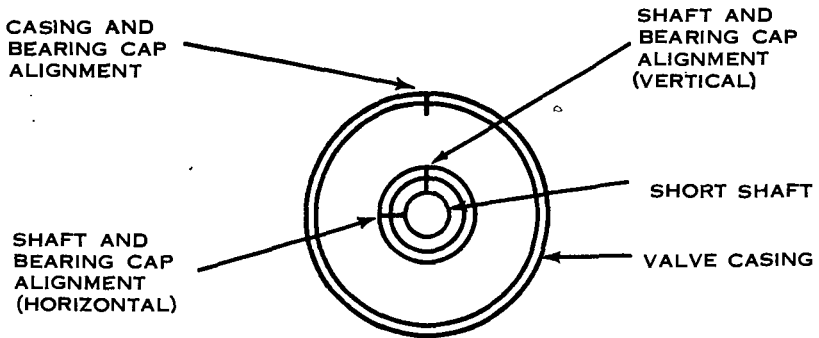


FIGURE 91. REPLACING ROTARY VALVE.

of the spring in both hands and pulling slightly while turning the hands about a quarter turn in opposite directions.

**214. REPLACING WATER KEY CORKS.** Remove the water key and clean out the old cork. Select new cork. Work cork down to

proper size with fine sandpaper to fit the water key cup. Use either stick or liquid shellac to hold the cork in the water key cup. Allow more thickness of cork than is needed. After the key is replaced work cork down to desired thickness by drawing a strip of sandpaper between the cork and the opening.

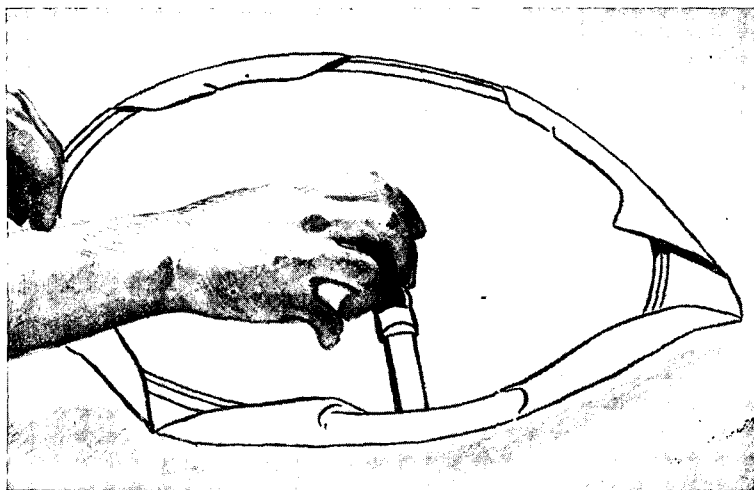
**215. REPLACING WATER KEY SPRINGS.** In replacing water key springs patience must be exercised as the springs do not always fall readily into place. First the coils are mounted over the extending shafts of the key. Some springs are fastened around the posts, other types of springs lie on the tubing. After placing the spring in position on post, the key is held in place with left hand and the screw is inserted with the right hand.

### Section III. PERCUSSION

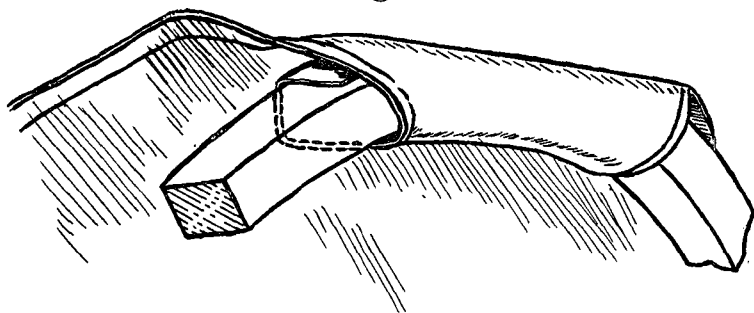
**216. TUCKING DRUM HEADS.** a. In removing a broken drum head, first remove all the rods, then take the counter hoop and flesh hoop from the shell. The broken head should then be cut and removed from the flesh hoop. It is necessary to cut a head three to four inches larger than the hoop diameter of a snare drum and five to six inches larger for a bass drum. The head should then be soaked in clear, lukewarm water until it is soft and pliable. This process takes from fifteen to twenty minutes, depending upon the thickness of the head. The vessel containing the water should be large enough so that the drum head need not be crushed while soaking. After removing from the vessel, shake off all excess water and lay it on a clean, smooth, flat surface with the smooth (outside) side of the head down.

b. The flesh hoop is then placed with the flat side down. Care must be taken to keep the hoop an equal distance from all edges of the head. Begin by tucking one side of the head completely around the hoop, then tuck a spot directly opposite. Then tuck points halfway between those previously tucked. (See fig. 92 ①.) Now begin tucking around the hoop in a clockwise fashion, being sure the head is unwrinkled and is completely wrapped around the hoop. (See fig. 92 ②.) When reaching any of the four spots previously tucked, it may be necessary to loosen the head at this point again to remove any wrinkles which may have developed. Any excess water should be wiped from both sides of the head before placing the hoop back upon the shell of the drum. Then place the counter hoop directly above the flesh hoop and fasten the rods around the shell in the same manner as the procedure done in tucking the head. Each of the rods should then be pulled down the same distance so that the head will dry evenly. About

four turns is recommended. The head should be allowed to dry for at least 24 hours before regular tension is applied to the rods.



①



②

FIGURE 92. TUCKING DRUM HEAD.

#### Section IV. STRINGED INSTRUMENTS

**217. GENERAL.** The following paragraphs on the violin are in general, applicable to all strings. Whenever possible, violin repairing, especially regluing, should be done by an expert repairman. However, minor repairs can be made by the amateur if he will be patient and careful in doing them.

**218. SOUND POST SETTING.** a. When properly placed, the entire end surfaces of the sound post should touch the upper and lower plates of the instrument. The sound post should not fall when the strings are released, even if the violin is moved and turned. If it does fall, it is too short and a new one should be made. When

in place, the sound post should move rather easily; if it is wedged in too tightly, it should be shortened.

b. To set the sound post, a commercial sound post setter should be used if obtainable. The post is placed in the violin through an F-hole with one end of the setter and then pushed into position with the other end. If no sound post setter is available, the post may be put in place by the use of two strings tied around either end of the post with a half-inch knot, as in figure 93. The handle of a tablespoon is very helpful in wedging the sound post with the string method. When the post is in place, the strings can be removed by pulling on either end. However, the violin strings should be tightened first so that the sound post will not again slip out of place.

c. When properly placed, the sound post is under the E-string foot of the bridge, with its front end set even with the back edge of the bridge, as shown in figure 93. Its upright position is vertical. The exact sound post position varies with instrument. If the E and A strings are weak, the post should be moved nearer to the F-hole. If the G and D strings are weak, the post should be moved nearer to the center of the instrument. If the entire instrument is weak the post should be moved closer to the center of the instrument.

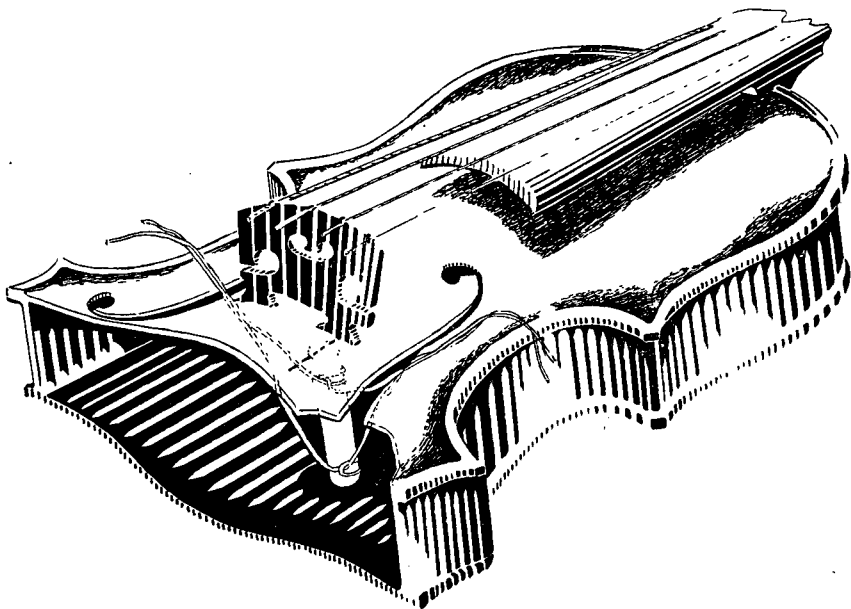
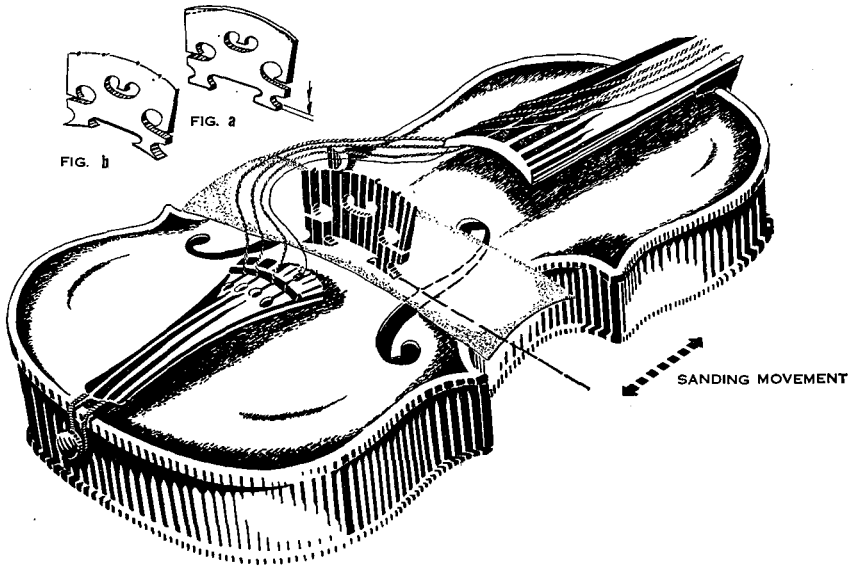


FIGURE 93. SETTING SOUND POST AND RELATIVE POSITION OF BRIDGE AND SOUND POST.

**219. FITTING THE BRIDGE.** If a new bridge is to be fitted (a, fig. 94) it can be trimmed to the approximate shape of b, figure 94, varying to suit the finger board contour of the particular instrument. The feet of the bridge must contact the instrument top on their entire surfaces. To accomplish this the bridge can be placed on top of the instrument over a sheet of sandpaper and moved back and forth until the desired result is obtained. (See fig. 94.) The bridge must remain vertical during this movement.



**FIGURE 94. TRIMMING THE BRIDGE AND SANDING BRIDGE FEET.**

**220. HEIGHT AND POSITION OF BRIDGE.** The height of the bridge should be suited to the individual requirements of the player. If these are not known, a good practice is to have the E string  $\frac{5}{32}$  inch and the G string  $\frac{9}{32}$  inch above the lower end of the finger board. The bridge must be arched so that the A and D strings can be bowed individually without touching any of the other strings. The bridge is in position when its front edge is even with the notches on the F-holes. It should be placed so that the strings are centered over the finger board. The bridge should have slight notches to hold the strings in place. These can be cut with a knife or file. (See b, fig. 94.)

**221. TAIL PIECE GUT.** To fit the tail piece gut, place the gut through the tail piece and measure it in place on the instrument. It is the proper length when the end of the tail piece is about  $\frac{1}{16}$  inch away from the edge of the instrument. The tail piece

and gut are then taken off and with the gut still through the holes on the tail piece, the ends of the gut are burned to make them swell. Pieces of thread may then be wrapped around the edges for additional strength. If no gut is available, wire may be used with good effect.

☆ U. S. GOVERNMENT PRINTING OFFICE: 1946—697216